

INNOVATING SAFETY

Ihr Kontakt in Deutschland:

ALFRED KONRAD VEITH GmbH & Co. KG

Verrenberger Weg 1 • D-74613 Öhringen

Tel.: +49 (0)7941 698 115 • Fax: +49 (0)7941 698 189

Email: info@veith-kg.de • Web: www.veith-kg.de

Cilindri molla ad azoto
Nitrogen gas cylinders
Stickstoffgasdruckfedern
Cylindres-ressort à l'azote
Cilindros resorte de nitrógeno
Cilindros com mola ao azoto

2018



WHAT'S NEW?



Changes and additions to previous catalogs

Product reference	Change description	Page
NG series	New series	28
Easy manifold	Upgrade section	211
EV Easy manifold	New model	214
39TE002A / 39TE012A	New model	218
39TM01A...	New connection	243
36TSM9/160...	New connection	248
39CP11A	New model	258
39CP09A	New model	260
39CP10A / 39CP12A	New model	261
47TB07 / 47TB08	New accessory	280
FT500	New accessory	286
DYBO	New accessory	290
E Easy manifold	Upgrade section	211
Selection Tab	Upgrade section	26-27
NG 16 x 1,5	New force color code	33
NG 24 x 1,5	New force color code	34
M 200 - 016 - A	New stroke	44
SC 500 - 200 - D	New stroke	119
SC 750 - SC 1500	New stroke	120-121
SC 3000 - SC 5000	New stroke	122-123
SC 7500	New stroke	124
H 1500	New model	133
H 2400 - 275 - D	New stroke	134
MP series	New series	166
MQ series	New series	174
KE 400 - 006 - A	New stroke	180
KE 1800 / KE 3000	New stroke	183-184
KE 4700 / KE 7500	New stroke	185-186
KE 12000 / KE 18500	New stroke	187-188
FB 63	New fixing	191
FBB 150 A	New fixing	193
FBC - FBD	New fixing	194-195
FBE - FBF	New fixing	196-197
FS3 - FCD	New fixing	201-202
FCQD 63	New fixing	204
FSE	New fixing	207
R 50 A / R 75 A / R 95 A	New fixing	208
ML - E Easy manifold	New model	214
SW - Secondary rod wiper	New accessory	228
39PR06A	New accessory	233
36M10B / 39M11B	New model	244
36HY400..	New connection	246-247
36P9/160...	New connection	247
39MCPC	New model	256
39CP14A	New model	262
39CP15A	New model	264
39CP16A	New model	265
39BD0601A / 39BD0801A	New accessory	266-267
39BD1001A / 39BD1201A	New accessory	268-269
39DDS01A	New accessory	278
47TB09	New accessory	280
58UT025A	New accessory	282
FT250 / FT 2000	New accessory	286-287
NITRO STRIP	New model	289

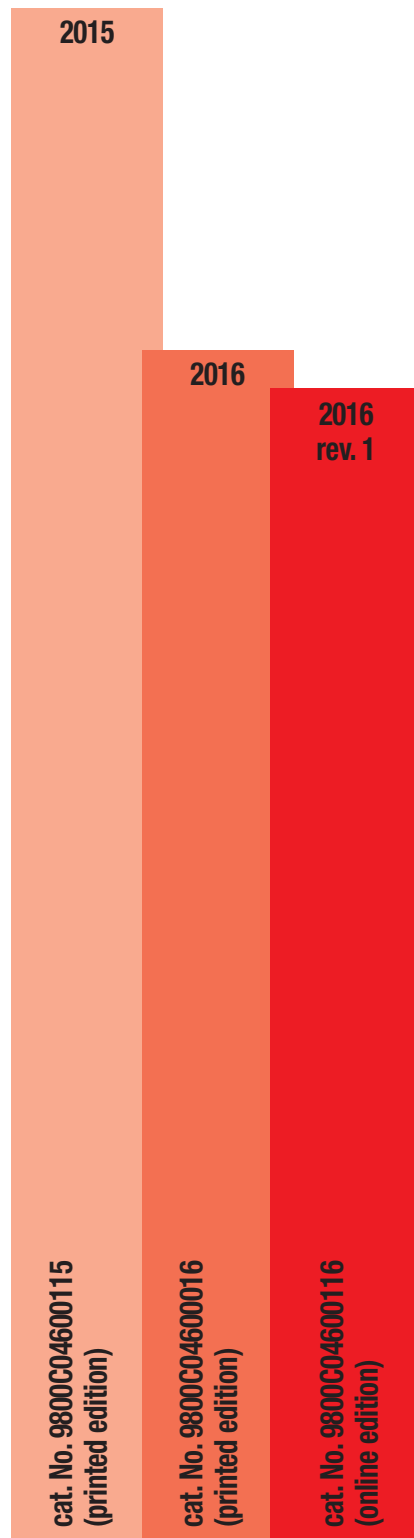

View updates online at: www.specialsprings.com

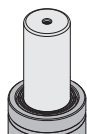

3D CAD FILES
www.partserver.com



SAFETY



User information

N₂ BENEFITS



How to read the catalog

Selection TAB

NE - NG
 VDI - BMW - FCA - Ford - GM - VW
Gas ejectors

M
 VDI - BMW - FCA - Ford - MB - PSA - VW
Mini cylinders

MS SKUDO
Mini cylinders

RV
 ISO - VDI - BMW - FCA - Ford - VW Mazda - MB - Nissan - PSA
Min. height, max. force

RS SKUDO
Min. height, max. force

RF G1/8 charging port
 FCA
Min. height, max. force

RG G1/8 charging port
Min. height, max. force

RT G1/8 charging port
 Mazda - Nissan - PSA - Toyota
Min. height, max. force

S
 MB - Renault - Suzuki
ISO forces, low profile

SC - SCF
 ISO - VDI - BMW - FCA - Ford - Mazda MB - Nissan - VW - PSA Renault - Suzuki
ISO 11901 Standard

H - HF
 ISO - VDI - BMW - FCA - VW
ISO, high force

LS
Zero force on contact

ML
Max. force, rod sealed

MP
Max. force, rod sealed

MQ
Max. force, rod sealed

KE SKUDO
Max. force, piston sealed



Fixings

easy MANIFOLD
Easy manifold systems

MANIFOLD
Standard manifold systems

SW
Secondary rod wiper



Hosed system



Accessories



NITRO STRIP
 UPG - AC - DYBO



SW

Raschiatore secondario
Secondary rod wiper
Zweitabstreifer
Racleur de tige secondaire
Rascador de vástago secundario
Anillo raspador secundário



More info:

p. 228

Benefits

IT

- Eccellente protezione da contaminanti liquidi e solidi
- Poliuretano ad alte prestazioni per massima resistenza chimica ai lubrificanti
- Aumentata durata di vita di guida e tenute dinamiche
- Minima perdita di corsa nominale
- Facile inserimento
- Nessuna limitazione al libero posizionamento del cilindro

DE

- ausgezeichnete Schutz gegen feste und flüssige Verunreinigungen
- maximale chemische Beständigkeit gegen Schmierstoffe durch das Hochleistungs-Polyurethan
- längere Lebensdauer für Führungselemente und dynamische Dichtungen
- minimaler Verlust des Nennhubes
- einfaches Einsetzen
- keine Einschränkungen für die Positionierung der Gasdruckfeder

ES

- Protección óptima contra los contaminantes líquidos y sólidos
- Máxima resistencia química a lubricantes gracias al poliuretano de alto rendimiento
- Mayor vida útil para elementos de guía y juntas dinámicas
- Pérdida mínima de carrera nominal
- Fácil de colocar
- Ninguna limitación para el posicionamiento del cilindro

EN

- Excellent protection from liquid and solid contaminants
- Maximum chemical resistance to lubricants thanks to high-performance polyurethane
- Longer lifetime for guiding elements and dynamic seals
- Minimal loss of nominal stroke
- Easy to insert
- No restrictions when positioning the cylinder

FR

- Excellente protection contre contaminants liquides et solides
- Résistance chimique maximale aux lubrifiants grâce au polyuréthane de haute performance
- Plus longue durée de vie pour les éléments de guidage et les joints dynamiques
- Perte minimale de la course nominale
- Facile à insérer
- Pas de limitations dans le positionnement du ressort-gaz

PT

- Excelente protecção contra contaminantes líquidos e sólidos
- Máxima resistência química aos lubrificantes graças ao poliuretano de alto desempenho
- Tempo de vida mais longo para os elementos de guiamento e vedações dinâmicas
- Perda mínima de curso nominal
- Fácil de inserir
- Não há restrições ao posicionar o cilindro



SKUDO

Protezione Attiva da Contaminanti
Active Protection from Contaminants
Aktiver Schutz vor Verunreinigungen
Protection Active contre les Contaminants
Protección Activa contra Contaminantes
Capa Protetora Contra Resíduos



Standard on: KE-RS-MS

Upon request for other models

Benefits

IT

- Elimina qualsiasi danno da contaminanti ai componenti di guida e tenuta
- Aumenta significativamente la vita del cilindro in presenza di contaminanti liquidi e solidi
- Non aumenta l'altezza del cilindro
- È una protezione non soggetta ad usura alcuna

DE

- Schützt vor Verunreinigungen, die Schäden an den Führungs- und Dichtungselementen hervorrufen
- Steigert erheblich die Lebenszeit der Gasdruckfeder bei erschwerten Arbeitsbedingungen
- Verändert die Gesamthöhe der Gasdruckfeder nicht
- Ist ein Schutz, der nicht verschleißt

ES

- Elimina daños de contaminantes a los componentes que garantizan la estanqueidad y guiado
- Aumenta significativamente la vida del cilindro en presencia de contaminantes líquidos y sólidos
- No aumenta la altura del cilindro
- Es una protección que no sufre desgaste

EN

- Eliminates damages to guiding and sealing components caused by contaminants
- Significantly increases the life of cylinders used in severe working environments
- Does not alter the height of the cylinder
- Does not wear out

FR

- Élimine tout endommagement du joint et des éléments de guidage du fait de contaminants
- Augmente de manière significative la vie du ressort en présence de contaminants liquides et solides
- Ne change pas la hauteur du ressort à gaz
- Est une protection qui n'est pas soumise à aucune usure

PT

- Elimina danos causados por resíduos nos anéis de vedação e guiamento
- Aumenta significativamente a vida dos cilindros usados em ambientes de trabalho com resíduos
- Não altera a altura do cilindro
- É uma protecção que não desgasta

VDI 3003

OSAS

Sicurezza Attiva Oltre Corsa
Over Stroke Active Safety
Aktive Überhubsicherung
Sécurité Active pour Surcourse
Seguridad Activa de Fin de Carrera
Segurança para Sobre Curso

VDI 3003

USAS

Sicurezza Attiva Ritorno Incontrollato
Uncontrolled Speed Active Safety
Aktiver Schutz bei unkontrolliertem Rückhub
Sécurité Active pour Retour Incontrôlé
Seguridad Activa de Retorno Incontrolado
Segurança para Retorno Descontrolado

VDI 3003

OPAS

Sicurezza Attiva Oltre Pressione
Over Pressure Active Safety
Aktive Überdruck-Sicherheitsvorrichtung
Sécurité Active Surpression
Seguridad Activa por Sobrepresión
Segurança Sobre Pressão

How it works?

IT

- Scarica in modo controllato e completo la pressione interna del cilindro quando ha subito un oltre corsa.

EN

- Exhausts pressure in a controlled and complete manner, when the cylinder has been overstroked.

DE

- Ermöglicht das kontrollierte und komplette Entladen des Innendrucks der Gasdruckfeder bei Überhub.

FR

- Décharge la pression du ressort en mode contrôlé et complet dans le cas d'une surcourse.

ES

- Descarga la presión de manera controlada y completa en caso de que el cilindro sobrepase su carrera máxima.

PT

- Esvazia a pressão do cilindro de forma controlada e completa quando ele sofre sobre-curso.

IT

- Scarica in modo controllato e completo la pressione del cilindro quando soggetto a ritorni incontrollati.

EN

- Exhausts pressure in a controlled and complete manner when the cylinder has been stressed by uncontrolled returns.

DE

- ermöglicht das kontrollierte und komplette Entladen des Innendrucks der Gasdruckfeder bei unkontrolliertem Rückhub.

FR

- Décharge la pression du ressort en mode contrôlé et complet dans de cas des retours non contrôlés.

ES

- Descarga la presión de manera controlada y completa en caso de que el cilindro sufra un retorno incontrolado.

PT

- Quando o cilindro sofrer retornos descontrolados, o mesmo se esvazia de uma maneira controlada e completa.

IT

- Scarica in modo controllato e completo la pressione del cilindro quando viene superato il valore massimo consentito.

EN

- Exhausts the pressure in a controlled and complete manner when it exceeds the maximum allowed value.

DE

- kontrollierte und vollständige Entladung des Innendrucks des Zylinders bei Überschreiten des maximal zulässigen Werts.

FR

- Décharge la pression du ressort en mode contrôlé et complet lorsque la valeur maximale admissible est dépassée.

ES

- Descarga la presión de manera controlada y completa cuando se supera el valor máximo permitido.

PT

- Esvazia a pressão do cilindro de forma controlada e completa quando ele excede o valor máximo permitido.

Benefits

IT

- Riduce il rischio di danni e pericoli dovuti alla proiezione di parti in pressione.
- Si attiva automaticamente senza intervento dell'operatore.
- Non aumenta il prezzo del cilindro.

EN

- Reduces the risk of tool damage or injury due to ejection of parts under pressure.
- Self activates automatically regardless of users' intervention.
- Does not increase the price of cylinders.

DE

- Reduziert das Risiko von Schäden und Gefahren durch wegschleudernde, unter Druck stehende Teile.
- Aktiviert sich automatisch ohne Zutun des Nutzers.
- Erhöht die Kosten der Gasdruckfeder nicht.

FR

- Réduit le risque d'endommagement de l'outil ou le risque de blessure en cas d'éjection de pièces ou composants sous pression.
- S'auto-active sans intervention de l'opérateur.
- N'augmente pas le prix du ressort.

ES

- Reduce el riesgo de daños y peligros consecuencia de la proyección de partes bajo presión.
- Se activa automáticamente sin intervención del usuario.
- No aumenta el precio del cilindro.

PT

- Reduz o risco de danos para a ferramenta e ferimentos para o operador por estilhaços.
- Ativa-se automaticamente independentemente de intervenção dos usuários.
- Não aumenta o preço dos cilindros.



**Over
Stroke
Active
Safety**

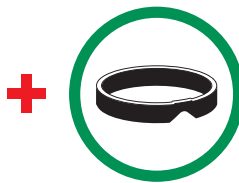

**Over
Stroke
Marker**

Standard on:
RV - RF - RS
RG - RT - S
SC - H - HF
LS

IT OSAS è la combinazione di un prolungamento verso l'esterno della boccola con delle discontinuità sulla parete di contatto della guarnizione boccola-corpo. OSAS si attiva senza deformazione del corpo.

FR OSAS est la combinaison d'un prolongement vers l'extérieur de la douille avec gorges discontinues sur la paroi de contact du joint douille-corps. OSAS s'auto-active sans déformer le corps du ressort.

EN OSAS is the combination of an outward extension of the bush with discontinuity groove on the body-bush sealing wall. OSAS self activates without deforming the body of the cylinder.

ES OSAS es la combinación de una extensión del casquillo con ranuras discontinuas en la pared de contacto cuerpo-casquillo. OSAS se activa sin deformaciones del cuerpo.

DE OSAS ist eine Kombination aus der Verlängerung der Buchse nach oben und der Auslaufrille an der Kontaktfläche der Dichtung Körper-Buchse. OSAS aktiviert sich ohne Deformation des Körpers.

PT OSAS é composto de dois pontos: uma extensão da bucha localizada para fora do corpo, e canais usinados na parte interna do corpo do cilindro onde acontece a vedação. O sistema OSAS é ativado sem deformar o corpo do cilindro.

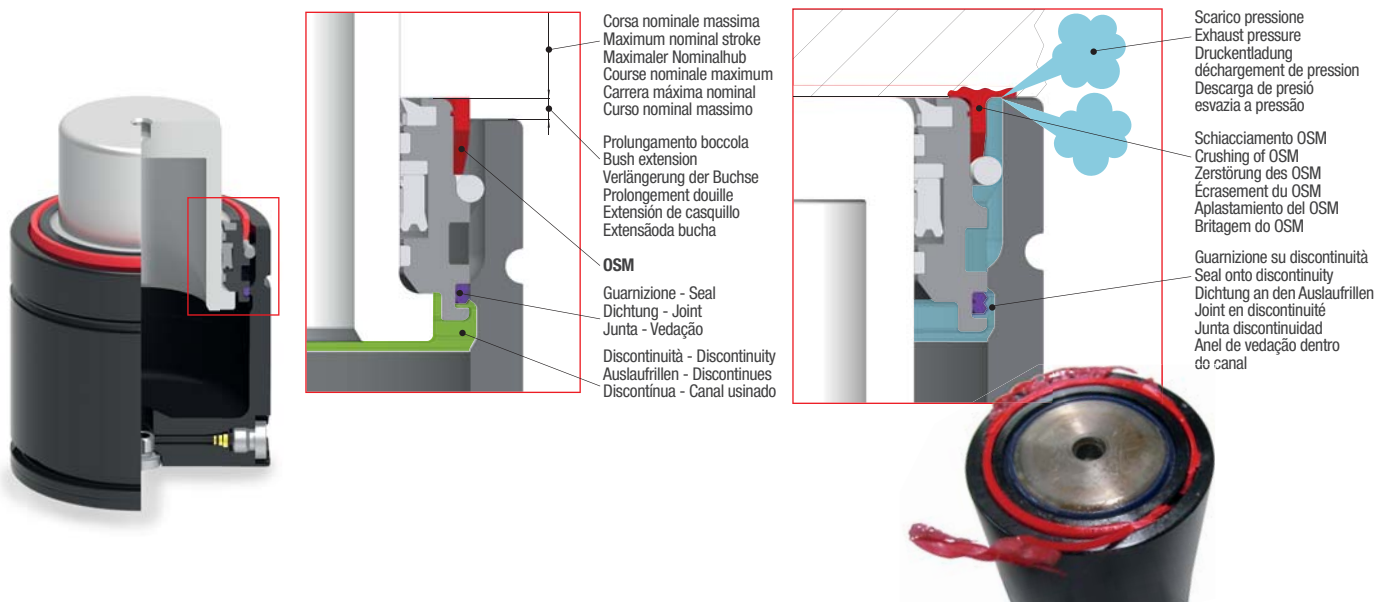

IT Il Marcatore Oltre Corsa OSM:
- permette di vedere immediatamente che il cilindro è stato utilizzato oltre la corsa nominale massima
- conferma che la sicurezza oltre corsa OSAS è stata attivata
- permette di intervenire tempestivamente sullo stampo eliminando la causa di oltre corsa
- non limita il libero posizionamento del cilindro
- aumenta la sicurezza di utilizzo dei cilindri ad azoto Special Springs

EN The Over Stroke Marker OSM:
- enables you to see immediately that the cylinder has been used over its maximum nominal stroke
- confirms that the Over Stroke Safety Feature OSAS has been activated
- allows you to act promptly on the die to remove the cause of the over stroke
- doesn't restrict the free positioning of the cylinder
- improves user safety for Special Springs' nitrogen cylinders

DE Der Überhubmarker OSM:
- ermöglicht es sofort zu sehen, dass die Gasdruckfeder über den maximalen Nennhub verwendet wurde.
- bestätigt, dass die OSAS Überhubsicherung aktiviert wurde.
- ermöglicht Ihnen, direkt die Ursache des Überhubes im Werkzeug zu beseitigen.
- schränkt die freie Positionierung der Gasdruckfeder nicht ein.
- verbessert die Anwendersicherheit für die Gasdruckfedern von Special Springs

FR Le Marqueur Surcourse OSM:
- vous permet de voir immédiatement que le ressort à gaz a été utilisé au-delà de la course nominale maximale
- vous confirme que le dispositif de sécurité contre les surcours OSAS a été activé
- vous permet d'agir rapidement sur le moule afin d'éliminer la cause de la surcourse
- ne limite pas un positionnement libre du ressort à gaz
- améliore la sécurité des utilisateurs des ressorts à gaz Special Springs

ES El Marcador de Sobrecarrera OSM:
- permite ver inmediatamente que el cilindro ha sido utilizado por encima de la carrera nominal máxima
- confirma que el dispositivo de seguridad contra sobrecarreras OSAS ha sido activado
- permite actuar con rapidez en el molde para eliminar la causa de la sobrecarrera
- no limita el posicionamiento libre del cilindro
- aumenta la seguridad del usuario de los cilindro de nitrógeno Special Springs

PT O Marcador do Sobre Curso OSM:
- permite ver imediatamente que o cilindro tem sido utilizado mais do curso nominal máximo
- confirma que o dispositivo de segurança contra sobre curso OSAS foi activado
- permite agir rapidamente no troquel para remover a causa do sobre curso
- não limita o posicionamento livre do cilindro
- aumenta a segurança do utilizador dos cilindros Special Springs



**Over
Stroke
Active
Safety**

**VDI
3003**

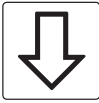

Standard on: ML - MP - MQ

IT OSAS è la combinazione di una zona deformabile del corpo con delle discontinuità sulla parete di contatto della guarnizione fondello-corpo. OSAS si attiva senza pericolo strutturale per il cilindro, aumentando ulteriormente la sicurezza per l'utilizzatore.

EN OSAS is the combination of a deformable body skirt with discontinuity groove on the body-bottom plate sealing wall. OSAS self activates without causing structural damages to the cylinder, further improving safety for users.

DE OSAS ist die Kombination einer deformierbaren Zone des Körpers mit Auslaufrillen an der Kontaktwand der Dichtung Körper-Boden. OSAS aktiviert sich ohne Strukturschäden am Zylinder, wodurch die Sicherheit für den Anwender verbessert wird.

FR OSAS est la combinaison d'une zone déformable du corps avec des gorges discontinues sur la paroi de contact du joint corps-plaque inférieure. OSAS s'auto-active sans provoquer de détériorations structurelles du vérin, améliorant ainsi la sécurité des opérateurs.

ES OSAS es la combinación de una zona deformable del cuerpo con ranuras discontinuas en la pared de contacto cuerpo-placa inferior. OSAS se activa sin peligro estructural para el cilindro, aumentando de manera importante la seguridad para el usuario.

PT OSAS é a combinação de uma área do corpo deformável com ranhura na parede de vedação inferior corpo-placa. OSAS ativa sem causar danos estruturais ao cilindro, melhorando ainda mais a segurança para os usuários.

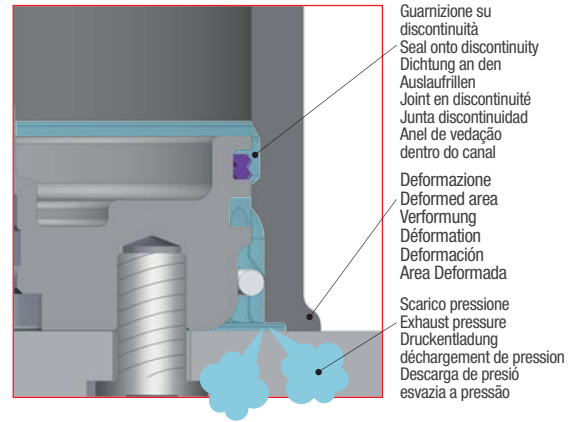
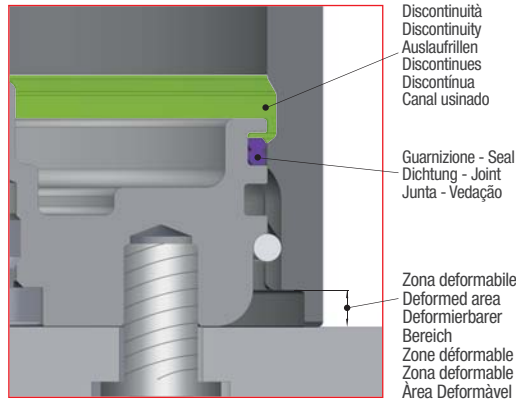

Standard on: KE

IT OSAS è realizzata con delle discontinuità sulla parete di contatto della guarnizione pistone. OSAS si attiva senza deformazione del corpo, aumentando ulteriormente la sicurezza per l'utilizzatore.

EN OSAS are discontinuity grooves on the body-piston sealing wall. OSAS self activates without deforming the body of the cylinder, further improving safety for users.

DE OSAS besteht aus Auslaufrillen an den Kontaktflächen der Kolbendichtung. OSAS aktiviert sich ohne eine Verformung des Körpers, wodurch die Sicherheit für den Anwender verbessert wird.

FR OSAS sont des gorges discontinues sur la paroi de contact du joint corps-piston. OSAS s'auto-active sans provoquer de déformation du vérin, améliorant ainsi la sécurité des opérateurs.

ES OSAS consiste en ranuras discontinuas en la pared de contacto cuerpo-pistón. OSAS se activa sin deformaciones del cuerpo, aumentando de manera importante la seguridad para el usuario.

PT OSAS é ativado com canais na parede de vedação do pistão. A OSAS é ativada sem deformação do corpo, aumentando ainda mais a segurança do usuário.

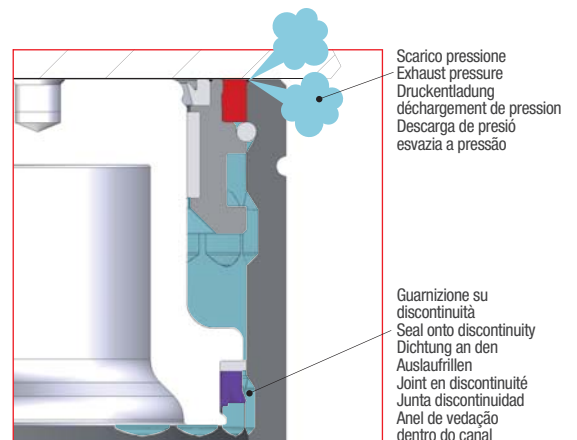
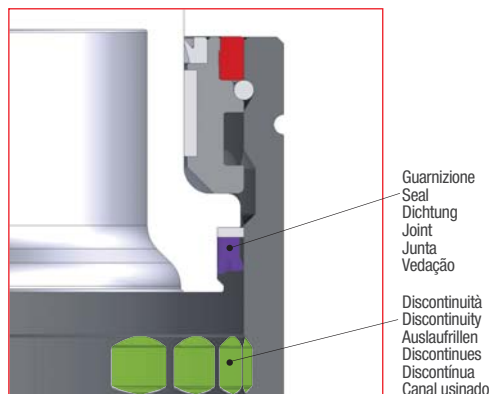

SAFETY



Uncontrolled
Speed
Active
Safety

VDI
3003



Standard on:
RV - RF - RS
RG - RT - S
SC - H - HF
LS

IT USAS è la combinazione di una zona deformabile della boccia in contatto con l'anello di ritegno a C e delle discontinuità sulla parete di contatto della guarnizione. USAS si attiva senza pericolo strutturale per il cilindro.

EN USAS is the combination of a deformable part of the bushing in contact with the retaining C-ring and the discontinuities on the wall of contact of the seal. USAS self activates without causing structural damages to the cylinder.

DE USAS besteht aus der Kombination eines verformbaren Bereichs der Buchse in Kontakt mit dem Sprengring und den Auslaufrillen auf der Kontaktwand der Dichtung. USAS aktiviert sich ohne die Gefahr von Strukturschäden am Zylinder.

FR USAS est la combinaison d'une zone déformable de la douille en contact avec le joint de retenue à C et des gorges discontinues sur la paroi de contact du joint. USAS s'auto-active sans déformer le corps du ressort-gaz.

ES USAS es la combinación de una zona deformable del casquillo en contacto con el anillo de sujeción y ranuras discontinuas en la pared. USAS se activa sin deformaciones del cuerpo.

PT USAS é a combinação de uma parte deformável da bucha em contato com o anel de retenção em C. Com o trabalho incorreto da haste sobre a bucha rompe-se o selo liberando a pressão do cilindro. USAS é ativado, sem causar danos estruturais ao cilindro.

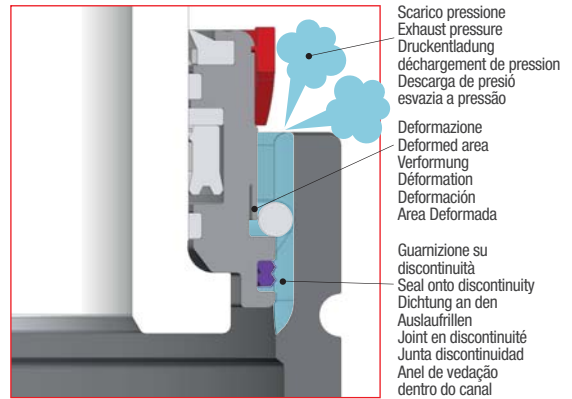
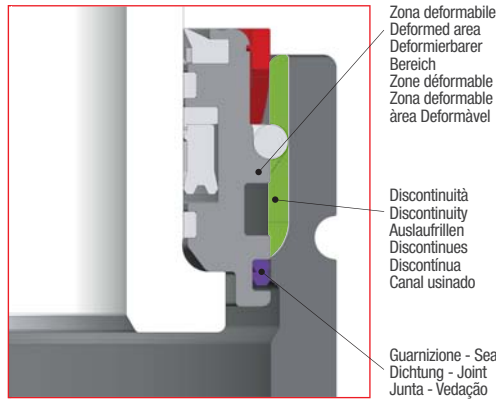

Standard on: ML - MP - MQ

IT USAS è la combinazione di una zona deformabile del fondello in contatto con l'anello di ritegno a C e delle discontinuità sulla parete di contatto della guarnizione. USAS si attiva senza pericolo strutturale per il cilindro.

EN USAS is the combination of a deformable part of the bottom plate in contact with the retaining C-ring and the discontinuities on the wall of contact of the seal. USAS self activates without causing structural damages to the cylinder.

DE USAS ist die Kombination eines deformierbaren Bereichs am Boden in Kontakt mit dem Sprengring und den Auslaufrillen an den Kontaktwänden der Dichtung. USAS aktiviert sich ohne die Gefahr von Strukturschäden am Zylinder.

FR USAS est la combinaison d'une zone déformable de la douille en contact avec la bague de retenue à C et des gorges discontinues sur la paroi de contact du joint. USAS s'auto-active sans provoquer des détériorations structurelles du ressort-gaz.

ES USAS es la combinación de una zona deformable de la placa inferior en contacto con el anillo de sujeción y ranuras discontinuas en la pared de contacto. USAS se activa sin peligro estructural para el cilindro.

PT USAS é a combinação de uma area deformável da placa base em contacto com o anel de retenção em C, e as ranhuras na parede de vedação corpo-placa base. USAS é ativado para não causar danos estruturais ao cilindro.

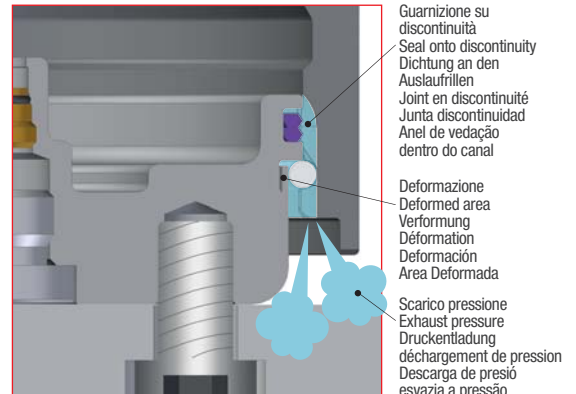
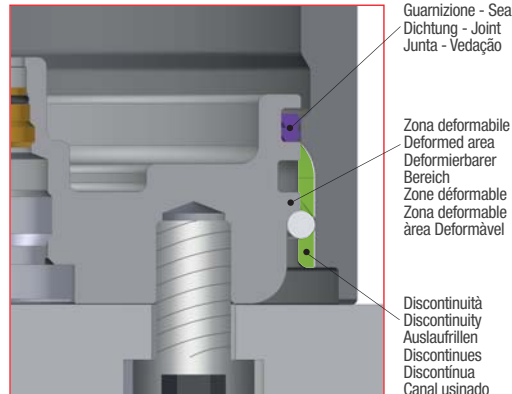

Standard on: **KE**

IT USAS è la combinazione di una zona deformabile della boccola in contatto con l'anello di ritegno a C e delle discontinuità sulla parete di contatto della guarnizione pistone. USAS si attiva senza pericolo strutturale per il cilindro.

EN USAS is the combination of a deformable part of the bushing in contact with the retaining C-ring and the discontinuities on the wall of contact of the piston seal. USAS self activates without causing structural damages to the cylinder.

DE USAS besteht aus der Kombination eines deformierbaren Bereichs der Buchse in Kontakt mit dem Sprengring und den Auslaufrillen an den Kontaktflächen der Kolbendichtung. USAS aktiviert sich ohne die Gefahr von Struktur-schäden am Zylinder.

FR USAS est la combinaison d'une zone déformable de la douille en contact avec le joint de retenue à C et des gorges discontinues sur la paroi de contact du joint corps-piston. USAS s'auto-active sans déformer le corps du ressort-gaz.

ES USAS consiste en la combinación de una zona deformable del casquillo en contacto con el anillo de sujeción y ranuras discontinuas en la pared de contacto cuerpo-pistón. USAS se activa sin deformaciones del cuerpo.

PT USAS é a combinação de uma parte deformável da bucha em contato com o anel de retenção em C, ao se deformar o pistão entra em uma área rebaixada do corpo. USAS é ativada decarregando a pressão evitando danos estruturais ao cilindro.

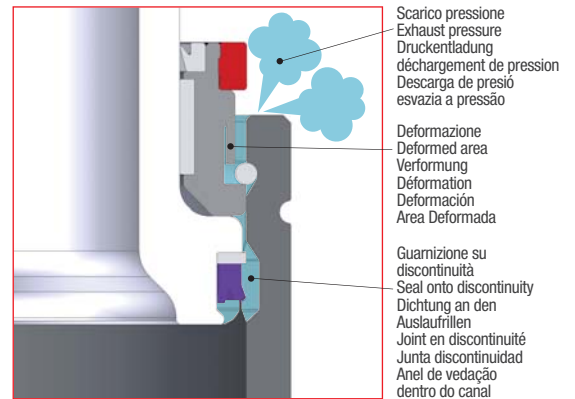
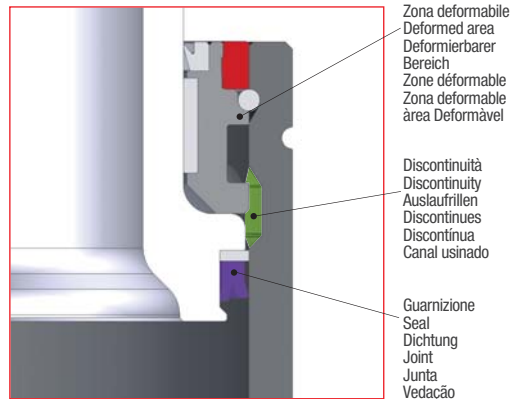

Over
Pressure
Active
Safety

VDI
3003



Standard on:
M - MS - RV - RS
RF - RG - RT - S
SC - H - HF - LS
ML - MP - MQ - KE

IT OPAS è la combinazione di un setto di rottura calibrato integrale sul fondello o un tappo di rottura montato sul corpo del cilindro, con una fresatura di scarico sulla base di appoggio.

EN OPAS is either the combination of a rupture septum or a rupture plug positioned in the bottom of the cylinders, with an exhaust milling on the bottom contact surface.

DE Je nach Bauweise der Gdf. ist OPAS die Kombination aus einer kalibrierten, im Boden integrierten Sollbruchstelle oder einem im Zylinderkörper eingesetzten Sollbruchstopfen und der Auslaufrille in der Auflagefläche.

FR OPAS est un cloison de rupture calibré intégral sur la plaque inférieure ou un bouchon de rupture monté sur le plateau du cylindre, avec une fraisure de déchargement sur la base d'appui.

ES OPAS es la combinación de un setto de rotura o bien de un tapón de rotura posicionados en la base del cilindro, con un fresado de descarga en la base de apoyo.

PT OPAS é a combinação de um setto calibrado ou uma plugue de ruptura posicionado na parte inferior dos cilindros, com uma saída de escape na superfície inferior de contacto.

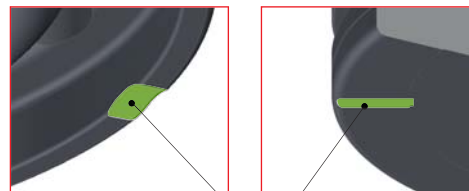
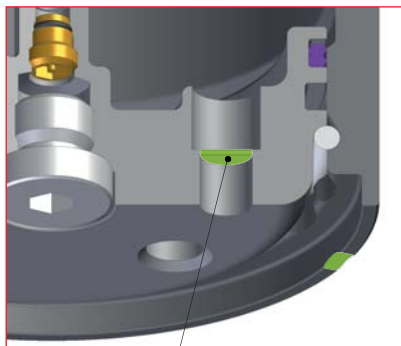

Fresatura di scarico - Exhaust milling - Auslaufrille
Fraisage de déchargement - Fresado de descarga - Área de saída de pressão

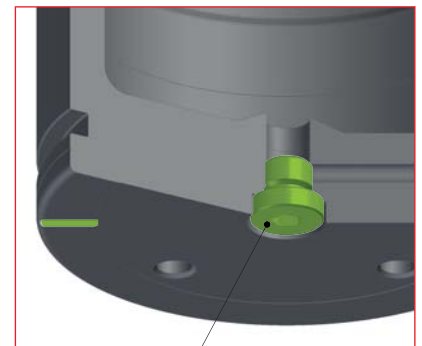

Setto di rottura - Rupture septum - Sollbruchstelle
Cloison de rupture - Septo de ruptura - Septo de ruptura

Tappo di rottura - Rupture plug - Sollbruchstopfen
Bouchon de rupture - Tapón de ruptura - Plugue de ruptura

1381



PED 2014/68/EU

IT

- La progettazione e la produzione dei cilindri a gas Special Springs sono realizzate nel pieno rispetto delle normative vigenti per i recipienti in pressione come stabilito dalla direttiva PED 2014/68/EU e EN 13445:2015.

EN

- The design and manufacturing of Special Springs gas cylinders are in full compliance with the European regulations for high pressure vessels, in accordance with directive PED 2014/68/EU and EN 13445:2015.

DE

- Die Konstruktion und Herstellung der Gasdruckfedern Special Springs erfolgt in Übereinstimmung mit den geltenden Normen für Druckbehälter, wie in der PED Richtlinie 2014/68/EU und EN 13445:2015 festgelegt.

FR

- La conception et la fabrication des ressorts à gaz Special Springs sont en totale conformité avec les législations européennes en matière de composants caractérisés haute pression et notamment avec la directive PED 2014/68/EU et EN 13445:2015

ES

- La proyectación y producción de los cilindros de nitrógeno Special Springs se realizan con pleno respeto de las normativas vigentes para elementos de presión como establece la directiva PED 2014/68/EU y EN 13445:2015.)

PT

- O projeto e fabricação de cilindros de Nitrogênio Special Springs estão em total conformidade com as regras Europeias para Cilindros de alta pressão, em conformidade com a directiva PED 2014/68/EU e EN 13445:2015.

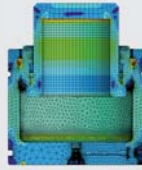

FEM - CAE

IT

- Tutti i prodotti Special Springs sono sviluppati e validati con l'utilizzo dei più avanzati sistemi di analisi FEM (finite element method) e CAE (computer aided engineering)

EN

- All Special Springs products are developed and validated via the use of the most advanced FEM (finite element method) and CAE (computer aided engineering) analysis systems

DE

- Alle Produkte von Special Springs werden durch die Verwendung der fortschrittlichsten Analysensysteme FEM (finite element method) und CAE (computer aided engineering) entwickelt und validiert.

FR

- Tous les produits Special Springs sont développés et certifiés selon les méthodes FEM (finite element method) et CAE (Computer aided engineering)

ES

- Todos los productos Special Springs son desarrollados y validados con la utilización de los más avanzados sistemas de análisis FEM (finite element method) y CAE (computer aided engineering)

PT

- Todos os produtos Special Springs são desenvolvidos e validados através da utilização das Técnicas mais avançadas FEM (método de elementos finitos) e sistemas de análise de CAE (Engenharia assistida por computador).

> 2.000.000

STRUCTURE OF THE GAS CYLINDER

IT

- Tutti i componenti strutturali delle molle a gas Special Springs sono progettati e costruiti per supportare minimo 2.000.000 di cicli completi alla massima pressione, temperatura e per ogni tipo di fissaggio.

EN

- All structural components of Special Springs nitrogen cylinders are designed and built to withstand a minimum of 2,000,000 complete cycles at maximum pressure, temperature and for all types of fixings.

DE

- Alle Strukturkomponenten der Special Springs Gasdruckfedern sind konstruiert und hergestellt, um mindestens 2.000.000 komplette Zyklen bei maximalem Druck und Temperatur zu erreichen, unter Verwendung jeder für das jeweilige Modell empfohlener Befestigungsart.

FR

- Tous les composants structureaux des ressorts gaz Special Springs sont conçus et construits pour supporter un minimum de 2 million des cycles complètes à la pression et température maximale pour chaque type de fixation.

ES

- Tutti i componenti strutturali delle molle a gas Special Springs sono progettati e costruiti per supportare minimo 2.000.000 di cicli completi alla massima pressione, temperatura e per ogni tipo di fissaggio.

PT

- Todos os componentes estruturais dos cilindros Special Springs, são projetados e construídos para suportar no mínimo 2.000.000 ciclos com máxima pressão, temperatura e para todos os tipos de dispositivos de fixação.

Benefits

IT

- Maggiore garanzia di prodotti e componenti sicuri per il cliente.

EN

- Greater assurance of safe products and components for customers.

DE

- verbesserte Sicherheit für den Kunden durch sichere Produkte und Komponenten.

FR

- Plus grande assurance de produits et composants sûrs pour les clients.

ES

- Mayor garantía de productos y componentes seguros para los clientes.

PT

- Maior garantia de produtos e componentes seguros para os clientes.



KNOWLEDGE

IT

- La conoscenza è un elemento fondamentale per azioni quotidiane di successo, più conosciamo meglio facciamo. Questo concetto è da sempre presente nella filosofia del lavoro di Special Springs. Da molti anni Special Springs è impegnata per aumentare la conoscenza dei prodotti e delle loro caratteristiche unitamente alle migliori tecniche di utilizzo attraverso formazioni teoriche e pratiche.

EN

- Knowledge is an essential element for successful daily actions; the more we know, the better we perform. This concept has always been one of Special Springs' core values. For many years the company has committed to increase knowledge of products along with their characteristics and their best utilisations techniques, through theoretical and practical training.

DE

- Fachkenntnis ist ein grundlegendes Element für tagtägliche Tätigkeiten mit Erfolg, je mehr wir wissen, desto besser können wir handeln. Dieses Konzept ist schon immer die Arbeitsphilosophie von Special Springs. Seit vielen Jahren ist Special Springs bestrebt, die Fachkenntnisse rund um die Produkte und ihre technischen Eigenschaften zusammen mit den neuesten Anwendungstechniken durch theoretische und praktische Schulungen zu vertiefen.

FR

- La connaissance est un élément fondamental pour les actions quotidiennes de succès, le plus on connait, le mieux on fait. Ce concept a été toujours présent dans la philosophie de travail de Special Spring. Depuis plusieurs années Special Spring s'est engagé à augmenter la connaissance des produits et de ses caractéristiques mais aussi aux meilleures techniques d'usage à travers formations théoriques et pratiques.

ES

- El conocimiento es un elemento fundamental para acciones cotidianas que lleven al éxito, cuanto más se conoce mejor se hace. Este concepto ha estado siempre en la filosofía de trabajo de Special Springs. Special Springs se dedica desde hace muchos años a aumentar su conocimiento sobre los productos y sus características, así como a mejorar las técnicas de uso a través de formaciones teóricas y prácticas.

PT

- O conhecimento é um elemento essencial para o sucesso das ações diárias; Quanto mais soubermos, melhor nós executamos. Este conceito sempre foi um dos valores da Special Springs. Por muitos anos a empresa se comprometeu a aumentar os conhecimentos dos produtos juntamente com suas características e suas melhores técnicas de utilizações através de formação teórica e prática.



TECHNICAL SUPPORT

IT

- Special Springs, da sempre impegnata per migliorare il supporto tecnico agli utilizzatori, fornisce con ogni cilindro o suo componente un completo foglio di istruzioni multilingua.

EN

- Special Springs has always been committed to provide technical support for users; we provide a thorough multilingual instruction sheet with each cylinder or component.

DE

- Special Springs ist schon immer bestrebt, den technischen Support der Anwender zu verbessern, für jede Gasdruckfeder und deren Komponenten ist eine mehrsprachige Betriebsanleitung verfügbar.

FR

- Special Springs s'est engagée depuis longtemps pour améliorer le support technique aux utilisateurs, elle fournit avec chaque ressort ou composant un papier d'instruction multilingue complet.

ES

- Es prioridad desde siempre para Special Springs la mejora del soporte técnico al usuario, para lo que entrega un completo manual en varios idiomas con el cilindro o componente.

PT

- A Special Springs é empenhada em fornecer suporte técnico para usuários; Nós fornecemos uma folha de instruções multilingue completa com cada cilindro ou componente.

Benefits

IT

- Maggiore conoscenza degli utilizzatori sui reali vantaggi offerti dai cilindri a gas Special Springs.
- Maggiore conoscenza degli utilizzatori sui più corretti metodi di utilizzo con vantaggi economici e di sicurezza.
- Maggiore sensibilità e coscienza sull'importanza delle sicurezze attive sui cilindri a gas.

EN

- Increased knowledge of users, in regards to the real benefits given by Special Springs gas cylinders.
- Increased knowledge of users on how to appropriately use the products, hence benefit from cost and production efficiency.
- Increased knowledge of users on the importance of our gas cylinders safety features.

DE

- größeres Wissen der Anwender über die effektiven Vorteile der Special Springs Gasdruckfedern.
- größeres Wissen der Anwender über die am besten geeigneten Anwendungsverfahren mit wirtschaftlichen und sicherheitsrelevanten Vorteilen.
- besseres Verständnis bzw. Bewusstsein der Wichtigkeit der aktiven Sicherheitselemente an Gasdruckfedern.

FR

- Majeure connaissance des utilisateurs sur les avantages réels offerts par les ressorts à gaz Special Spring.
- Majeure connaissance des utilisateurs sur les méthodes de usage plus correctes avec avantages économiques et de sécurité.
- Majeure sensibilité et conscience sur l'importance des sécurités actives dans les ressorts à gaz.

ES

- Mayor conocimiento por parte del usuario de las ventajas ofrecidas por los cilindros Special Springs.
- Mayor conocimiento por parte del usuario de los métodos correctos para aumentar la seguridad de uso.
- Mayor sensibilidad y conciencia de la importancia de la seguridad activa en los cilindros de nitrógeno.

PT

- Aumento do conhecimento dos usuários, no que diz respeito aos benefícios reais dados pelo Cilindro de Nitrogênio Special Springs.
- Aumento do conhecimento dos usuários sobre como usar adequadamente os produtos, portanto, aumentando a eficiência de custo e produção.
- Aumento do conhecimento dos usuários sobre a importância de nossas características de segurança do cilindros de Nitrogênio.

OPERATING INSTRUCTION



- IT** Caricare soltanto con GAS AZOTO (N₂).
- EN** Charge only with NITROGEN GAS (N₂).
- DE** Gasdruckfedern dürfen nur mit STICKSTOFF GAS (N₂) gefüllt werden.
- FR** Charge seulement avec du GAZ AZOTE (N₂).
- ES** Cargar únicamente con GAS NITROGENO (N₂).
- PT** Carregar somente com GÁS de NITROGÊNIO (N₂).

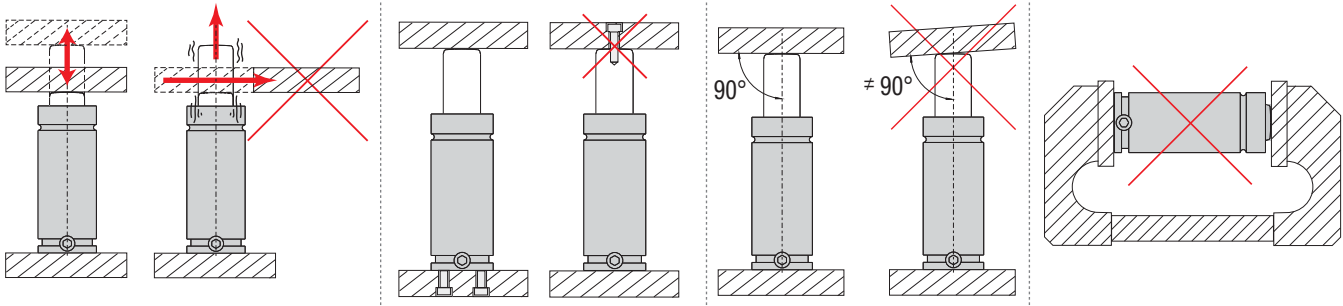

IT Tutti i cilindri Special Springs sono dotati di riserva corsa da 1 a 3 mm (escluso M90/TBM-TBI-TEM). Quindi il valore nominale Cu è completamente utilizzabile. Si raccomanda comunque di non eccedere il 90% di Cu nell'uso pratico per prevenire eventuali extra-corse, causate da modifiche o errori sugli stampi, con danni irreparabili ai cilindri e gravi rischi per la sicurezza.

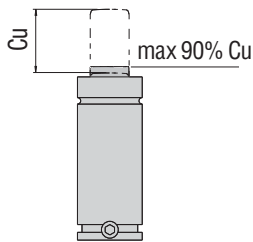

EN All Special Springs nitrogen cylinders are designed with a stroke reserve from 1 to 3 mm (except M90/TBM-TBI-TEM). Therefore, the nominal value (Cu) is fully applicable. However, it is recommended not to exceed 90% of Cu in practical use in order to avoid the risk of any extra stroke caused by changes or errors in tools. This would result in irreparable damages to the cylinders and serious danger to personnel.

DE Alle Gasdruckfedern von Special Springs verfügen über eine Hubreserve von 1 ÷ 3mm (Ausnahme: M90/TBM-TBI-TEM). Daher kann der Nennwert Cu zu 100% verwendet werden. Wir empfehlen jedoch, im praktischen Einsatz nur 90% des angegebenen Cu-Wertes zu verwenden, um einen eventuellen Überhub zu vermeiden, der durch Änderung oder Fehlfunktion des Werkzeuges verursacht werden kann und zu irreparablen Schäden an der Gasdruckfeder und an dem Werkzeug führen kann, sowie ein schwerwiegendes Sicherheitsrisiko für den Anwender darstellt.

FR Tous les cylindres Special Springs sont munis d'une course de réserve de 1 ÷ 3 mm (sauf M90/TBM-TBI-TEM). Donc, la valeur nominale Cu peut être utilisée complètement. Il est en tout cas conseillé de ne pas dépasser 90% de Cu lors de l'utilisation normale, pour éviter toute course supplémentaire engendrée par des modifications ou des erreurs sur les moules; ce qui entraînerait des dommages irréparables aux cylindres et de graves risques pour la sécurité.

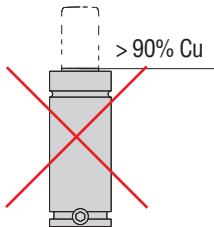

ES Todos los cilindros Special Springs están dotados de un margen adicional de carrera de 1 ÷ 3 mm (excepto M90/TBM-TBI-TEM). Esto significa que el valor nominal Cu es completamente utilizable. De todos modos, no deja de ser aconsejable no superar el 90% de Cu en el uso práctico, para así prevenir posibles sobre carreras, causadas por modificaciones o errores en los moldes, con daños irreparables a los cilindros y graves riesgos de seguridad.

PT Todos os cilindros Special Springs dispõem de reserva para pressões súbitas de 1 ÷ 3 mm (excluindo o M90/TBM-TBI-TEM). Assim, o valor nominal Cu é completamente utilizável. Recomenda-se no entanto que não se excedam os 90% de Cu na utilização prática para prevenir eventuais pressões súbitas mais fortes, causadas por modificações ou erros nas estampagens, com danos irreparáveis nos cilindros e graves riscos para a segurança.

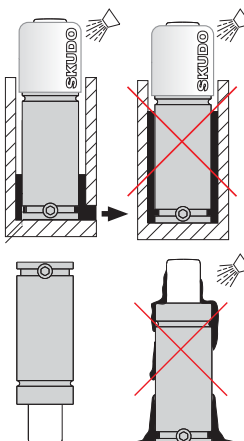

IT In presenza di contaminanti liquidi o solidi utilizzare cilindri con SKUDO. In mancanza di cilindri con SKUDO, un miglioramento significativo si ottiene installando i cilindri capovolti.

EN In presence of liquid or solid contaminants, use cylinders with SKUDO. In absence of cylinders with SKUDO protection, a significant improvement could be obtained by mounting the cylinders in upside-down position.

DE Verwenden Sie in Bereichen, in denen die Gasdruckfeder dem Einwirken von Flüssigkeiten oder Schmutzpartikeln ausgesetzt ist, Gasdruckfedern mit SKUDO. Wenn SKUDO nicht eingesetzt werden kann, empfehlen wir, die Gasdruckfeder mit nach unten stehendem Kolben zu montieren, um das Eindringen der Flüssigkeit oder der Schmutzpartikel in die Gasdruckfeder zu vermeiden.

FR En présence de contaminants liquides ou solides, utiliser les ressorts avec SKUDO. En absence de ressorts avec SKUDO, une amélioration importante peut s'obtenir en montant les cylindres renversés.

ES En presencia de contaminantes líquidos o sólidos, utilice cilindros con SKUDO. A falta de cilindros con SKUDO, una notable mejora se obtiene montando los cilindros volcados.

PT Em presença de contaminadores líquidos o sólidos, usar cilindro com SKUDO. Na falta de cilindro com protecção SKUDO, obtém-se uma significativa melhoria montando os cilindros de cabeça para baixo.

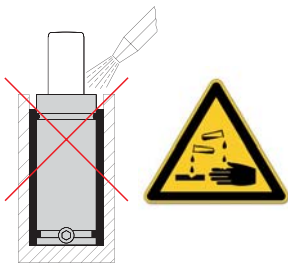

IT Evitare il contatto di fluidi aggressivi (soda e cloruri) con i cilindri. Se utilizzati per la pulizia dello stampo, si raccomanda di rimuovere dai cilindri ogni residuo.

EN Avoid any contact of cylinders with aggressive fluids (soda or chlorites). If they are used for cleaning the tools, we recommend to carefully remove any residue from cylinders.

DE Werden aggressive Flüssigkeiten (Soda oder Chloride) zur Reinigung des Werkzeugs verwendet, dürfen sie nicht mit den Gasdruckfedern in Kontakt kommen bzw. jeglicher Rückstand davon muss von den Gasdruckfedern entfernt werden.

FR Éviter le contact des liquides agressifs (soda ou chlorites) avec les cylindres. S'ils sont utilisés pour le nettoyage des moules, il est recommandé d'enlever tous résidus sur les cylindres.

ES Evite el contacto de fluidos agresivos (soda o cloruro) con los cilindros. Si se utilizan para la limpieza de herramientas, recomendamos eliminar cualquier residuo de los cilindros.

PT Evitar qualquer contacto dos cilindros com fluidos agressivos (soda ou cloretos). Se forem usados para limpar ferramentas, recomendamos remover todos os resíduos dos cilindros.

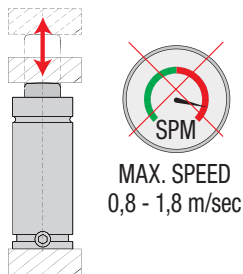

IT Non confondere la velocità massima con il numero massimo di cicli al minuto, come raccomandato per ogni modello.

EN Do not confuse the maximum speed with the maximum number of strokes per minute, as recommended for each model.

DE Die maximale Geschwindigkeit darf nicht mit der maximalen Hubzahl pro Minute verwechselt werden, wie dies für jedes Modell empfohlen wird.

FR Ne confondez pas la vitesse maximale avec le nombre maximal de coups par minute, comme recommandé pour chaque modèle.

ES No debe confundirse la velocidad máxima con el número máximo de golpes por minuto, tal como se recomienda para cada modelo.

PT Não confunda a velocidade máxima com o número máximo de golpes por minuto, conforme o recomendado para cada modelo.

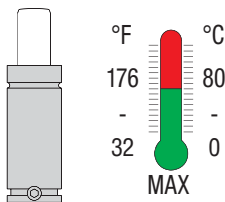

IT Temperatura di funzionamento

EN Operating temperature

DE Arbeitstemperatur

FR Température de fonctionnement

ES Temperatura de funcionamiento

PT Temperatura de operação

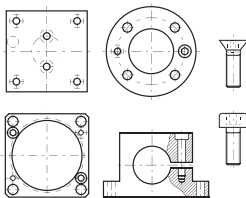

IT Si raccomanda di fissare sempre i cilindri con gli appositi elementi di fissaggio.

EN It is always recommended to fix the gas springs with the suitable fixing elements.

DE Es wird immer empfohlen, die Gasdruckfedern mit den geeigneten Befestigungselementen zu fixieren.

FR Il est toujours recommandé de fixer les cylindres avec les éléments de fixation appropriés.

ES Se recomienda fijar siempre los cilindros con los elementos de fijación apropiados.

PT É aconselhável fixar sempre os cilindros com os elementos de fixação adequados.

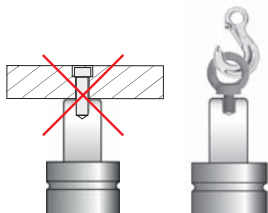

IT Utilizzare il foro filettato sullo stelo solo per la movimentazione dei cilindri.

EN Use the threaded hole on the rod only for gas springs' handling.

DE Die Gewindebohrung an der Kolbenstange ist ausschließlich für die Handhabung der Gasdruckfedern zu verwenden.

FR Utiliser le trou fileté sur la tige uniquement pour la manipulation des cylindres.

ES Utilizar el orificio roscado en el vástago solo para la manipulación de los cilindros.

PT Utilizar o furo roscado na haste só para o manuseio dos cilindros.

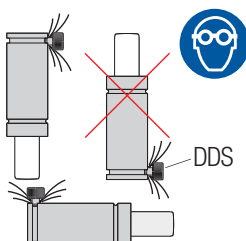

IT Durante lo scaricamento con l'uso del dispositivo DDS, orientare il flusso del gas in direzione opposta all'operatore.

EN When discharging by using a DDS device, direct the gas flow away from operator.

DE Während der Entladung mit Hilfe der DDS-Vorrichtung, richten Sie den Gasfluss in die dem Bediener entgegengesetzte Richtung.

FR Pendant le déchargement à l'aide du dispositif DDS, orientez le flux du gaz dans la direction opposée à l'opérateur.

ES Durante la descarga mediante el dispositivo DDS, orientar el flujo del gas en dirección contraria al operador.

PT Durante a descarga com a utilização do dispositivo DDS, orientar o fluxo de gás na direção oposta à do operador.

OPERATING INSTRUCTION

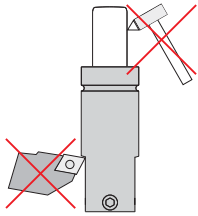

- IT** Evitare qualsiasi lavorazione meccanica o impatto su corpo e stelo.
- EN** Avoid any mechanical tooling or impact on the body and the rod.
- DE** Vermeiden Sie mechanische Bearbeitungen jeder Art oder sonstige Einwirkungen auf Körper und Kolbenstange.
- FR** Éviter toute opération mécanique ou impact sur le corps et la tige.
- ES** Evitar toda clase de elaboraciones mecánicas o de impactos en el cuerpo y en el vástago del cilindro.
- PT** Evitar qualquer trabalho mecânico ou impacto sobre o corpo e haste.



- IT** Se un cilindro ha la struttura danneggiata, prima di qualsiasi manipolazione, scaricare completamente la pressione.
- EN** If a cylinder has structural damage, fully exhaust all pressure before any form of handling.
- DE** Weist die Gasdruckfeder Beschädigungen auf, muss vor dem Eingriff der Druck vollständig abgelassen werden.
- FR** Si la structure d'un cylindre est endommagée, décharger complètement la pression, avant d'effectuer toute opération.
- ES** Si un cilindro presenta desperfectos en su estructura, descargar completamente la presión antes de proceder a revisarlo.
- PT** Se um cilindro tiver a estrutura danificada, antes de qualquer manipulação, descarregar completamente a pressão.

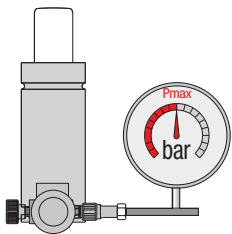

- IT** Durante il caricamento non eccedere la pressione massima raccomandata per ogni modello.
- EN** When charging do NOT exceed the maximum recommended pressure for each model.
- DE** Überschreiten Sie während der Ladung den für jedes Modell angegebenen Druckwert nicht.
- FR** Durant le chargement, il est conseillé de ne pas dépasser la pression maximum recommandée pour chaque modèle.
- ES** Durante la carga, no superar nunca la presión máxima aconsejada para cada modelo.
- PT** Durante a carga, não exceder a pressão máxima recomendada para cada modelo.

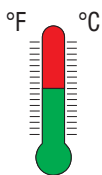

± 1 °C = ?
⇓
approx. ± 0,33 % P

- IT** Ogni variazione della temperatura, rispetto al valore nominale di calcolo di 20°C, determina una variazione della pressione del gas (P).
- EN** Any variation in temperature, respect to the nominal calculation value of 20°C, causes a change in gas pressure (P).
- DE** Jede Temperatur, die vom berechneten Nennwert (20°C) abweicht, bewirkt eine Änderung des Gasdrucks (P).
- FR** Chaque modification de la température, par rapport à la valeur nominale de calcul de 20°C, détermine une modification de la pression du gaz (P).
- ES** Toda variación de la temperatura con respecto al valor nominal de cálculo de 20°C, determina una variación de la presión del gas (P).
- PT** Qualquer variação da temperatura, no que respeita ao valor nominal de cálculo de 20°C, determina uma variação da pressão do gás (P).

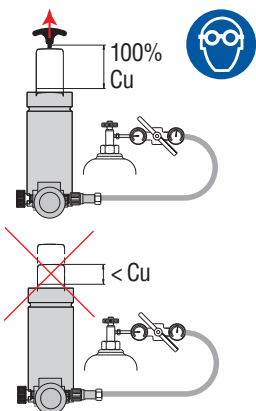

- IT** Durante il caricamento assicurarsi che lo stelo sia estratto al 100%. Per cilindri privi di foro filettato sullo stelo, caricare inizialmente con 5 bar (75 psi) per estrarre completamente lo stelo, quindi procedere fino alla pressione desiderata.
- EN** Ensure that the rod is 100% extracted when charging. For cylinders without a threaded hole on the rod, initially charge to 5 bar (75 psi) to extract the rod completely, then charge to the required.
- DE** Stellen Sie vor der Befüllung der Gasdruckfeder sicher, dass die Kolbenstange ganz ausgefahren ist. Befüllen Sie Gasdruckfedern ohne Gewinde am Ende der Kolbenstange anfangs nur mit 5 bar (75 psi), um die Kolbenstange vollständig in die ausgefahrene Position zu drücken. Steigern Sie anschließend den Befülldruck auf den gewünschten Wert.
- FR** Durant le chargement, s'assurer que la tige soit complètement sortie. Les cylindres sans trou fileté sur la tige doivent être chargés initialement sous 5 bars (75 psi) pour extraire complètement la tige; procéder ensuite jusqu'à la pression désirée.
- ES** Durante la carga, asegurarse de que el vástago sea extraído al 100%. En cilindros con vástago sin orificio roscado, comenzar con una carga de 5 bar (75 psi) a fin de extraer completamente el vástago. Sólo entonces proseguir cargando hasta alcanzar la presión deseada.
- PT** Durante a carga, assegure-se de que o haste esteja totalmente extraído. Para cilindros sem orifício roscado no haste, carregar inicialmente com 5 bar (75 psi) para extrair completamente haste, depois, proceder até à pressão desejada.



- IT** Prima di gettare qualsiasi cilindro a gas scaricare completamente la pressione.
- EN** Before disposing of a gas spring ensure that all residual pressure is fully exhausted.
- DE** Vor der Entsorgung muss jede Gasdruckfeder vollständig entleert werden.
- FR** Décharger complètement la pression, avant de jeter tout cylindre à gaz.
- ES** Nunca tirar un cilindro de gas sin antes haber descargado por completo la presión.
- PT** Antes de deitar fora qualquer cilindro a gás, descarregar completamente a pressão.



NON SELF CONTAINED

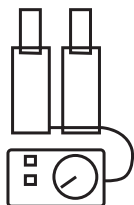

IT Tutti i cilindri collegabili a sistema e specificatamente codificati (_ - N / _ - NA) sono forniti senza valvola unidirezionale, senza pressione e con il solo tappo di chiusura del foro di collegamento (escluso M90, M200, RV170, RV320). Nel caso si desideri trasformare dei cilindri autonomi in cilindri collegabili a sistema è sufficiente ordinare i raccordi e i tubi necessari e seguire le istruzioni specifiche per ogni serie pubblicate nel sito www.specialsprings.com.

EN All cylinders which can be connected to the system and are specifically coded (_ - N / _ - NA) are supplied without the one-way valve, without pressure and with only the closure plug of the connection hole (excluding M90, M200, RV170, RV320). If you wish to convert independent cylinders into system-connectable cylinders, order the necessary hoses and connections, and follow the specific instructions for every series published on site www.specialsprings.com.

DE Alle Gasdruckfedern, die in ein Verbundsystem integrierbar sind und mit entsprechenden Zusatzangaben (_ -N/ _ -NA) bestellt werden, werden ohne Rückschlagventil, unbefüllt und nur mit der in der Anschlussöffnung montierten Verschlusschraube geliefert (Ausnahmen: M90, M200, RV170, RV320). Sollen eigenständig arbeitende Gasdruckfedern für die Nutzung in einem Verbundsystem umgebaut werden, genügt es, die erforderlichen Anschlüsse und Leitungen zu bestellen, sowie die für die jeweilige Serie auf der Internetseite www.specialsprings.com veröffentlichten Hinweise zu beachten.

FR Tous les cylindres qui peuvent être raccordés au système et qui possèdent un code d'identification spécifique (_ - N / _ - NA) sont fournis sans valve unidirectionnelle ni pression. Seul le bouchon de fermeture de l'orifice de raccordement est fourni (sauf M90, M200, RV170, RV320). Au cas où l'on souhaiterait transformer des cylindres autonomes en cylindres à système raccordables, il suffira de commander les raccords et les tubes nécessaires puis de suivre les instructions spécifiques de chaque série, publiées sur le site www.specialsprings.com.

ES Todos los cilindros que se pueden conectar al sistema, específicamente codificados (_ - N / _ - NA), se suministran sin válvula unidireccional y sin presión, sólo con el tapón de cierre del orificio de conexión (menos M90, M200, RV170, RV320). Si se desea transformar cilindros autónomos en cilindros conectables a sistema, es suficiente pedir los empalmes y los tubos necesarios y seguir las instrucciones específicas para cada serie publicadas en el sitio www.specialsprings.com.

PT Todos os cilindros que podem ser ligados ao sistema e especificamente codificados (_ - N / _ - NA) são fornecidos sem válvula unidireccional, sem pressão e somente com a tampa de fechamento do furo de ligação (Não incluída M90, M200, RV170, RV320). Caso queira-se transformar cilindros autónomos em cilindros acopláveis ao sistema, basta encomendar as conexões e tubos necessários e seguir as instruções específicas para cada série, publicadas no site www.specialsprings.com.

LASER MARKING

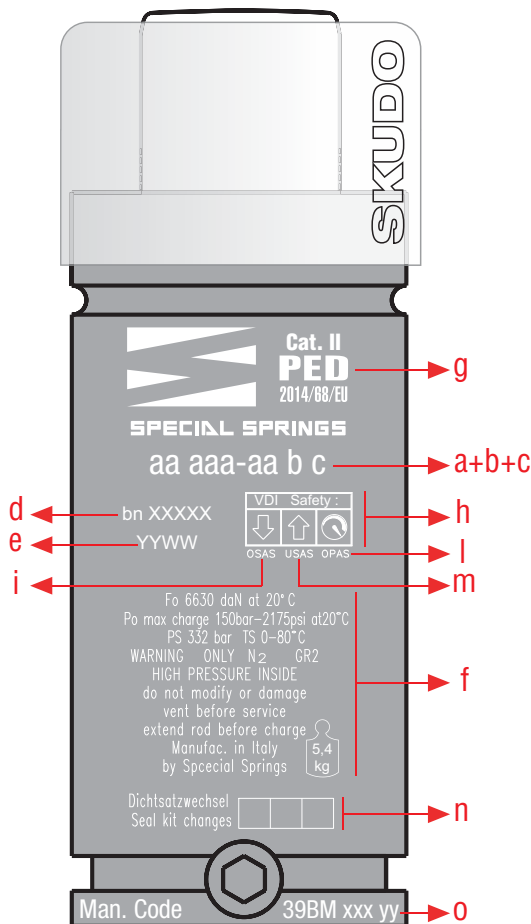

IT

- Codice modello
- Indice revisione
- Versione collegabile a sistema
- Lotto di produzione
- Data di produzione
- Info generali
- Categoria PED
- Pittogrammi sicurezza
- Sicurezza attiva oltre corsa
- Sicurezza attiva oltre pressione
- Sicurezza attiva ritorno incontrollato
- Numero cambi guarnizione
- Kit manutenzione

EN

- Model code
- Revision indicator
- Hosed-system version
- Batch number
- Production date
- General info
- PED Category
- Safety pictograms
- Over stroke active safety
- Over pressure active safety
- Uncontrolled speed active safety
- Number of seal replacements
- Maintenance kit

DE

- Modellcode
- Revisionsindex
- Version kann an das System angeschlossen werden
- Produktionsposten
- Herstellungsdatum
- Allgemeine Informationen
- PED Kategorie
- Sicherheitspiktogramme
- Aktiven überhubsicherung
- Aktive überdruck-sicherheitsvorrichtung
- Aktiver Schutz bei Unkontrolliertem Rückhub
- Anzahl der Dichtungswechsel
- Wartung set

FR

- Référence modèle
- N de révision
- Version pouvant être reliée à un système
- Lot de production
- Date de fabrication
- Information générales
- Catégorie PED
- Pictogrammes de sécurité
- Securite active outre-course
- Securite active outre-pression
- Securité Active pour Retour Incontrôlé
- Nombre de remplacements du joints
- Set manutention

ES

- Código de modelo
- Indicador de revisión
- Versión conectable a sistema
- Lote de producción
- Fecha de fabricación
- Información general
- Categoría PED
- Pictogramas de seguridad
- Seguridad activa de fin de carrera
- Seguridad activa ultra presión
- Seguridad Activa de Retorno Incontrolado
- Numero dos cambios de la junta
- Set mantenimiento

PT

- Código do modelo
- Índice de revisão
- Versão que pode ser ligada em sistema
- Lote de produção
- Data de produção
- Informações gerais
- Classe de risco PED
- Pictogramas de segurança
- Segurança ativa mecânica
- Segurança ativa sobrepressão
- Segurança para Retorno da Haste
- Número das substituições da vedação
- Manutenção de conjunto

IT Per tutti i modelli è indicata nel catalogo sia la forza finale isoteramica che politropica.

La forza finale isoteramica con 100% Cu, è un valore calcolato in condizioni statiche e può essere considerato sufficiente nell'uso normale dei cilindri.

La forza finale politropica con 100% Cu, è un valore più realistico quando il cilindro è in lavoro. Essendo però la temperatura del gas all'interno del cilindro non costante e dipendente da corsa nominale, corsa di lavoro, velocità della pressa, no. di cicli al minuto, volume del gas, temperatura dell'ambiente e di lavoro, etc. la forza finale politropica dovrebbe essere calcolata caso per caso.

Special Springs, comunque a titolo informativo, indica anche i valori approssimati di forza politropica calcolati a regime termico, 100% Cu, 30 SPM, velocità pressa costante e temperatura ambiente 20°C. Per maggiori informazioni contattare Special Springs.

EN For all models, both the isothermal and polytropic end force are indicated in the catalog.

The isothermal end force with 100% Cu, is a value calculated on static conditions and can be considered sufficient for a normal use of cylinders.

The Polytropic end force, with 100% Cu, is a more realistic value when the cylinder is working. Though, being the temperature of the gas inside the cylinder not constant, and depending from several factors, the Polytropic end force should be calculated case by case. The influencing factors are, for example: nominal stroke, working stroke, press speed, number of cycles per minutes, gas volume, working and environment temperature etc.

Special Springs, for user information, indicates the approximated values of polytropic force calculated at thermal regime, 100% Cu, ca 30 SPM constant press speed and room temperature at around 20°C. For further details please contact Special Springs.

DE In unserem Katalog ist für alle Gasdruckfedern sowohl die isotherme als auch die polytrope Endkraft angegeben.

Die isotherme Endkraft bei 100 % Cu ist ein Wert, der unter beinahe statischen Bedingungen ermittelt worden ist und der unter normalen Einsatzbedingungen der Gasdruckfeder als ausreichend genau betrachtet werden kann.

Die polytrope Endkraft bei 100 % Cu ist ein realistischer Wert wenn die Gasdruckfeder in Betrieb ist. Da jedoch die Temperatur des Stickstoffs im Inneren der Gasdruckfeder nicht konstant ist und abhängig ist vom Nominalhub, vom Arbeitshub, der Pressengeschwindigkeit, der Anzahl Zyklen pro Minute, dem Volumen des Stickstoffgases, der Raum- und Arbeitstemperatur, etc. müsste die polytrope Endkraft für jede Anwendung berechnet werden.

Special Springs gibt jedoch zur Information auch den annähernde Wert der polytropen Kraft an, der bei stabiler Betriebstemperatur, 100 % Cu, ca. 30 Hübe pro Minute, konstanter Pressengeschwindigkeit und ca. 20°C Raumtemperatur ermittelt worden ist. Für weitere Informationen wenden Sie sich bitte direkt an Special Springs.

FR Pour tous les modèles, on indique sur le catalogue, soit la force finale isothermique, que celle polytrophique.

La force finale isothermique, avec 100% de Cu, est une valeur calculée en conditions statiques et peut être considérée suffisante en l'usage normal des cylindres.

La force finale polytrophique, avec 100% de Cu, est une valeur plus réaliste lorsque le cylindre est en travail. Toutefois, étant donné que la température du gaz à l'intérieur du cylindre n'est pas constante et dépend de différents facteurs, tels que: course nominale, course de travail, vitesse de la presse, nombre de cycles par minute, volume du gaz, température de travail et de l'environnement etc., la force polytrophique finale doit être calculé au cas par cas.

Special Springs, cependant, à des buts d'information, indique aussi les valeurs approximés de la force polytrophique calculés au régime thermique, 100% Cu, environ. 30 SPM, presse à vitesse constante et température ambiante 20 °C. Pour tous renseignements complémentaires, contactez Special Springs.

ES Para todos los modelos, se indica en el catálogo, tanto la fuerza final isotérmica, como la politrópica.

La fuerza final isotérmica con 100% de Cu, es un valor calculado en condiciones estáticas y puede considerarse suficiente en el uso normal de los cilindros.

La fuerza politrópica finale con 100% de Cu, es un valor más realista cuando el cilindro está en trabajo. Dado que, sin embargo, la temperatura del gas dentro del cilindro no es constante y depende de varios factores, tales como: carrera nominal, la carrera de trabajo, la velocidad de la prensa, el número de ciclos por minuto, el volumen del gas, la temperatura del medio ambiente y trabajo, etc., la fuerza politrópica final debe calcularse caso por caso.

Special Springs, sin embargo, a título informativo, indica los valores aproximados de fuerza politrópica calculados a régimen térmico, 100% Cu, ca. 30 SPM, velocidad constante de prensas y temperatura ambiente a 20 °C. Para más informaciones póngase en contacto con Special Springs.

PT Para todos os modelos, é indicada no catálogo tanto a força final isotérmica, que a politrópica.

A força final isotérmica com 100% de Cu, é um valor calculado em condições estáticas e pode ser considerada suficiente, em utilização normal dos cilindros..

A força politrópica finale com 100% de Cu, é um valor mais realista quando o cilindro estiver em trabalho. Uma vez que, no entanto, a temperatura do gás no interior do cilindro não é constante e depende de vários factores, tais como: curso nominal, o curso de trabalho, a velocidade de impressão, o número de ciclos por minuto, o volume do gás, a temperatura do ambiente e trabalhar etc., o a força politrópica final deve ser calculado caso a caso.

Special Springs, no entanto, para fins de informação, indica os valores aproximados da força politrópica calculados a regime térmico 100% Cu, ca. 30 SPM, velocidade constante de prensas e temperatura ambiente a. 20 °C. Para mais informações contacte Special Springs.

F_{1i}
isothermal
end force

F_{1p}
Polytropic
end force



$$F_0 = P \cdot S$$

- IT** Per calcolare la forza iniziale (Fo) di un cilindro a gas è sufficiente moltiplicare la pressione di caricamento massima (P) per l'area di tenuta, stelo o pistone, della guarnizione (S).
- EN** To calculate the initial force of each gas cylinder, multiply the maximum charging pressure (P) to the area of sealing, rod or piston, of the gasket seal.
- DE** Zur Berechnung der Anfangskraft (Fo) einer Gasdruckfeder, muss der angegebene maximale Befülldruck (P) mit der von der Dichtung abgedichteten Fläche an der Kolbenstange oder Kolben (S) multipliziert werden.
- FR** Pour calculer la force initiale (Fo) d'un cylindre à gaz, il suffit de multiplier la pression maximum de chargement (P) pour la surface de retenue, tige ou piston, du joint (S).
- ES** Para calcular la fuerza inicial (Fo) de un cilindro de gas, se multiplica la presión máxima de carga (P) por el área de junta, vástago o pistón, de la guarnición(S).
- PT** Para calcular a força inicial (Fo) de um cilindro a gás, basta multiplicar a pressão de carga máxima (P) pela área de estanquidade do haste/pistão, da guarnição.

Isothermal force

Metric units

$$F_{x_i} = P \cdot S \cdot \left(\frac{1}{1 - \frac{S}{V_0} \cdot C_x} \right)^n$$

Imperial units

$$F_{x_i} = P \cdot S \cdot \left(\frac{1}{1 - \frac{S}{V_0} \cdot C_x} \right)^n$$

Tab. 1

P	n
≤100 bar	1,09
150 bar	1,19
200 bar	1,31

- IT** Per calcolare la forza intermedia isoterma (Fx_i) ad una determinata corsa di lavoro (Cx) applicare la formula sostituendo i relativi valori numerici. L'esponente (n) varia in funzione della pressione di caricamento (P) come indicato nella Tab.1. Per valori intermedi di pressione è possibile calcolare il valore di (n) proporzionalmente.
- EN** To calculate the intermediate isothermal force (Fx_i) to a specific working stroke (Cx), use the formula by replacing the relative numeric values. The exponent (n) varies in function of the charging pressure (P) as indicated in Tab.1. For intermediate pressure values, it is possible to calculate the (n) value proportionally.
- DE** Zur Berechnung der isothermischen Zwischenkraft (Fx_i) bei einem bestimmten Arbeitshub (Cx) verwenden Sie die nebenstehende Formel und setzen Sie entsprechend die im Katalog angegebenen Werte ein. Der Exponent (n) ist abhängig von dem Befülldruck (P). Mit Hilfe der Angaben in der Tab.1 können Zwischenwerte des Druckes proportional berechnet werden.
- FR** Pour calculer la force intermédiaire isothermique (Fx_i) d'un ressort à gaz à une course de travail saisie (Cx), vous devez utiliser cette formule en substituant les chiffres relatifs aux valeurs numériques. L'Exposant (n) varie en fonction de la pression de chargement (P), comme montré dans le Tab.1. Pour les valeurs intermédiaires de pression, il est possible de calculer la valeur (n) de façon proportionnelle.
- ES** Para calcular la fuerza isoterma intermedia (Fx_i) para una carrera de trabajo determinada (Cx) aplicar la fórmula mediante la sustitución de los valores numéricos correspondientes. El exponente (n) varia en función de la presión de carga (P) como se muestra en Tab.1. Para valores intermedios de presión, es posible calcular el valor de (n) de manera proporcional.
- PT** Para calcular a força isotérmica intermediária (Fx_i) para um determinado curso de trabalho (Cx) aplicar a fórmula através da substituição dos valores numéricos relevantes. O expoente (n) varia em função da pressão de carga (P), como mostrado na Tab.1. Para os valores intermédios de pressão, é possível calcular o valor de (N) proporcionalmente.

Polytropic force

Metric units

$$F_{x_p} = P \cdot S \cdot \left(\frac{1}{1 - \frac{S}{V_0} \cdot C_x} \right)^{1,58}$$

Imperial units

$$F_{x_p} = P \cdot S \cdot \left(\frac{1}{1 - \frac{S}{V_0} \cdot C_x} \right)^{1,58}$$

- IT** Per calcolare un valore approssimato di forza intermedia politropica (Fx_p) ad una determinata corsa di lavoro (Cx) applicare la formula sostituendo i relativi valori numerici. L'esponente (n) per la forza politropica può essere assunto pari a 1,58 per la maggior parte delle normali applicazioni.
- EN** To calculate the approximated value of polytropic intermediate force (Fx_p) to a specific working stroke (Cx), use the formula by replacing the relative numeric values. The exponent (n) for the polytropic force shall be assumed to be equal to 1,58 for the majority of normal applications
- DE** Zur Berechnung der ungefähren polytropischen Zwischenkraft (Fx_p) bei einem bestimmten Arbeitshub (Cx) verwenden Sie die nebenstehende Formel und setzen Sie entsprechend die im Katalog angegebenen Werte ein. Der Exponent (n) beträgt im Normalfall 1,58.
- FR** Pour calculer la valeur de force polytrophique intermédiaire (Fx_p) d'un ressort à gaz à une course de travail saisie (Cx), vous devez utiliser cette formule en substituant les chiffres relatifs aux valeurs numériques. L'Exposant (n) peut être assumé comme 1,58 pour la majorité d'utilisations courantes.
- ES** Para calcular un valor aproximado de la fuerza intermedia politrópica (Fx_p) para una carrera de trabajo determinada (Cx), aplicar la fórmula mediante la sustitución de los valores numéricos correspondientes. El exponente (n) para la fuerza de politrópico puede suponerse como igual a 1,58 para la mayoría de las aplicaciones normales.
- PT** Para calcular um valor aproximado da força intermediária politrópica (Fx_p) para um determinado curso de trabalho (Cx), aplicar a fórmula através da substituição dos valores numéricos relevantes. O expoente (n) para a força politrópica pode ser assumido como sendo igual a 1,58 para a maioria das aplicações normais.

$$P_n = \frac{F_n}{S}$$

- IT** Per determinare la pressione di caricamento necessaria per ottenere una forza (Fn) diversa dalla nominale (Fo) è sufficiente dividere la forza richiesta (Fn) per l'area di tenuta, stelo o pistone, della guarnizione.
- EN** To determine the pressure level required to achieve a force (Fn) different from the nominal one (Fo), divide the required force (Fn) by the area of sealing, rod or piston, of the gasket seal.
- DE** Zur Berechnung des benötigten Befülldruckes (Pn) für eine spezifische Anfangskraft (Fn), die von der im Katalog angegebenen Anfangskraft abweicht, muss die gewünschte Anfangskraft (Fn) durch die von der Dichtung abgedichteten Fläche an der Kolbenstange oder Kolben dividiert werden.
- FR** Pour calculer la pression de chargement nécessaire pour obtenir une force (Fn) différente de la force nominale (Fo) il suffit de diviser la force requise (Fn) par la surface d'étanchéité (tige ou piston) du joint.
- ES** Para calcular la presión de carga necesaria a fin de obtener una fuerza (Fn) distinta de la nominal (Fo), se divide la fuerza pedida (Fn) por el área de estanquidad, vástago o pistón, de la guarnición.
- PT** Para determinar a pressão de carga necessária para obter uma força (Fn) diferente da nominal (Fo), basta dividir a força necessária (Fn) pela área de estanquidade do embolo/pistão, da guarnição.

Max Speed SPM ↓ Strokes per Minute

- IT** Non superare la velocità massima dello stelo indicata. Velocità superiori possono ridurre la durata dei cilindri.
- EN** Do not exceed the maximum rod speed indicated. Exceeding speeds can reduce the cylinder's life.
- DE** Die angegebene max. Geschwindigkeit der Kolbenstange darf nicht überschritten werden. Höhere Geschwindigkeiten können die Lebensdauer der Gasdruckfedern reduzieren.
- FR** Ne pas excéder la vitesse maximale de la tige indiquée pour chaque modèle. Vitesses supérieures a peuvent réduire la durée des vérins.
- ES** No exceder la velocidad máxima del vástago indicada para cada modelo. Velocidades mas altas pueden reducir la duracion del cilindro.
- PT** Não exceda a velocidade máxima da haste indicada para cada modelo. Velocidades mais elevadas podem reduzir a vida útil do cilindro.

- IT** Per ogni modello è indicato il campo di frequenza massima di utilizzo raccomandata al 100% Cu. Il valore inferiore è riferito alla corsa più lunga, quello superiore alla corsa più breve. Frequenze superiori possono ridurre la durata dei cilindri.
- EN** The maximum frequency range of use recommended to 100 % Cu is indicated for every model. The lower value is referred to the longer stroke, the higher value refers to the shorter stroke. Higher frequencies can reduce the cylinder duration.
- DE** Für jeden Typ ist eine empfohlene max. Hubzahl (SPM) unter Berücksichtigung des max. Hubes (Cu) angegeben. Der kleine Wert bezieht sich auf den größten auswählbaren Hub, während der größere Wert sich auf den kleinsten auswählbaren Hub bezieht. Höhere Hubzahlen reduzieren die Lebensdauer der Gasdruckfedern.
- FR** Pour chaque modèle, on indique le champ de fréquence maximale d'usage recommandé au 100% de Cu. La valeur inférieure se réfère à la course plus longue, tandis que la valeur inférieure à la course plus courte. Fréquences supérieures peuvent réduire la durée des vérins.
- ES** Para cada modelo, se indica el rango frecuencia máxima de uso recomendada al 100%. El valor inferior indicado es válido para carrera mas larga, mientras que el valor superior se refiere a carrera mas corta.. frecuencias más altas pueden reducir la duración de los cilindros.
- PT** Para cada modelo se indica o intervalo de frequência máxima do uso recomendada al 100% Cu. O valor mais baixo é relatado para o curso mais longo, o mais elevado para o curso mais curto. frequências mais elevadas podem reduzir a duração dos cilindros.

LIFE WARRANTY

- IT** Se correttamente installati e in normali condizioni di lavoro, i cilindri ad azoto Special Springs sono garantiti per una durata di **200.000 metri lineari** di corsa. Condizioni di lavoro critiche o cause esterne che provochino mal funzionamento possono ridurre, anche significativamente, la durata. La garanzia è valida per la durata indicata entro **2 anni** dalla data di acquisto. Utilizzi difformi dalle prescrizioni e dalle linee guida specificate e fornite con i prodotti o danni meccanici saranno causa di immediata decadenza della garanzia.
Termini legali di garanzia su www.specialsprings.com
- EN** If correctly installed and under normal working conditions, Special Springs nitrogen cylinders can guarantee a life of **200.000 linear meters** of stroke. Heavy working conditions or external causes that would cause malfunctioning may reduce the life significantly. The warranty is valid for the indicated life within **2 years** from the purchase date. Warranty will not be applied to mechanical damages or damages caused by negligence, misuse and noncompliance with the warning and indications contained in the instruction sheet.
Warranty legal terms on www.specialsprings.com
- DE** Bei korrektem Einbau und unter normalen Betriebsbedingungen, ist für die Special Springs Gasdruckfedern eine Lebensdauer von 200.000 m Gesamthub gewährleistet. Kritische Betriebsbedingungen oder äußere Einflüsse, die zu Störungen führen, können die Lebensdauer wesentlich verringern. Die Garantie gilt für die angegebene Dauer innerhalb von zwei Jahren ab Kaufdatum. Die Garantie erlischt mit sofortiger Wirkung bei von den Vorschriften und Richtlinien, die zusammen mit den Produkten geliefert werden, abweichendem Einsatz bzw. mechanischer Beschädigung.
Garantiebedingungen siehe www.specialsprings.com
- FR** Si correctement installées et avec des normales conditions d'usage, les ressorts à l'azote Special Spring sont garantis pour une durée de **200.000 mètres linéaires** des course. Des conditions de travail critiques ou d'autres cause externes qui provoquent des mal fonctionnements pourraient réduire, même significativement, la durée. La garantie est valable pour la durée indiquée entre **2 ans** de la date d'achat. Des utilisations différentes des prescriptions des lignes-guide spécifiées et fournies avec les produits, ou encore des endommagements mécaniques causeront l'immédiate décadence de la garantie.
Termes juridiques de garantie sur www.specialsprings.com
- ES** Con una instalación correcta y en condiciones normales de trabajo, los cilindros resorte de nitrógeno de Special Springs están garantizados para una duración de **200.000 metros lineales** de carrera. Condiciones de trabajo críticas o causas externas que provoquen funcionamiento incorrectos pueden reducir, incluso de manera significativa, la vida útil. La garantía es válida para la duración indicada, máximo **2 años** desde fecha de compra. Usos diferentes a los prescritos y a las líneas guía especificadas y suministradas con el producto o daños mecánicos serán causa inmediata de cadencia de la garantía.
Términos legales de garantía en www.specialsprings.com
- PT** Se correctamente instalados e em condições normais de trabalho, os cilindros de nitrogênio Special Springs podem garantir uma duração de **200.000 metros lineares** de curso. Condições críticas ou causas externas que possam causar mau funcionamento de trabalho pode reduzir a duração de uma forma significativa. A garantia é válida durante o período indicado dentro de **2 anos** até a data de compra. Ou qualquer uso diferente respeito das prescrições e orientações fornecidas e especificada com os produtos, ou danos mecânicos causaria a decadência garantia imediata.
Termos legais de garantia em www.specialsprings.com



IT TUTTI i cilindri ad azoto SPECIAL SPRINGS soddisfano i requisiti previsti dalla Direttiva Europea sulle attrezzature a pressione 2014/68/EU, che si applica nell'Unione Europea dal 19 Luglio 2016. Questa Direttiva regola e definisce come attrezzature a pressione i recipienti, le tubazioni e gli accessori sottoposti a una pressione massima ammissibile PS superiore a 0,5 bar. Più specificatamente, la Direttiva 2014/68/EU prevede la classificazione in categorie e l'obbligo di marcatura CE con il numero identificativo del produttore per le attrezzature il cui risultato della pressione P (bar) x il volume del fluido V_0 (dm³) sia pari o superiore a 50. La marcatura CE è obbligatoria per le Categorie II e III, ma facoltativa per la Categoria I. Per tutti i cilindri a gas il cui prodotto $P \times V_0$ è inferiore a 50 si applica l'Articolo 4.3 della Direttiva e non sono marcati CE.

EN ALL Special Springs nitrogen cylinders fulfill the requirements of the European directive concerning pressure equipment (2014/68/EU), applied in the European Union from 19th July 2016. This directive sets out the standards for pressure equipment and defines them as vessels, piping and accessories subject to a maximum allowable pressure PS greater than 0,5 bar. In particular, according to the directive 2014/68/EU, pressure equipments are classified by category and they shall bear the CE marking with the identification number of the manufacturer when the result of pressure P (bar) X fluid volume V_0 (dm³) is 50 or more. The CE marking is mandatory for Categories II and III, but discretionary for Category I. All gas cylinders which result of $P \times V_0$ is less than 50 are subject to Article 4.3 of the same directive and they do not bear the CE marking.

DE Alle Stickstoff-Gasdruckfedern von Special Springs erfüllen die Forderungen der ab dem 19. Juli 2016 in der Europäischen Union anzuwendenden Richtlinie 2014/68/EU über die Druckgeräte. Diese Richtlinie legt die Anforderungen an die Druckgeräte fest und definiert diese als Behälter, Rohrleitungen und Ausrüstungsteile mit einem max. zulässigen inneren Überdruck (PS) von mehr als 0,5 bar. Im Einzelnen werden Druckgeräte gemäß der Richtlinie 2014/68/EU in Kategorien eingestuft und müssen mit der CE-Kennzeichnung und der Identifikationsnummer des Herstellers beschriftet werden, wenn der errechnete Wert des Produktes von Druck (P) multipliziert mit dem Befüllungsvolumen V_0 (dm³) größer als 50 ist. Die CE-Kennzeichnung ist für die Kategorien II und III zwingend, jedoch nicht für die Kategorie I. Die Gasdruckfedern, bei denen der errechnete Wert des Produktes von Druck (P) multipliziert mit dem Befüllungsvolumen V_0 (dm³) kleiner als 50 ist, tragen gemäß dem Artikel 4.3 der genannten Richtlinie keine CE-Kennzeichnung.

FR TOUS les cylindres-ressorts à l'azote de SPECIAL SPRINGS satisfont aux prescriptions de la Directive Européenne sur les équipements sous pression 2014/68/EU, qui s'applique dans l'Union Européenne à partir du 19 juillet 2016. Cette Directive fixe les exigences envers les équipements sous pression et les définit comme les récipients, les tuyauteries et les accessoires soumis à une pression maximale admissible PS supérieure à 0,5 bar. Plus spécifiquement, la Directive 2014/68/EU prévoit la classification en catégories et l'obligation du marquage CE avec le numéro d'identification du fabricant pour les équipements dont le résultat de la pression P (bar) X le volume du fluide V_0 (dm³) est de 50 ou plus. Le marquage CE est obligatoire pour les catégories II et III, mais facultatif pour la catégorie I. Tous les cylindres-ressorts à l'azote dont le produit de $P \times V_0$ est moins de 50 sont réglementés par l'article 4.3 de la même directive et ne portent pas le marquage CE.

ES TODOS los cilindros de nitrógeno SPECIAL SPRINGS cumplen con los requerimientos de la Directiva Europea sobre los equipos a presión 2014/68/EU, que se aplica en toda la Unión Europea a partir del 19 de julio de 2016. Esta Directiva reglamenta y define como equipos a presión los recipientes, las tuberías y los accesorios sometidos a una presión máxima admisible PS superior a 0,5 bar. Más concretamente, la directiva 2014/68/EU prevé la clasificación en categorías y la obligación del marcado CE con el número identificativo del fabricante para los equipos cuyo resultado de la presión P (bar) x el volumen del fluido V_0 (dm³) sea de 50 o más. El marcado CE es obligatorio para las categorías II y III, pero facultativa para la categoría I. Todos los cilindros de nitrógeno cuyo resultado $P \times V$ es menor de 50 están sujetos al artículo 4.3 de la directiva y no llevan el marcado CE.

PT TODOS os cilindros de nitrogénio Special Springs satisfazem os requisitos da Diretiva Europeia para equipamentos sob pressão 2014/68/EU, que se aplica na União Europeia a partir de 19 de julho de 2016. Esa Diretiva regulamenta os equipamentos sob pressão e os define como os recipientes, os tubagens e os acessórios sujeitos a uma pressão máxima admissível PS superior a 0,5 bar. Em particular, a directiva 2014/68/EU prevê a classificação em categorias e a obrigação da marcação CE com o número de identificação do fabricante para os equipamentos cujo o resultado de pressão P (bar) X volume fluido V_0 (dm³) é igual ou superior a 50. A marcação CE é obrigatória para as categorias II e III, mas discricionária para a categoria I. Todos os cilindros de nitrogénio, através da qual resultam $P \times V_0$ é inferior a 50 estão sujeitos ao artigo 4.3 da mesma directiva e não ostentam a marcação CE.

CE
PED
2014/68/EU

IT Qualora, dopo un lungo funzionamento o per applicazioni particolarmente gravose, si verificassero delle perdite di pressione, significa che le tenute hanno iniziato ad usurarsi o sono state danneggiate. E' quindi possibile, con l'uso di appositi utensili e kits ed il supporto di specifici video e dettagliate istruzioni, ripristinare le condizioni originarie di tenuta e guida. Solo personale qualificato dovrebbe eseguire la manutenzione. Eventuali errori possono essere causa di gravi rischi per la sicurezza o limitare la durata dei cilindri. Prima di eseguire qualsiasi intervento scaricare completamente la pressione e assicurare che lo stelo sia completamente compresso nel corpo.

EN If pressure losses occur after extended use or particularly heavy applications, this indicates that the sealing gaskets are worn or damaged. Using special tools and kits, and with the support of videos and detailed instructions, it is possible to restore the original seal and guide conditions. Maintenance must only be conducted by qualified personnel. Errors would cause serious injury or reduce the working life of the cylinders. Before carrying out any work on the system, fully exhaust all pressure and ensure that the rod is fully retracted into the body.

DE Wird nach langer Betriebstätigkeit oder besonders beanspruchender Verwendung ein Druckverlust festgestellt, bedeutet dies, dass die Dichtungen allmählich abgenutzt sind oder beschädigt wurden. Es ist mit Hilfe von zweckmäßigem Werkzeug oder Sets sowie spezifischen Videos und detaillierten Anweisungen möglich, die Ausgangsbedingungen von Dichtung und Führung wiederherzustellen. Die Wartung sollte nur von qualifiziertem Personal vorgenommen werden. Etwaige Fehler können schwerwiegende Sicherheitsrisiken hervorrufen oder die Lebensdauer der Zylinder einschränken. Entladen Sie den Druck und stellen Sie sicher, dass der Schaft komplett in den Körper eingeführt ist, bevor Sie Eingriffe vornehmen.

FR Si des pertes de pression se produisent après un long fonctionnement ou avec des applications particulièrement lourdes, cela signifie que les joints de retenue ont commencé à s'usurer ou qu'ils sont endommagés. L'utilisation d'outils et de kits appropriés, ainsi que le support de vidéos spécifiques et d'instructions détaillées permettront de rétablir les conditions d'origine de retenue et de guidage. La maintenance doit être effectuée uniquement par du personnel qualifié. Les éventuelles erreurs peuvent engendrer de graves risques pour la sécurité ou limiter la durée de vie des cylindres. Avant d'effectuer toute opération, décharger complètement la pression et s'assurer que la tige soit complètement comprimée dans le corps.

ES Si, después de mucho tiempo funcionando, o en caso de aplicaciones muy pesadas, se produjesen pérdidas de presión, significa que las guarniciones han comenzado a desgastarse o han sufrido algún desperfecto. En esos casos es perfectamente posible restablecer las condiciones originales de la guarnición o la guía mediante kits de herramientas especiales y vídeos de instrucciones específicas. El mantenimiento debe ser efectuado única y exclusivamente por personal cualificado. Cualquier error podría causar graves riesgos de seguridad o limitar la vida útil de los cilindros. Antes de cualquier reparación, descargar completamente la presión y asegurarse de que el vástago quede completamente

PT No caso em que, após um longo funcionamento ou por aplicações particularmente gravosas, se verificarem perdas de pressão, isso significa que os vedantes começaram a desgastar-se ou foram danificadas. Portanto, com a utilização dos utensílios e dos conjuntos, com o apoio de vídeos específicos e de instruções detalhadas é possível restabelecer as condições originais de estanquidade e guiamento. A manutenção só deve ser executada por pessoal qualificado. Erros eventuais podem ser a causa de riscos graves para a segurança ou limitar a duração dos cilindros. Antes de executar qualquer intervenção, descarregar completamente a pressão e assegurar-se de que o embolo recolhido.

Download step-by-step guide instructions at: <http://www.specialsprings.com>

IT Come previsto dalle linee guida della direttiva PED 2014/68/EU l'azienda che provvede alla manutenzione dei cilindri marchiati CE dal fabbricante (P x Vo \geq 50) si assume la completa responsabilità di far riesaminare gli stessi da un ente di certificazione accreditato. Diversamente tali manutenzioni potranno essere effettuate esclusivamente da Special Springs.

EN As prescribed by the guidelines of PED 2014/68/EU, the company taking care of the maintenance for cylinders laser marked CE by the producer (P x Vo \geq 50), must get them checked by a certified body. Otherwise, the maintenance can be carried out exclusively by Special Springs.

DE Wie in der Richtlinie PED 2014/68/EU vorgeschrieben übernimmt die Firma, die die Instandhaltung von Gasdruckfedern durchführt, die vom Hersteller mit CE-Kennzeichnung versehen worden sind (P x Vo \geq 50), die volle Verantwortung dafür, diese von einer zugelassenen Zertifizierungsanstalt nachprüfen zu lassen. Andernfalls können diese Instandhaltungsarbeiten ausschließlich von Special Springs durchgeführt werden.

FR Selon le mode prévu par les indications de la directive PED 2014/68/EU, l'entreprise qui s'occupe de l'entretien des cylindres marqués CE par le producteur (P x Vo \geq 50), assume la responsabilité de les faire réexaminer par un institut de certification qualifié. Autrement, les entretiens peuvent être effectués exclusivement par Special Springs.

ES Como las indicaciones de la directiva PED 2014/68/EU estipulan, la empresa que provee al mantenimiento de los cilindros grabado CE por el productor (P x Vo \geq 50), se hace cargo de que una empresa certificada y capacitada les controle. De otra manera los mantenimientos pueden ser llevado exclusivamente por Special Springs.

PT De acordo com as directrizes PED 2014/68/EU a fabrica que fornece a manutenção dos cilindros com a marca CE do fabricante (P x Vo \geq 50) assume a responsabilidade de reexaminar os mesmos por uma entidade de certificação creditada. De outra forma tais manutenções poderão ser efectuadas exclusivamente pela Special Springs.



PED
2014/68/EU





How to Order



Maintenance kits

- IT** Se il codice Man. Code non è riportato sul cilindro: 39BM + Codice cilindro completo.
- EN** If Man. Code is not indicated on the cylinder, order: 39BM + complete Part Number.
- DE** Wenn Man. Code auf der Gasdruckfeder nicht vorhanden, bestellen Sie 39BM + vollständige Artikelnummer.
- FR** Si le Man. Code n'est pas indiqué en le cylindre, ordonnez 39BM + Numéro d'Article complet.
- ES** Si el Man. Código no está indicado en el cilindro, ordenar 39BM + Código completo del Producto.
- PT** Se a referencia Man Code não estiver escrita no cilindro, favor solicitar 39BM + Código do Produto completo.

EXAMPLE: 39BMRV6600-050 A

- IT** Se presente nel cilindro, riportare il codice Man. Code in fase di ordinazione.
- EN** If Man. Code is indicated on the cylinder, specify it on the order.
- DE** Wenn Man. Code auf der Gasdruckfeder vorhanden, bitte in der Bestellung angeben.
- FR** Si le Man. Code est indiqué en le cylindre, précisez-le dans l'ordre.
- ES** Si el Man. Code está indicado en el cilindro, especificarlo en el orden.
- PT** Se indicado no cilindro, indique o Man. Code na ordem.

EXAMPLE: 39BMRV06600C



- IT** Kit include: Boccola assemblata, Valvola unidirezionale, lubrificante e grasso, Istruzioni di montaggio.
- EN** Kit contains: Assembled bushing, one way valve, lubricant and grease, instructions sheet.
- DE** Das Set beinhaltet: montierte Buchse, Rückschlagventil, Schmieröl und Schmierfett, Montageanleitung.
- FR** Leditcomprend: Douilleassemblée, Soupape à sens unique, lubrifiant et graisse, Instructions pour le montage.
- ES** El Kit contiene: casquillo ensamblado, Válvula unidireccional, lubricante y grasa, Instrucciones de montaje.
- PT** O Kit contém: Bucha ensamblada, Válvula unidireccional, lubrificante e graxa, Instruções de montagem.



- IT** Per una maggiore sicurezza di utilizzo, consegnare sempre i fogli di istruzioni e uso allegati ai cilindri e agli accessori Special Springs insieme alle attrezzature.
- EN** For a safer use, always provide all tools together with the instruction sheets included with Special Springs cylinders and accessories.
- DE** Für eine sicherere Verwendung, bitte liefern Sie immer zusammen mit dem Werkzeug die Betriebsanleitung, die den Gasdruckfedern und Zubehörteile von Special Springs beiliegt, mit.
- FR** Pour une majeure sécurité d'utilisation, veuillez fournir toujours avec les outils la fiche d'instructions livrée avec les ressorts gaz et les accessoires de Special Springs.
- ES** Para una utilización más segura, por favor entregue siempre todas las herramientas con la hoja de instrucciones suministrada con los cilindros de nitrógeno y los accesorios de Special Springs.
- PT** Para uma utilização mais segura, por favor entregue sempre todas as ferramentas com a folha de instruções fornecida com os cilindros e os acessórios de Special Springs.

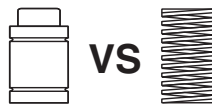

BENEFITS

RESULT

Less Space

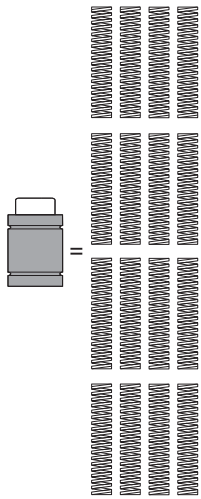

Notevole riduzione della superficie, dello spazio in altezza e del volume occupato. Eliminazione dispositivi di precarico e guidaggio.

Considerable reduction of the required surface, height and volume. No need for retaining and pre-load devices.

Deutliche Reduzierung des Platzbedarfs. Vorrichtungen zum Vorspannen und Führen werden nicht benötigt

Réduction importante de la surface, de la hauteur et du volume occupés. Élimination de dispositifs de pré-charge et guidage.

Notable reducción de la superficie, de la altura y del volumen ocupados. Eliminación de dispositivos de precarga y guía.

Redução notável da superfície, da altura e do volume ocupados. Eliminação de dispositivos de pré-carga e guidamento.

Lower Height

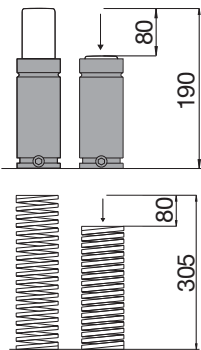

Notevole riduzione degli ingombri in altezza a parità di forza e corsa. Costruzione dello stampo più compatta.

Considerable height reduction for the same working deflection and force. Compact tool construction.

Wesentliche Reduzierung des Höhenbedarfs bei gleichem Hub und gleicher Kraft. Kompaktere Werkzeugkonstruktion.

Réduction importante des encombrements en hauteur avec une course et une force équivalente. Construction plus compacte du moule.

Notable reducción de la altura con igual fuerza y carrera. Construcción más compacta del molde.

Redução notável em altura com igual força e curso. Construção mais compacta da Ferramenta.

Save Money

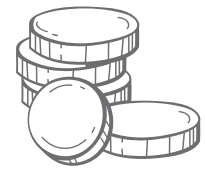

Controlled Force

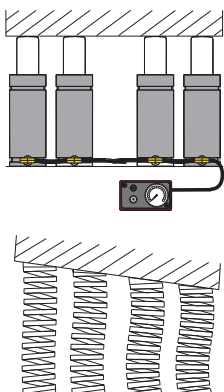

Forza bilanciata e posizionata dove richiesto. Visualizzazione continua della pressione e costante qualità dei pezzi stampati. Maggiore durata degli utensili.

The force is balanced and positioned where required. Pressure is always visible and quality of molded parts is constant. Longer life for tools.

Die Kraft ist stets ausgeglichen und positionierbar an den erforderlichen Stellen. Ständige Anzeige des Betriebsdrucks und konstante Qualität der zu fertigenden Teile. Längere Lebensdauer der Werkzeuge.

La force est équilibrée et positionnée là où elle est exigée. Visualisation continue de la pression et qualité constante des pièces moulées. Durée de vie majeure des outils.

Fuerza equilibrada y posicionable donde se precisa. Visualización continua de la presión y calidad constante de las piezas moldeadas. Mayor duración de las herramientas.

Força equilibrada e posicionável onde é necessária. Visualização contínua da pressão e constante qualidade das peças estampadas. Maior duração das ferramentas.

BENEFITS

RESULT

Large initial Forces

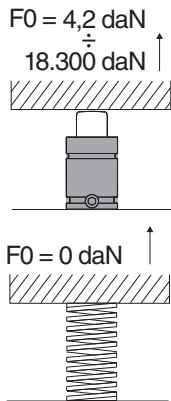

Nessun precarico e maggiore facilità di applicazione
No pre-loading needed. Easier and quicker fitting.
Einfacher Einbau, da externe Vorspannung nicht benötigt wird
Elimination de la pré-charge et application plus facile.
Eliminación de la precarga y mayor facilidad de aplicación.
Eliminação da pré-carga e maior facilidade de aplicação.

Almost Constant

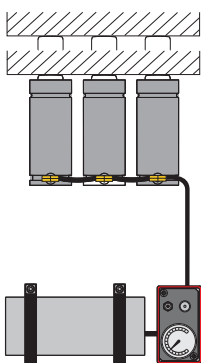

Migliore controllo e riduzione dell'incremento della forza. Migliore qualità dei pezzi stampati e minori scarti di produzione.
Better control and reduction of force increase. Better quality of molded parts and lower rejection rate in production.
Bessere Kontrolle und Reduzierung der Krafterhöhung. Bessere Qualität der fertigen Werkstücke und weniger Ausschuss bei der Produktion.
Meilleur contrôle et réduction de l'augmentation de la force. Une meilleure qualité des pièces moulées et une quantité inférieure de pièces rejetées en production.
Mejor control y reducción del aumento de la fuerza. Mejor calidad de las piezas moldeadas y menos piezas rechazadas en producción.
Melhor controlo e redução do incremento da força. Melhor qualidade das peças estampadas e menos peças rejeitadas na produção.

Save Money

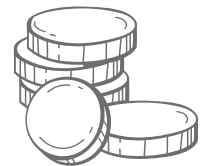

Adjustable Forces

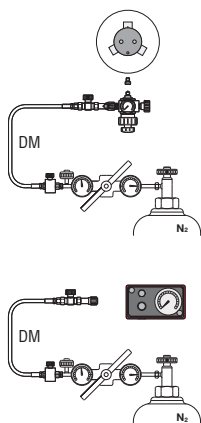

Forze regolabili e flessibilità d'uso.
Adjustable forces and flexible use.
Einstellbare Kräfte und flexibler Einsatz.
Forces réglables et flexibilité d'utilisation.
Fuerzas regulables y flexibilidad de utilización.
Forças reguláveis e flexibilidade de utilização.

HOW TO READ THE CATALOG



SAMPLE PAGE

1

2

SC 150	ISO 11901 - 1 B8 3180 220 000 001(MB)	VDI 3003 E24.54.815.G (PSA)	075.90.55 (FCA) EM24.54.700 (Renault)	B2 4006 (BMW) 39D 878 (VW)	
---------------	--	--------------------------------	--	-------------------------------	--

4

OSAS + OSM =

OVER STROKE
ACTIVE SAFETY

OVER STROKE
+ STROKE
SAFETY MARKER

ACTIVE SAFETY

OSAS MANIFOLD

p. 211

* F_{1i} =

Isothermal
end force
at 100% Cu

p. 16

** F_{1p} =

Polytrophic
end force
at 100% Cu

3

A

p. 114

5

7

8

9

10

11

12

6		°F 32 - 176	°C 0 - 80	ΔP ± 0,33 %/°C	P max 150 bar 2175 psi	P min 20 bar 290 psi	S 1,13 cm ² 0.175 in ²	SPM ~ 80 - 100 (at 20°C)	Max Speed 1,8 m/s	Maintenance kit 39BMS00150E
----------	--	----------------------	--------------------	-------------------	------------------------------	----------------------------	--	--------------------------------	----------------------	--------------------------------

13

14

15

16

17

CODE	Cu		L		L min		F ₀		F _{1i} *		F _{1p} **		V ₀		PED 2014/88/EU		
	mm	inch	mm	inch	mm	inch	daN	lb	daN	lb	daN	lb	cm ³	in ³		-Kg	-lb
SC 150 - 010 - D	10	0.39	70	2.76	60	2.36	170 ± 5% 150 bar 2175 psi + 20 °C +68 °F	382	191	429	207	466	12,0	0.73	0,28	0,62	✓
SC 150 - 013 - D	12,7	0,51	75,4	2,97	62,7	2,47			194	435	212	476	14,0	0,85	0,29	0,64	✓
SC 150 - 016 - D	16	0,63	82	3,23	66	2,60			197	442	216	486	16,0	0,98	0,30	0,66	✓
SC 150 - 025 - D	25	0,98	100	3,94	75	2,95			202	455	224	504	21,0	1,28	0,33	0,73	✓
SC 150 - 038 - D	38	1,50	126	4,96	88	3,46			207	465	231	519	28,0	1,71	0,36	0,79	✓
SC 150 - 050 - D	50	1,97	150	5,91	100	3,94			209	471	235	528	35,0	2,14	0,40	0,88	✓
SC 150 - 063 - D	63,5	2,48	177	6,97	113,5	4,47			211	475	238	535	43,0	2,62	0,44	0,97	✓
SC 150 - 080 - D	80	3,15	210	8,27	130	5,12			213	479	240	540	52,0	3,17	0,49	1,08	✓
SC 150 - 100 - D	100	3,94	250	9,84	150	5,91			214	482	242	545	63,0	3,84	0,55	1,21	✓
SC 150 - 125 - D	125	4,92	300	11,81	175	6,89			216	485	244	549	78,0	4,76	0,64	1,41	✓

19

18

HOW TO ORDER

(10 pcs) SC 150-050-D
 (10 pcs) SC 150-050-D-N

20

116 - 017
 Special Springs

<p>1 Modello di cilindro ad azoto Gas spring model Gasdruckfeder Modell Modèle de Ressorts Gaz Modelo de cilindro de nitrógeno Modelo de cilindro de nitrogênio</p>	<p>2 Standard internazionali / costruttori auto (ISO, VDI, ecc.) International / Automotive Standards (ISO, VDI, ecc.) Internationale / Automobil-Standards (ISO, VDI, ecc.) Standards internationaux / automobiles (ISO, VDI, ecc.) Estándares internacionales / automóvil (ISO, VDI, ecc.) Padrões internacionais / automóvel (ISO, VDI, ecc.)</p>		
<p>3 Modifica rispetto al catalogo precedente > see page 2 Modification respect to the former catalog > see page 2 Modification restet au catalogue précédent > voir page 2 Veränderungen gegenüber den alte Katalog > Siehe Seite 2 Cambios en comparación con el catálogo anterior > ver página 2 Alterações em comparação com o catálogo anterior > ver página 2</p>	<p>4 Raschiatore secondario applicabile Secondary Wiper can be mounted Sekundärabstreifer montierbar Joint racleur secondaire peut être monté Rascador secundario montable Raspador secundário montável</p>		
<p>5 Dispositivi di sicurezza presenti nel modello Safety devices provided on the model Anwesende Sicherheitseinrichtungen am Modell. Dispositifs de sécurités présents sur le modèle. Dispositivos de seguridad disponibles en el modelo. Dispositivos de segurança disponíveis no modelo.</p>	<p>6 Gas di caricamento Pressure medium Druckgas Gaz de chargement Gas de carga Gás de carga</p>		
<p>7 Temperatura di esercizio Working temperature Betriebstemperatur Température de fonctionnement Temperatura de funcionamiento Temperatura de funcionamento</p>	<p>8 $\Delta P / \Delta t$</p>		
<p>9 Pressione max di caricamento Max charging pressure Maximaler Ladedruck Pression de chargement maximum Presión máx de carga Pressão máxima de carga</p>	<p>10 Pressione min. di caricamento Min charging pressure Minimaler Ladedruck Pression de chargement minimum Presión mín de carga Pressão mínima de carga</p>		
<p>11 Area di tenuta stelo/pistone Rod/piston seal area Dichtungsbereich Kolbenstange/Kolben Zone d'étanchéité tige/piston Área de estanqueidad vástago/pistón Área de estanquidade do embolo/pistão</p>	<p>12 Cicli / minuto Strokes / minute Hube / Minute Cycles / minute Cyclos / minuto Pancadas / minuto</p>	<p>13 Codice Code Bestell-Nummer Référence Código Codigo</p>	
<p>14 Forza iniziale a 20°C Initial force at 20°C Ausgangsleistung bei 20°C Force initiale a 20°C Fuerza inicial a 20°C Força inicial a 20°C</p>	<p>15 Forza finale isoterma Isothermal end force Isothermische Endfestigkeit Force finale isothermique fuerza finale isotérmica força final isotérmica</p>		
<p>16 Forza finale politropica Polytropic end force polytropische Endfestigkeit force finale polytrophique fuerza finale politrópica força finale politrópica</p>	<p>17 Volume iniziale Initial gas volume Ausgangswert Gasvolumen Volumen inicial de gas Volume de gaz initial Volume de gás inicial</p>		
<p>18 Classificazione PED PED classification PED Einstufung Classification PED Clasificación PED Classificação PED</p>	<p>19 Fissaggi Fixings Befestigungen Fixé Bridas Fixação</p>	<p>20 Indice di revisione pagina Page review index Index der Seiteüberprüfung Index de revue de page Índice de revisión de página Índice de revisão de página</p>	
<p> Tutte le dimensioni senza tolleranza si intendono nominali. All dimensions are nominal unless tolerance is stated. Alle Massgangen ohne Toleranzen sind Nennmasse.</p>			<p>Sauf specifications de tolerances, totes le dimensions sont des valeurs nominales. Todas las dimensiones son nominales excepto cuando se indica la tolerancia. Todas as medidas são nominais excepto quando a tolerancia é mencionada.</p>

SELECTION TAB

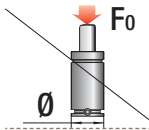

	42 50	70 90	150 200	260 320	360 470	500 680	740	900 1000	1060 1410	1530 2000
12	M 50									
15		M 70								
M 16 x 1,5	NG 16 x 1,5 NE 16 x 1,5									
M 16 x 2	NE 16 x 2									
19		M 90 MS 90	MP 150 RV 170 RS 170							
M 24 x 1,5		M 90 TBM M 90 TEM	NG 24 x 1,5 NE 24 X 1,5							
1"- 8 THD		M 90 TBI								
25			M 200 MS 200	MP 300 ML 300 RV 320 RS 320	KE 400					
32			SC 150	M 300 H 300	RV 350 RS 350 RT 350	ML 500 MP 500 MQ 700	KE 750			
38				SC 250	H 500 RV 500 RS 500 RT 500			ML 1000 MP 1000	KE 1000	
M 38 x 1,5				SCF 250	HF 500					
45					S 500 SC 500		H 700 RV 750 RS 750 RF 750 RT 750 RG 750			
50							SC 750 S 750	H 1000 RV 1000 RS 1000 RF 1000 RT 1000 RG 1000	RV 1200 RS 1200 RF 1200 RT 1200	KE 1800 ML 1800 MP 2000
63										RV 1500 RS 1500 RF 1500 RT 1500 RG 1500 H 1500
75										S 1500 SC 1500 LS 1500

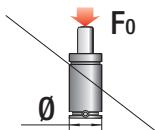

	2035 2385	2830 3000	3180	4240	4418 4980	6630	7540 7700	9540	10600 12720	18400 19910
63		KE 3000 MP 3000	ML 3000							
75	H 2400 LS 2400 RV 2400 RS 2400 RF 2400 RT 2400 RG 2400				KE 4700 ML 4700					
95		LS 3000 S 3000 SC 3000		H 4200 LS 4200 RV 4200 RS 4200 RT 4200 RG 4200			KE 7500 ML 7500			
120					LS 5000 SC 5000	H 6600 LS 6600 RV 6600 RS 6600 RT 6600 RG 6600			KE 12000 ML 12000	
150							SC 7500 LS 7500	H 9500 LS 9500 RV 9500 RS 9500 RT 9500	RV 12000	KE 18500
195									SC 10000	RV 20000 H 18500



NE SERIES

NG SERIES

VDI	BMW	Ford
VW		



VDI	GM	FCA
-----	----	-----

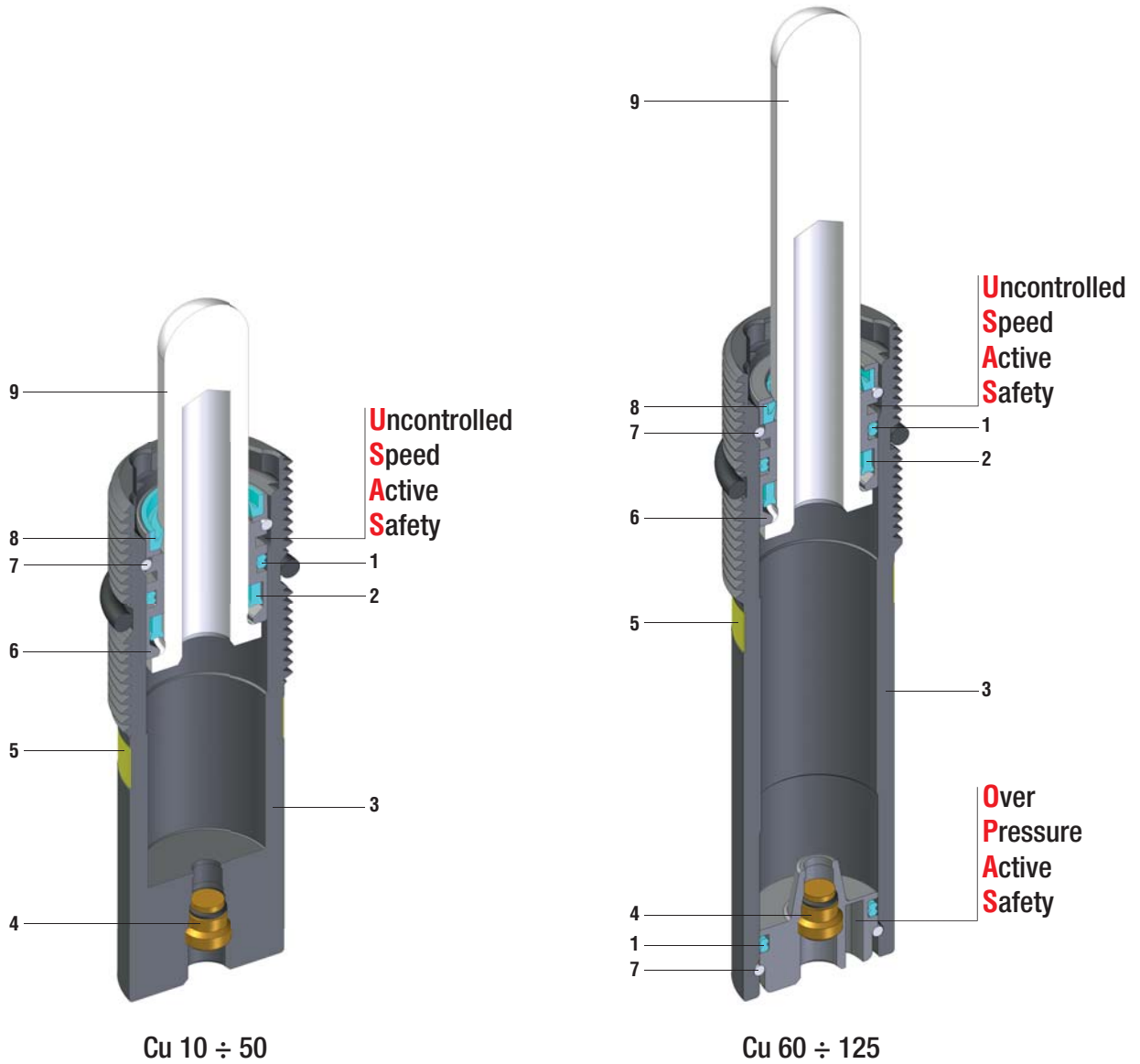

Espulsori a gas - Gas ejectors - Federnde Druckstücke
 Ejectores de gaz - Eyectores de gas - Eyectores a gás

SEALING	ROD SEAL
DESIGN	BUSH - BODY DESIGN

1	Dual ring seal	6	Bush
2	Rod seal	7	Retaining ring
3	Body	8	Rod wiper
4	Valve	9	Rod (nitrited superfinished)
5	Force color code		

RANGE CHART

Model	Body Ø		Stroke Cu		Initial force F0					
	mm	inch	mm	inch	daN	lb				
NE 16 x 1,5	M 16 x 1,5	M 16 x 1.5	10 - 125	0.39 - 4.92	3 - 42	7 - 95	-	✓	-	-
NE 16 x 2	M 16 x 2	M 16 x 2	10 - 125	0.39 - 4.92	3 - 42	7 - 95	-	✓	-	-
NG 16 x 1,5	M 16 x 1,5	M 16 x 1.5	10 - 100	0.39 - 3.94	3 - 42	7 - 95	-	✓	-	-
NE 24 x 1,5	M 24 x 1,5	M 24 x 1.5	10 - 50	0.39 - 1.97	11 - 170	25 - 382	-	✓	-	-
NE 24 x 1,5	M 24 x 1,5	M 24 x 1.5	60 - 125	2.36 - 4.92	11 - 170	25 - 382	-	✓	✓	-
NG 24 x 1,5	M 24 x 1,5	M 24 x 1.5	10 - 50	0.39 - 1.97	11 - 170	25 - 382	-	✓	-	-
NG 24 x 1,5	M 24 x 1,5	M 24 x 1.5	60 - 100	2.36 - 3.94	11 - 170	25 - 382	-	✓	✓	-

**NE
NG**

HOW TO ORDER

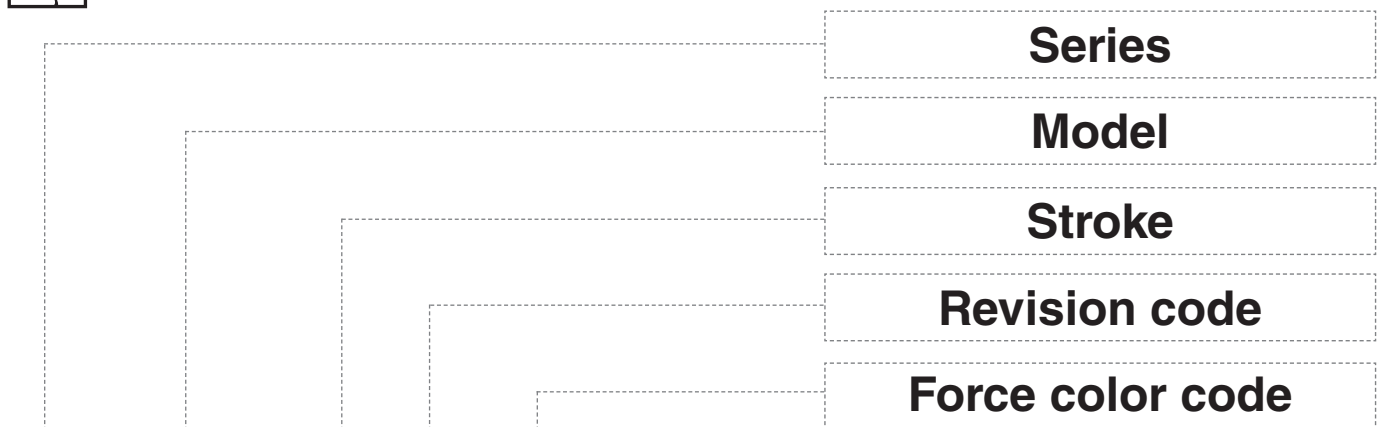

NE 16x1.5-050-B - RD

- IT** Codice cilindro autonomo
- EN** Self-contained cylinder code
- DE** Kode des eingeständigen Gdf.
- FR** Code du cylindre autonome
- ES** Código del cilindro autónomo
- PT** Codigo do cilindro autónomo

- IT** Identificazione delle forze iniziali (vedi tab. "force color code"), se non specificata, si intende sempre forza massima YW. Per forze diverse BK + Fo richiesta.
- EN** Identification of initial forces (see "force color code" chart), if not specified, it is always intended as maximum force YW. For different forces BK + Fo required
- DE** Identifikation der initiales Kräfte (siehe tabelle "force color code"), wenn nicht aufgestellt, es ist immer verstanden als maximaler kraft YW. Für verschiedenen Kräfte, BK + Fo gebrauchte
- FR** Identifies forces initiale (voir tabelle "force color code"), si non specificé, on entend toujours force maximale YW. Pour forces différentes BK + Fo requise
- ES** Identificación de las fuerzas iniciales (veer cuadro "force color code"), si no se especifica, se entiende siempre la maxima fuerza YW. Para fuerzas diferentes BK + Fo requerida
- PT** Identificação das forças iniciais (ver Tabela "force color code"), se não especificado, é sempre entendido a maxima força YW. Para forças diferentes BK + Fo inquerita

NE 16 x 1.5

VDI 3004

W-DX35-60M (Ford)

39D 549 (VW)



ACTIVE SAFETY



USAS

* $F_{1i} =$

Isothermal end force at 100% Cu



p. 16



** $F_{1p} =$

Polytropic end force at 100% Cu

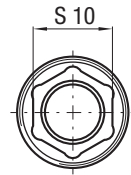
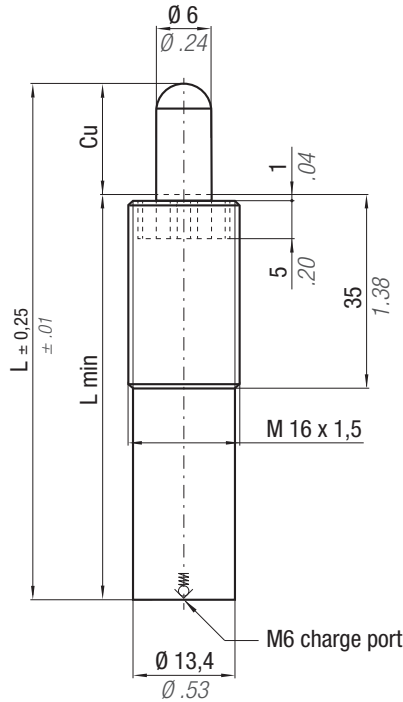

cod. 39CM01A (optional)

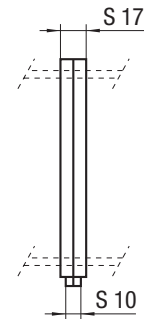

CODE	Cu		L		L min		~Kg		~lb		PED 2014/68/EU	Force color code	P		F0 Initial force ± 5%		F _{1i} End force*	F _{1p} End force**	
	mm	inch	mm	inch	mm	inch			bar	psi			daN	lb	+20°C	+68°F			
NE 16 x 1,5-010-B-...	10	0.39	65	2.56	55	2.17	0,05	0.11	✓										
NE 16 x 1,5-020-B-...	20	0.79	85	3.35	65	2.56	0,06	0.13	✓										
NE 16 x 1,5-030-B-...	30	1.18	105	4.13	75	2.95	0,07	0.15	✓										
NE 16 x 1,5-040-B-...	40	1.57	125	4.92	85	3.35	0,07	0.15	✓										
NE 16 x 1,5-050-B-...	50	1.97	145	5.71	95	3.74	0,08	0.18	✓										
NE 16 x 1,5-060-B-...	60	2.36	165	6.50	105	4.13	0,08	0.18	✓										
NE 16 x 1,5-070-B-...	70	2.76	185	7.28	115	4.53	0,09	0.20	✓										
NE 16 x 1,5-080-B-...	80	3.15	205	8.07	125	4.92	0,10	0.22	✓										
NE 16 x 1,5-100-B-...	100	3.94	245	9.65	145	5.71	0,11	0.24	✓										
NE 16 x 1,5-125-B-...	125	4.92	295	11.61	170	6.69	0,12	0.26	✓										

P = nominal charging pressure

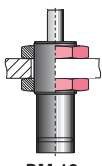

DM 16

HOW TO ORDER

(10 pcs) NE16x1.5-050-B-YW

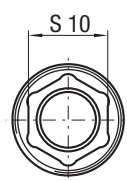
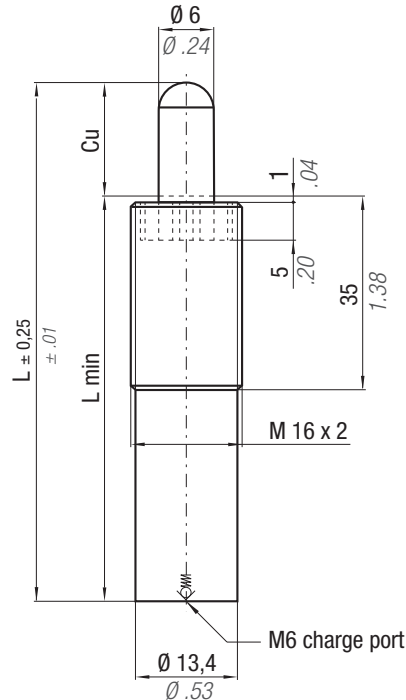

cod. 39CM01A
(optional)

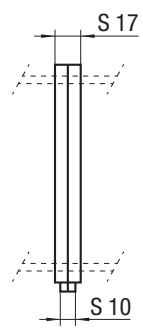

* F_{1i} = Isothermal end force at 100% Cu p. 16
 ** F_{1p} = Polytrophic end force at 100% Cu

ACTIVE SAFETY



NE
NG

	$^{\circ}\text{F}$ 32 - 176	$^{\circ}\text{C}$ 0 - 80	ΔP $\pm 0,33\% / ^{\circ}\text{C}$	P max 150 bar 2175 psi	P min 10 bar 145 psi	S 0,28 cm ² 0.043 in ²	SPM ~ 50 - 100 (at 20°C)	Max Speed 1,8 m/s	Maintenance kit Disposable
--	--------------------------------------	------------------------------------	---	-------------------------------------	-----------------------------------	---	---------------------------------------	-----------------------------	--------------------------------------

CODE	Cu		L		L min		~Kg ~lb		PED 2014/68/EU	Force color code	P		F ₀ Initial force ± 5% +20°C +68°F		F _{1i} End force*	F _{1p} End force**
	mm	inch	mm	inch	mm	inch					bar	psi	daN	lb		
NE 16 x 2-010-B-...	10	0.39	65	2.56	55	2.17	0,05	0.11	✓							
NE 16 x 2-020-B-...	20	0.79	85	3.35	65	2.56	0,06	0.13	✓							
NE 16 x 2-030-B-...	30	1.18	105	4.13	75	2.95	0,07	0.15	✓	PR	12	174	4	9	1,56 x F ₀	2,03 x F ₀
NE 16 x 2-040-B-...	40	1.57	125	4.92	85	3.35	0,07	0.15	✓	GR	20	290	6	14	1,56 x F ₀	2,03 x F ₀
NE 16 x 2-050-B-...	50	1.97	145	5.71	95	3.74	0,08	0.18	✓	BU	40	580	11	25	1,56 x F ₀	2,03 x F ₀
NE 16 x 2-060-B-...	60	2.36	165	6.50	105	4.13	0,08	0.18	✓	RD	75	1088	21	47	1,56 x F ₀	2,03 x F ₀
NE 16 x 2-070-B-...	70	2.76	185	7.28	115	4.53	0,09	0.20	✓	YW	150	2175	42	95	1,56 x F ₀	2,03 x F ₀
NE 16 x 2-080-B-...	80	3.15	205	8.07	125	4.92	0,10	0.22	✓	BK	10-150	145-2175	3-42	7-95	1,56 x F ₀	2,03 x F ₀
NE 16 x 2-100-B-...	100	3.94	245	9.65	145	5.71	0,11	0.24	✓							
NE 16 x 2-125-B-...	125	4.92	295	11.61	170	6.69	0,12	0.26	✓							

P = nominal charging pressure

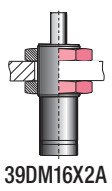

39DM16X2A

HOW TO ORDER

(10 pcs) NE16x2-050-B-YW

NE 24 x 1.5

VDI 3004

W-DX35-60M (Ford)

39D 549 (VW)



ACTIVE SAFETY



USAS



OPAS

* $F_{1i} =$

Isothermal end force at 100% Cu



p. 16



** $F_{1p} =$

Polytropic end force at 100% Cu

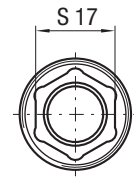
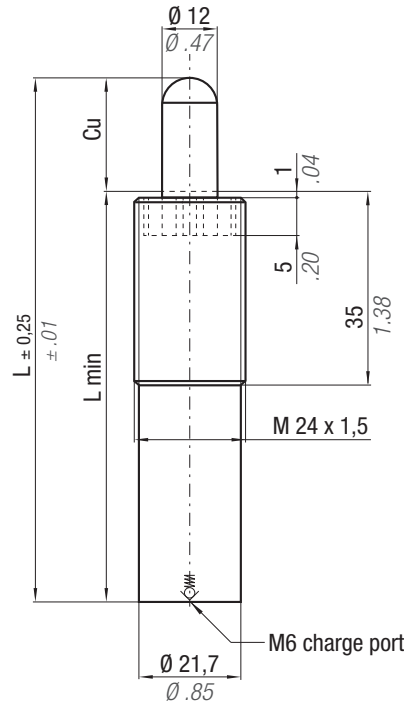

cod. 39CM01A (optional)

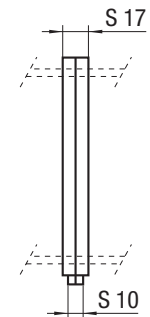

CODE	Cu		L		L min		~Kg		PED 2014/68/EU	Force color code	P		F0 Initial force ± 5%		F _{1i} End force*	F _{1p} End force**
	mm	inch	mm	inch	mm	inch	~Kg	~lb			bar	psi	daN	lb		
NE 24 x 1,5-010-B-...	10	0.39	65	2.56	55	2.17	0,16	0.35	✓	GR	20	290	23	52	1,85 x F0	2,53 x F0
NE 24 x 1,5-020-B-...	20	0.79	85	3.35	65	2.56	0,18	0.40	✓	BU	40	580	45	101	1,85 x F0	2,53 x F0
NE 24 x 1,5-030-B-...	30	1.18	105	4.13	75	2.95	0,20	0.44	✓	RD	75	1088	85	191	1,85 x F0	2,53 x F0
NE 24 x 1,5-040-B-...	40	1.57	125	4.92	85	3.35	0,23	0.51	✓	YW	150	2175	170	382	1,85 x F0	2,53 x F0
NE 24 x 1,5-050-B-...	50	1.97	145	5.71	95	3.74	0,25	0.55	✓	BK	10-150	145-2175	11-170	25-382	1,85 x F0	2,53 x F0
NE 24 x 1,5-060-B-...	60	2.36	165	6.50	105	4.13	0,27	0.59	✓							
NE 24 x 1,5-070-B-...	70	2.76	185	7.28	115	4.53	0,29	0.64	✓							
NE 24 x 1,5-080-B-...	80	3.15	205	8.07	125	4.92	0,30	0.66	✓							
NE 24 x 1,5-100-B-...	100	3.94	245	9.65	145	5.71	0,33	0.73	✓							
NE 24 x 1,5-125-B-...	125	4.92	295	11.61	170	6.69	0,35	0.77	✓							

P = nominal charging pressure

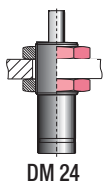

DM 24

HOW TO ORDER

(10 pcs) NE24x1.5-050-B-YW

NG 24 x 1.5

VDI 3004 90.25.96 (GM)	075.90.40 (FCA) 39D 549 (VW)	W-DX35-60M (Ford)	90.25.95 (GM)
---------------------------	---------------------------------	-------------------	---------------



ACTIVE SAFETY



USAS



OPAS

* $F_{1i} =$

Isothermal end force at 100% Cu



p. 16



** $F_{1p} =$

Polytropic end force at 100% Cu

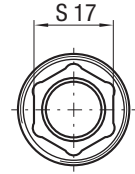
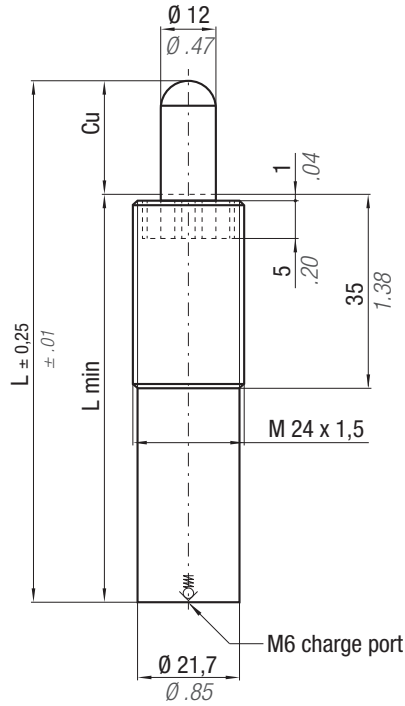

cod. 39CM01A (optional)

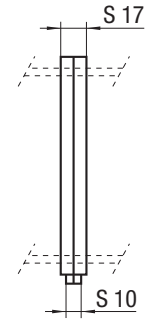

CODE	Cu		L		L min		~Kg		~lb	PED 2014/68/EU	Force color code	P		F ₀ Initial force ± 5%		F _{1i} End force*	F _{1p} End force**
	mm	inch	mm	inch	mm	inch						bar	psi	daN	lb		
NG 24 x 1,5-010-A-...	10	0.39	80	3.15	70	2.76	0,15	0.33	✓								
NG 24 x 1,5-020-A-...	20	0.79	100	3.94	80	3.15	0,17	0.37	✓								
NG 24 x 1,5-030-A-...	30	1.18	120	4.72	90	3.54	0,19	0.42	✓								
NG 24 x 1,5-040-A-...	40	1.57	140	5.51	100	3.94	0,22	0.49	✓								
NG 24 x 1,5-050-A-...	50	1.97	160	6.30	110	4.33	0,24	0.53	✓								
NG 24 x 1,5-060-A-...	60	2.36	180	7.09	120	4.72	0,26	0.57	✓								
NG 24 x 1,5-070-A-...	70	2.76	200	7.87	130	5.12	0,28	0.62	✓								
NG 24 x 1,5-080-A-...	80	3.15	220	8.66	140	5.51	0,29	0.64	✓								
NG 24 x 1,5-100-A-...	100	3.94	260	10.24	160	6.30	0,31	0.68	✓								

P = nominal charging pressure

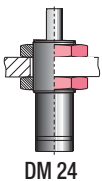

DM 24

HOW TO ORDER

(10 pcs) NG24x1.5-050-A-BR



THIS PAGE IS INTENTIONALLY LEFT BLANK



VDI	BMW	FCA
Ford	MB	PSA
VW		

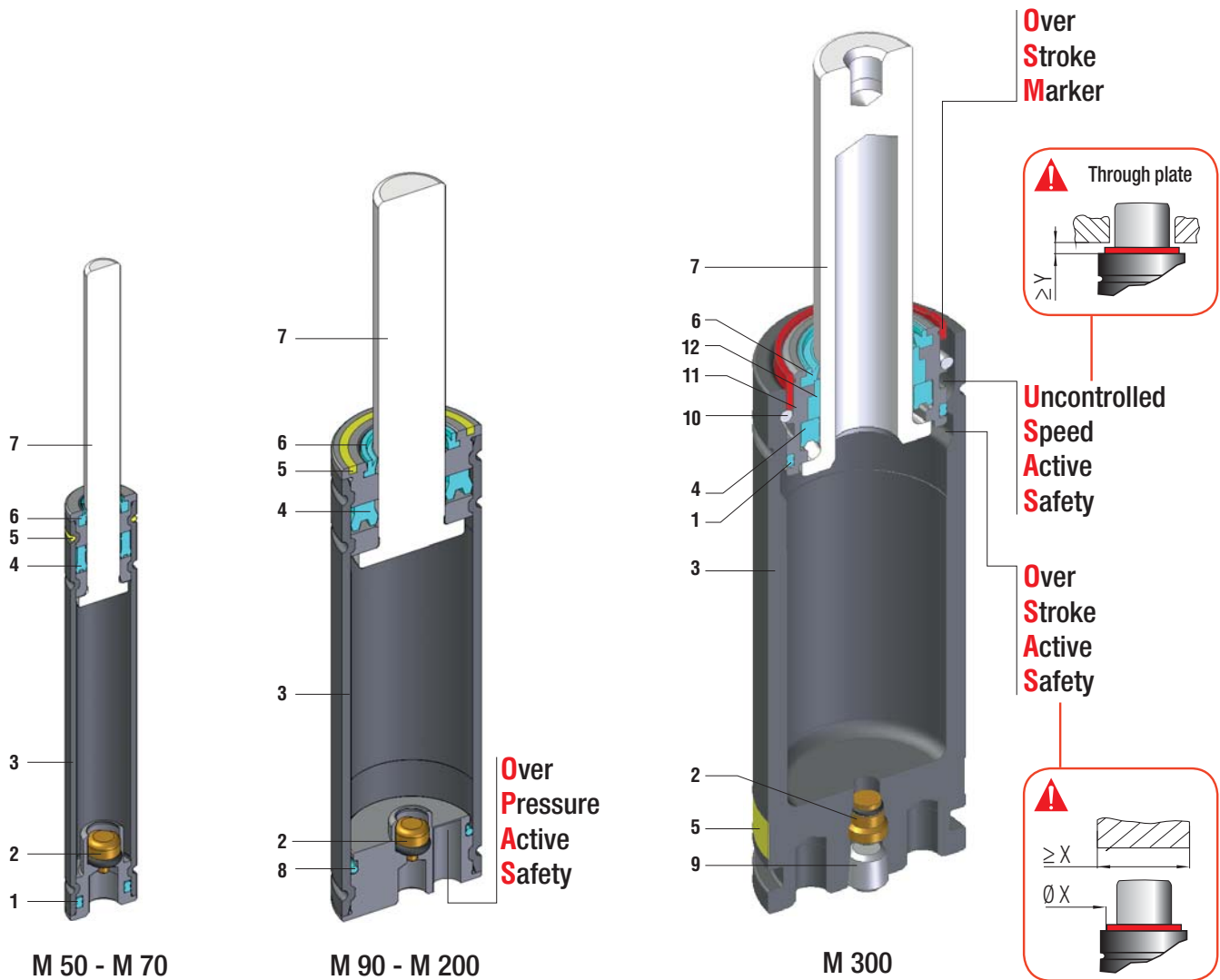





Mini cilindri - Mini cylinders - Mini Gasdruckfedern
 Mini-ressorts - Mini cilindros - Mini-cilindros

SEALING	ROD SEAL
DESIGN	RETAINING GROOVE DESIGN
	BUSH-BODY DESIGN (M300 only)

1	Dual ring seal	5	Force color code	9	Stopper
2	Valve	6	Rod wiper	10	Retaining ring
3	Body	7	Rod (Nitrited Superfinished)	11	Bush
4	Rod seal	8	O-ring	12	Guide ring

RANGE CHART

Model	Body Ø		Stroke Cu		Initial force F0					
	mm	inch	mm	inch	daN	lb				
M 50	12	0.47	7 - 125	0.28 - 4.92	6 - 50	13 - 112	-	-	-	-
M 70	15	0.59	7 - 125	0.28 - 4.92	8 - 70	18 - 157	-	-	-	-
M 90	19	0.75	7 - 125	0.28 - 4.92	5 - 90	11 - 202	-	-	✓	-
M 90 TBM	M 24 X 1,5	M 24 X 1.5	7 - 125	0.28 - 4.92	5 - 90	11 - 202	-	-	✓	-
M 90 TEM	M 24 X 1,5	M 24 X 1.5	7 - 125	0.28 - 4.92	5 - 90	11 - 202	-	-	✓	-
M 90 TBI	1" 8 THD	1" 8 THD	7 - 125	0.28 - 4.92	5 - 90	11 - 202	-	-	✓	-
M 200	25	0.98	7 - 125	0.28 - 4.92	17 - 200	38 - 450	-	-	✓	-
M 300	32	1.26	7 - 125	0.28 - 4.92	80 - 320	180 - 719	✓	✓	-	-

M



HOW TO ORDER

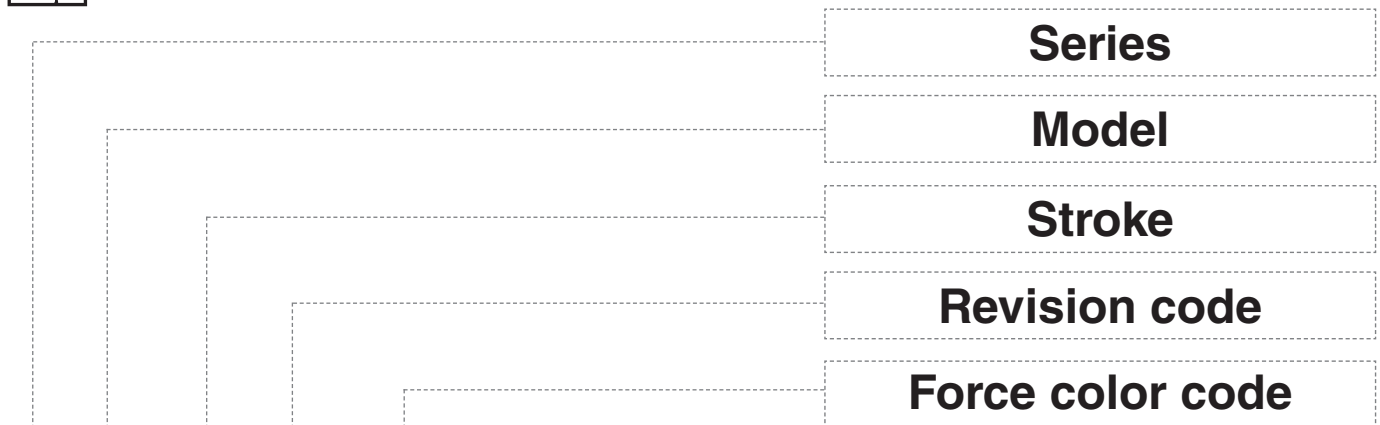

M 90-050-A - RD

- IT** Codice cilindro autonomo
- EN** Self-contained cylinder code
- DE** Kode des eingeständigen Gdf.
- FR** Code du cylindre autonome
- ES** Código del cilindro autónomo
- PT** Codigo do cilindro autónomo

- IT** Identificazione delle forze iniziali (vedi tab. "force color code"), se non specificata, si intende sempre forza massima YW. Per forze diverse BK + Fo richiesta.
- EN** Identification of initial forces (see "force color code" chart), if not specified, it is always intended as maximum force YW. For different forces BK + Fo required
- DE** Identifikation der initiales Kräfte (siehe tabelle "force color code"), wenn nicht aufgestellt, es ist immer verstanden als maximaler Kraft YW. Für verschiedenen Kräfte, BK + Fo gebrauchte
- FR** Identifies forces initiale (voir tabelle "force color code"), si non specificé, on entend toujours force maximale YW. Pour forces différentes BK + Fo requise
- ES** Identificación de las fuerzas iniciales (veer cuadro "force color code"), si no se especifica, se entiende siempre la maxima fuerza YW. Para fuerzas diferentes BK + Fo requerida
- PT** Identificação das forças iniciais (ver Tabela "force color code"), se não especificado, é sempre entendido a maxima força YW. Para forças diferentes BK + Fo inquerita



ACTIVE SAFETY

* F_{1i} = Isothermal end force at 100% Cu p. 16 ** F_{1p} = Polytrophic end force at 100% Cu

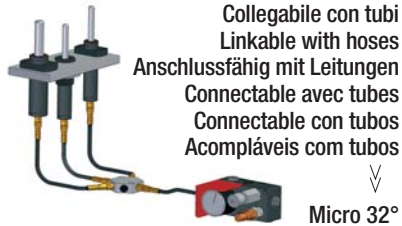

Force color code	P		Fo Initial force ± 5% at +20°C +68°F	
	bar	psi	daN	lb
GR	45	653	13	29
BU	90	1305	25	56
RD	135	1958	38	85
YW	180	2610	50	112
BK	20-180	290-2610	6-50	13-112

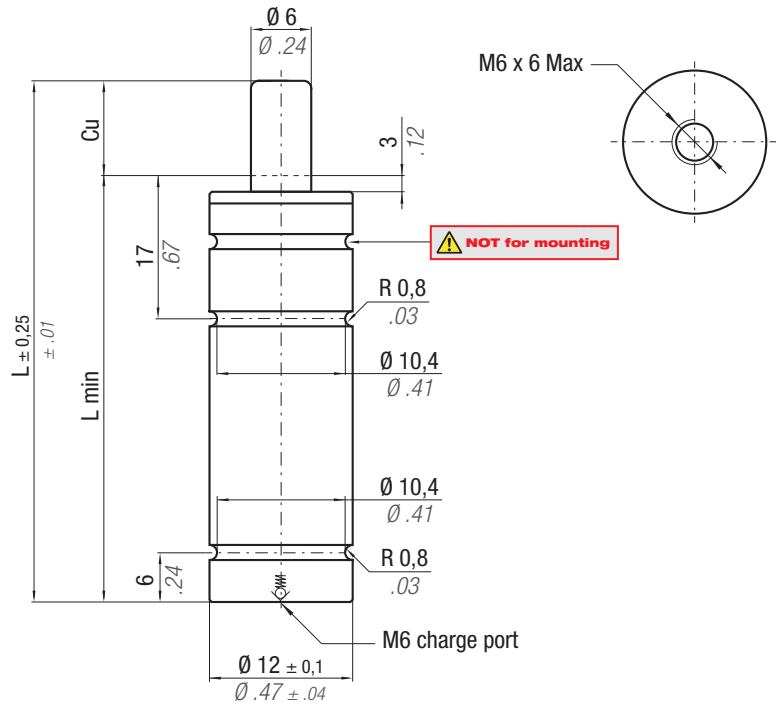

CODE	N ₂	°F 32 - 176	°C 0 - 80	ΔP ± 0,33 %/°C	P max 180 bar 2610 psi	P min 20 bar 290 psi	S 0,28 cm ² 0,043 in ²	SPM ~ 100 - 150 (at 20°C)	Max Speed 1,8 m/s	Maintenance kit Disposable	Vo		PED	
											cm ³	in ³	~Kg	~lb
M50-007-A-...											0,03	0,07	✓	
M50-010-A-...											0,03	0,07	✓	
M50-013-A-...											0,03	0,07	✓	
M50-015-A-...											0,03	0,07	✓	
M50-019-A-...											0,03	0,07	✓	
M50-025-A-...											0,03	0,07	✓	
M50-038-A-...											0,04	0,09	✓	
M50-050-A-...											0,05	0,11	✓	
M50-063-A-...											0,06	0,13	✓	
M50-075-A-...											0,06	0,13	✓	
M50-080-A-...											0,07	0,15	✓	
M50-100-A-...											0,08	0,18	✓	
M50-125-A-...											0,09	0,20	✓	

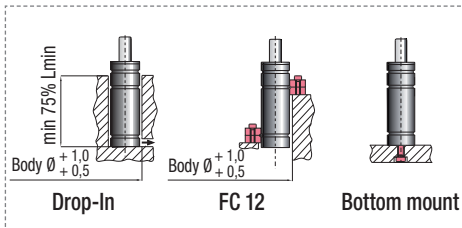

HOW TO ORDER

(10 pcs) M50-050-A-YW

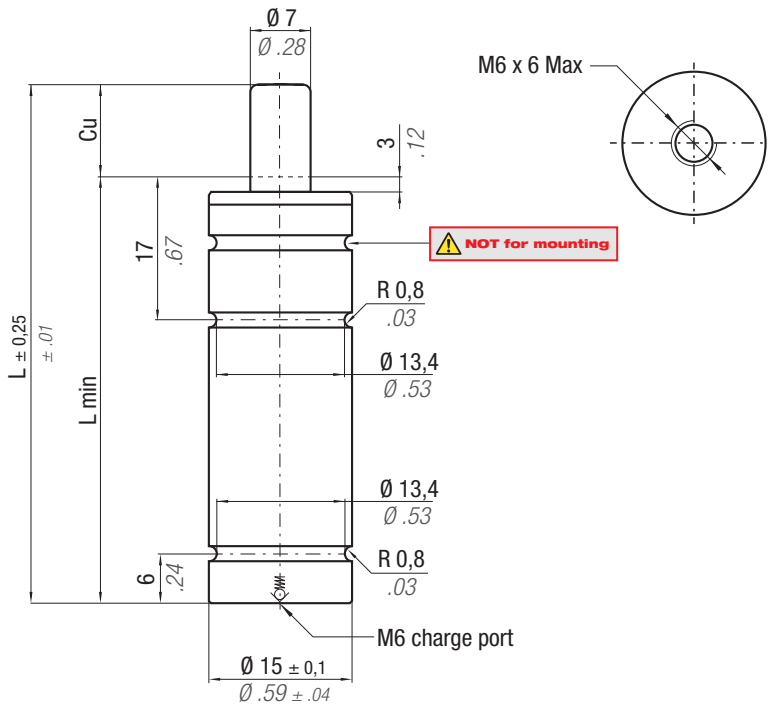

* $F_{1i} =$

Isothermal
end force
at 100% Cu

p. 16

** $F_{1p} =$

Polytropic
end force
at 100% Cu



**ACTIVE
SAFETY**

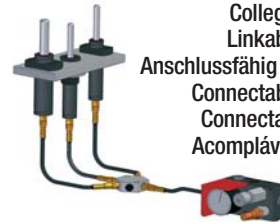

Collegabile con tubi
Linkable with hoses
Anschlussfähig mit Leitungen
Connectable avec tubes
Connectable con tubos
Acompláveis com tubos

Micro 32°

Force color code	P		Fo Initial force ± 5% at +20°C +68°F	
	bar	psi	daN	lb
GR	45	653	18	40
BU	90	1305	35	79
RD	135	1958	50	112
YW	180	2610	70	157
BK	20-180	290-2610	8-70	18-157

CODE	N ₂	°F 32 - 176	°C 0 - 80	ΔP ± 0,33 %/°C	P max 180 bar 2610 psi	P min 20 bar 290 psi	S 0,38 cm ² 0.059 in ²	SPM ~ 100 - 150 (at 20°C)	Max Speed 1,8 m/s	Maintenance kit Disposable	Cu		L		L min		F _{1i} *		F _{1p} **		V ₀		~Kg	~lb	PED 2014/68/EU
											mm	inch	mm	inch	mm	inch	daN	lb	daN	lb	cm ³	in ³			
M70 - 007 - A - ...												7	0.28	56	2.20	49	1.93	1,28 x F ₀	1,47 x F ₀	-	-	0,04	0.09	✓	
M70 - 010 - A - ...												10	0.39	62	2.44	52	2.05	1,34 x F ₀	1,56 x F ₀	-	-	0,05	0.11	✓	
M70 - 013 - A - ...												12,7	0.50	67,4	2.65	54,7	2.15	1,37 x F ₀	1,61 x F ₀	-	-	0,05	0.11	✓	
M70 - 015 - A - ...												15	0.59	72	2.83	57	2.24	1,40 x F ₀	1,66 x F ₀	-	-	0,05	0.11	✓	
M70 - 019 - A - ...												19	0.75	80	3.15	61	2.40	1,43 x F ₀	1,72 x F ₀	-	-	0,05	0.11	✓	
M70 - 025 - A - ...												25	0.98	92	3.62	67	2.64	1,47 x F ₀	1,78 x F ₀	-	-	0,06	0.13	✓	
M70 - 038 - A - ...												38	1.50	118	4.65	80	3.15	1,51 x F ₀	1,85 x F ₀	-	-	0,07	0.15	✓	
M70 - 050 - A - ...												50	1.97	142	5.59	92	3.62	1,54 x F ₀	1,89 x F ₀	-	-	0,08	0.18	✓	
M70 - 063 - A - ...												63,5	2.50	172	6.77	108,5	4.27	1,52 x F ₀	1,87 x F ₀	-	-	0,09	0.20	✓	
M70 - 075 - A - ...												75	2.95	195	7.68	120	4.72	1,54 x F ₀	1,89 x F ₀	-	-	0,10	0.22	✓	
M70 - 080 - A - ...												80	3.15	205	8.071	125	4.92	1,54 x F ₀	1,90 x F ₀	-	-	0,10	0.22	✓	
M70 - 100 - A - ...												100	3.94	245	9.65	145	5.71	1,56 x F ₀	1,93 x F ₀	-	-	0,12	0.26	✓	
M70 - 125 - A - ...												125	4.92	295	11.61	170	6.69	1,57 x F ₀	1,95 x F ₀	-	-	0,14	0.31	✓	

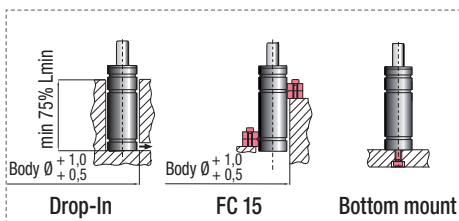

HOW TO ORDER

(10 pcs) M70-050-A-YW



ACTIVE SAFETY



OPAS

* $F_{1i} =$ Isothermal end force at 100% Cu p. 16 **** $F_{1p} =$** Polytrophic end force at 100% Cu

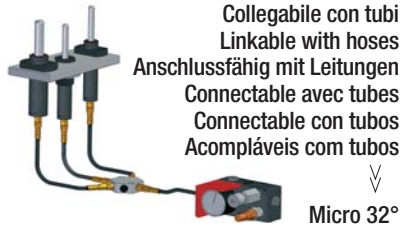

Force color code	P		Fo Initial force $\pm 5\%$ at $+20^\circ\text{C} +68^\circ\text{F}$	
	bar	psi	daN	lb
OR	10	145	5	11
PR	20	290	10	22
GR	60	870	30	67
BU	100	1450	50	112
RD	140	2030	70	157
YW	180	2610	90	202
BK	10-180	145-2610	5-90	11-202

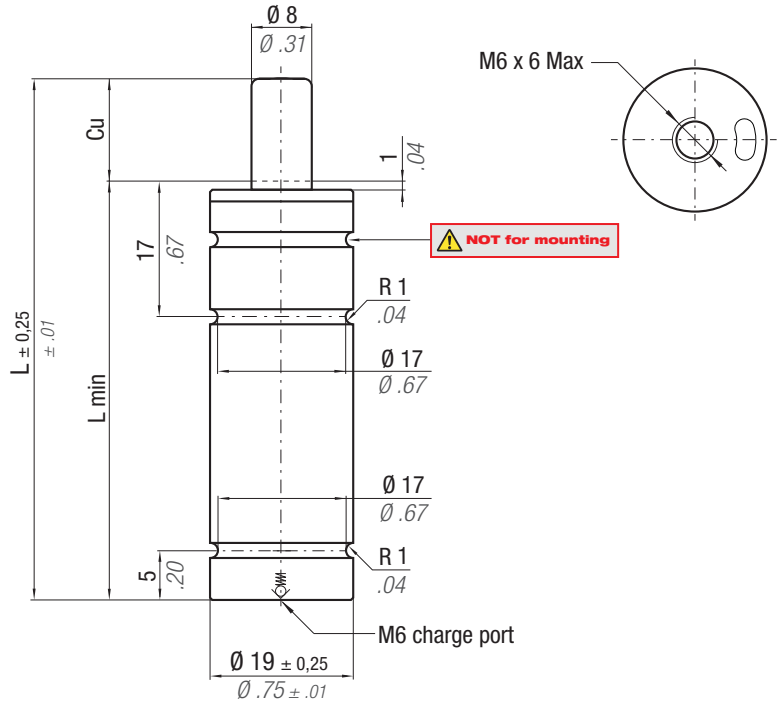

	32°F -176°C	0°C -80°F	ΔP $\pm 0,33\% / ^\circ\text{C}$	P max 180 bar 2610 psi	P min 10 bar 145 psi	S $0,5 \text{ cm}^2$ $0,078 \text{ in}^2$	SPM $\sim 100 - 150$ (at 20°C)	Max Speed 1,8 m/s	Maintenance kit Disposable
--	--	--	---	-------------------------------------	-----------------------------------	--	--	-----------------------------	--------------------------------------

CODE	Cu		L		L min		F _{1i} * End force *		F _{1p} ** End force **		Vo		PED 2014/68/EU		
	mm	inch	mm	inch	mm	inch	daN	lb	daN	lb	cm ³	in ³	~Kg	~lb	
M90 - 007 - A - ...	7	0.28	56	2.20	49	1.93	1,16 x F0		1,30 x F0		-	-	0,07	0.15	✓
M90 - 010 - A - ...	10	0.39	62	2.44	52	2.05	1,19 x F0		1,36 x F0		-	-	0,07	0.15	✓
M90 - 013 - A - ...	12,7	0.50	67,4	2.65	54,7	2.15	1,22 x F0		1,40 x F0		-	-	0,08	0.18	✓
M90 - 015 - A - ...	15	0.59	72	2.83	57	2.24	1,23 x F0		1,42 x F0		-	-	0,08	0.18	✓
M90 - 025 - A - ...	25	0.98	92	3.62	67	2.64	1,28 x F0		1,50 x F0		-	-	0,09	0.20	✓
M90 - 038 - A - ...	38,1	1.50	118,2	4.65	80,1	3.15	1,31 x F0		1,55 x F0		-	-	0,11	0.24	✓
M90 - 050 - A - ...	50	1.97	142	5.59	92	3.62	1,33 x F0		1,58 x F0		-	-	0,12	0.26	✓
M90 - 063 - A - ...	63,5	2.50	172	6.77	108,5	4.27	1,33 x F0		1,57 x F0		-	-	0,14	0.31	✓
M90 - 080 - A - ...	80	3.15	205	8.07	125	4.92	1,34 x F0		1,59 x F0		-	-	0,15	0.33	✓
M90 - 100 - A - ...	100	3.94	245	9.65	145	5.71	1,35 x F0		1,61 x F0		-	-	0,17	0.37	✓
M90 - 125 - A - ...	125	4.92	295	11.61	170	6.69	1,36 x F0		1,63 x F0		-	-	0,20	0.44	✓

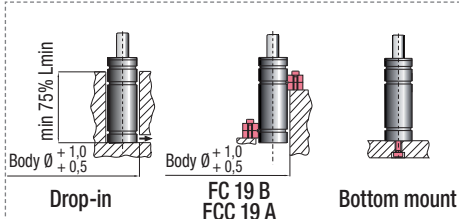

HOW TO ORDER

(10 pcs) M90-050-A-YW

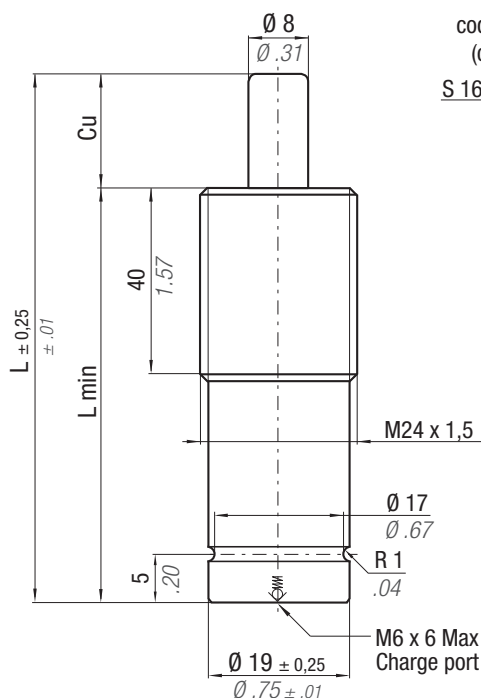

cod. 39 TBT (optional)

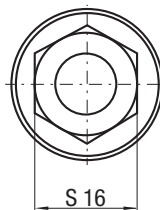
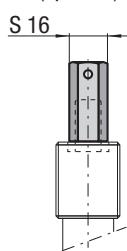

!
Senza riserva corsa
Without reserve of stroke
Ohne Hubreserve
Sans course de réserve
Sin margen de Carrera
Sem reserva de curso

!
NON superare 90% Cu
DO NOT exceed 90% Cu
NICHT überschreiten die 90% Cu
NE PAS dépasser 90% Cu
NO superar el 90% Cu
NÃO se excedam os 90% Cu

* $F_{1i} =$

Isothermal end force at 100% Cu



p. 16



** $F_{1p} =$

Polytrophic end force at 100% Cu

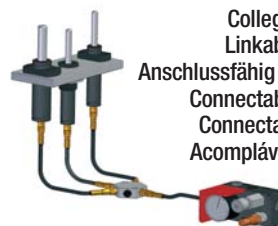

Collegabile con tubi
Linkable with hoses
Anschlussfähig mit Leitungen
Connectable avec tubes
Connectable con tubos
Acompláveis com tubos

Micro 32°

ACTIVE SAFETY



OPAS

Force color code	P		Fo	
	bar	psi	Initial force ± 5% at +20°C +68°F	
OR	10	145	5	11
PR	20	290	10	22
GR	60	870	30	67
BU	100	1450	50	112
RD	140	2030	70	157
YW	180	2610	90	202
BK	10-180	145-2610	5-90	11-202

	°F 32 - 176	°C 0 - 80	ΔP ± 0,33 %/°C	P max 180 bar 2610 psi	P min 10 bar 145 psi	S 0,5 cm ² 0.078 in ²	SPM ~ 100 - 150 (at 20°C)	Max Speed 1,8 m/s	Maintenance kit Disposable
--	----------------------	--------------------	---------------------------	------------------------------	----------------------------	---	---------------------------------	----------------------	-------------------------------

CODE	Cu		L		L min		F_{1i} *		F_{1p} **		Vo		~Kg	~lb	PED 2014/68/EU
	mm	inch	mm	inch	mm	inch	daN	lb	daN	lb	cm ³	in ³			
M90 - 007 - A - ...	7	0.28	56	2.20	49	1.93	1,16 x F0		1,30 x F0		-	-	0,07	0.15	✓
M90 - 010 - A - ...	10	0.39	62	2.44	52	2.05	1,19 x F0		1,36 x F0		-	-	0,07	0.15	✓
M90 - 013 - A - ...	12,7	0.50	67,4	2.65	54,7	2.15	1,22 x F0		1,40 x F0		-	-	0,08	0.18	✓
M90 - 015 - A - ...	15	0.59	72	2.83	57	2.24	1,23 x F0		1,42 x F0		-	-	0,08	0.18	✓
M90 - 025 - A - ...	25	0.98	92	3.62	67	2.64	1,28 x F0		1,50 x F0		-	-	0,09	0.20	✓
M90 - 038 - A - ...	38,1	1.50	118,2	4.65	80,1	3.15	1,31 x F0		1,55 x F0		-	-	0,11	0.24	✓
M90 - 050 - A - ...	50	1.97	142	5.59	92	3.62	1,33 x F0		1,58 x F0		-	-	0,12	0.26	✓
M90 - 063 - A - ...	63,5	2.50	172	6.77	108,5	4.27	1,33 x F0		1,57 x F0		-	-	0,14	0.31	✓
M90 - 080 - A - ...	80	3.15	205	8.07	125	4.92	1,34 x F0		1,59 x F0		-	-	0,15	0.33	✓
M90 - 100 - A - ...	100	3.94	245	9.65	145	5.71	1,35 x F0		1,61 x F0		-	-	0,17	0.37	✓
M90 - 125 - A - ...	125	4.92	295	11.61	170	6.69	1,36 x F0		1,63 x F0		-	-	0,20	0.44	✓

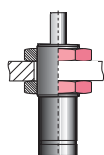

DM 24

HOW TO ORDER

(10 pcs)
M90-050-A-YW-TBM

ACTIVE SAFETY



* $F_{1i} =$ Isothermal end force at 100% Cu
 ** $F_{1p} =$ Polytropic end force at 100% Cu

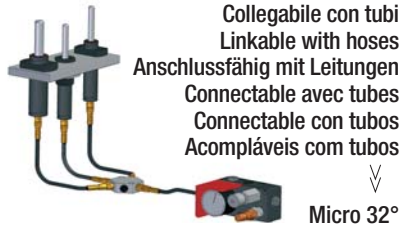

Force color code	P		F ₀ Initial force ± 5% at +20°C +68°F	
	bar	psi	daN	lb
OR	10	145	5	11
PR	20	290	10	22
GR	60	870	30	67
BU	100	1450	50	112
RD	140	2030	70	157
YW	180	2610	90	202
BK	10-180	145-2610	5-90	11-202

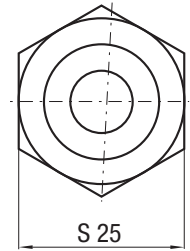
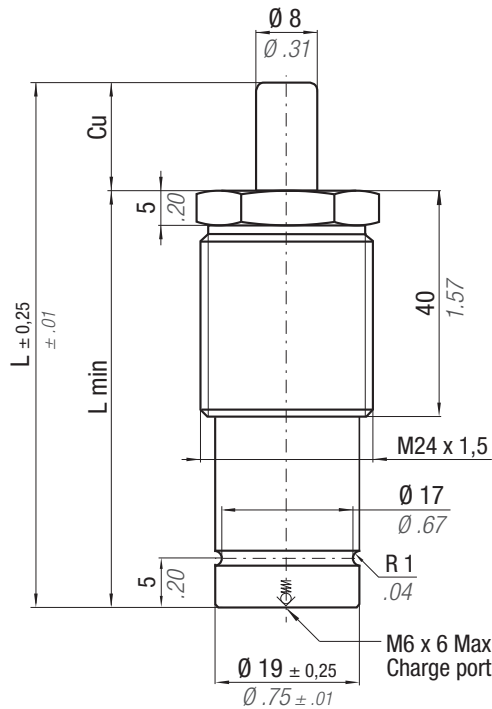

!
Senza riserva corsa
Without reserve of stroke
Ohne Hubreserve
Sans course de réserve
Sin margen de Carrera
Sem reserva de curso

!
NON superare 90% Cu
DO NOT exceed 90% Cu
NICHT überschreiten die 90% Cu
NE PAS dépasser 90% Cu
NO superar el 90% Cu
NÃO se excedam os 90% Cu

	$^{\circ}\text{F}$ 32 - 176	$^{\circ}\text{C}$ 0 - 80	ΔP $\pm 0,33\% / ^{\circ}\text{C}$	P max 180 bar 2610 psi	P min 10 bar 145 psi	S 0,5 cm ² 0.078 in ²	SPM ~ 100 - 150 (at 20°C)	Max Speed 1,8 m/s	Maintenance kit Disposable
--	--------------------------------------	------------------------------------	---	-------------------------------------	-----------------------------------	--	--	-----------------------------	--------------------------------------

CODE	Cu		L		L min		F _{1i} * End force *		F _{1p} ** End force **		V ₀		PED 2014/68/EU		
	mm	inch	mm	inch	mm	inch	daN	lb	daN	lb	cm ³	in ³	~Kg	~lb	✓
M90-007-A-...	7	0.28	56	2.20	49	1.93	1,16 x F ₀		1,30 x F ₀		-	-	0,07	0.15	✓
M90-010-A-...	10	0.39	62	2.44	52	2.05	1,19 x F ₀		1,36 x F ₀		-	-	0,07	0.15	✓
M90-013-A-...	12,7	0.50	67,4	2.65	54,7	2.15	1,22 x F ₀		1,40 x F ₀		-	-	0,08	0.18	✓
M90-015-A-...	15	0.59	72	2.83	57	2.24	1,23 x F ₀		1,42 x F ₀		-	-	0,08	0.18	✓
M90-025-A-...	25	0.98	92	3.62	67	2.64	1,28 x F ₀		1,50 x F ₀		-	-	0,09	0.20	✓
M90-038-A-...	38,1	1.50	118,2	4.65	80,1	3.15	1,31 x F ₀		1,55 x F ₀		-	-	0,11	0.24	✓
M90-050-A-...	50	1.97	142	5.59	92	3.62	1,33 x F ₀		1,58 x F ₀		-	-	0,12	0.26	✓
M90-063-A-...	63,5	2.50	172	6.77	108,5	4.27	1,33 x F ₀		1,57 x F ₀		-	-	0,14	0.31	✓
M90-080-A-...	80	3.15	205	8.07	125	4.92	1,34 x F ₀		1,59 x F ₀		-	-	0,15	0.33	✓
M90-100-A-...	100	3.94	245	9.65	145	5.71	1,35 x F ₀		1,61 x F ₀		-	-	0,17	0.37	✓
M90-125-A-...	125	4.92	295	11.61	170	6.69	1,36 x F ₀		1,63 x F ₀		-	-	0,20	0.44	✓

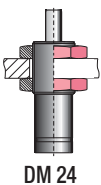

DM 24

HOW TO ORDER

(10 pcs)
M90-050-A-YW-TEM

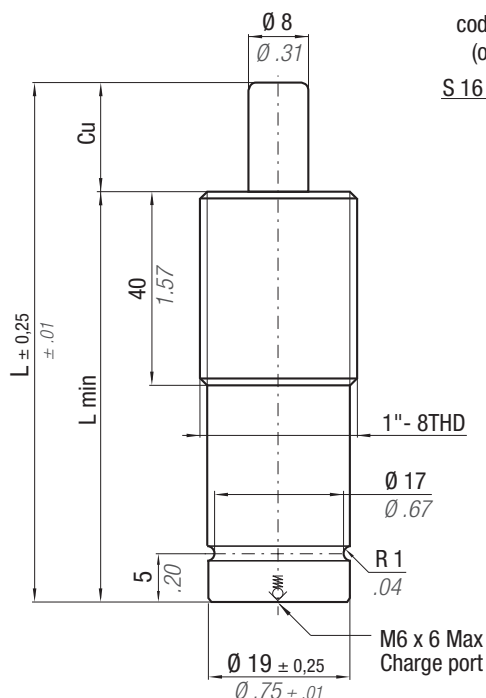

cod. 39 TBT (optional)

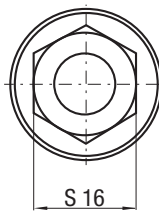
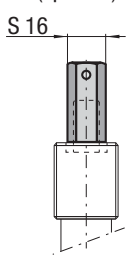

!
Senza riserva corsa
Without reserve of stroke
Ohne Hubreserve
Sans course de réserve
Sin margen de Carrera
Sem reserva de curso

!
NON superare 90% Cu
DO NOT exceed 90% Cu
NICHT überschreiten die 90% Cu
NE PAS dépasser 90% Cu
NO superar el 90% Cu
NÃO se excedam os 90% Cu

* F_{1i} =

Isothermal end force at 100% Cu

** F_{1p} =

Polytrophic end force at 100% Cu

p. 16

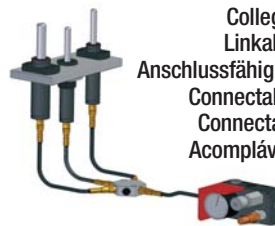

Collegabile con tubi
Linkable with hoses
Anschlussfähig mit Leitungen
Connectable avec tubes
Connectable con tubos
Acompláveis com tubos

Micro 32°

ACTIVE SAFETY



Force color code	P		F ₀	
	bar	psi	Initial force ± 5% at +20°C +68°F	
OR	10	145	5	11
PR	20	290	10	22
GR	60	870	30	67
BU	100	1450	50	112
RD	140	2030	70	157
YW	180	2610	90	202
BK	10-180	145-2610	5-90	11-202

	°F 32 176	°C 0 80	ΔP ± 0,33 %/°C	P max 180 bar 2610 psi	P min 10 bar 145 psi	S 0,5 cm ² 0.078 in ²	SPM ~ 100 - 150 (at 20°C)	Max Speed 1,8 m/s	Maintenance kit Disposable
--	-----------------	---------------	---------------------------	------------------------------	----------------------------	---	---------------------------------	----------------------	-------------------------------

CODE	Cu		L		L min		F _{1i} *		F _{1p} **		V ₀		~Kg	~lb	PED 2014/68/EU
	mm	inch	mm	inch	mm	inch	daN	lb	daN	lb	cm ³	in ³			
M90-007-A-...	7	0.28	56	2.20	49	1.93	1,16 x F0		1,30 x F0		-	-	0,07	0.15	✓
M90-010-A-...	10	0.39	62	2.44	52	2.05	1,19 x F0		1,36 x F0		-	-	0,07	0.15	✓
M90-013-A-...	12,7	0.50	67,4	2.65	54,7	2.15	1,22 x F0		1,40 x F0		-	-	0,08	0.18	✓
M90-015-A-...	15	0.59	72	2.83	57	2.24	1,23 x F0		1,42 x F0		-	-	0,08	0.18	✓
M90-025-A-...	25	0.98	92	3.62	67	2.64	1,28 x F0		1,50 x F0		-	-	0,09	0.20	✓
M90-038-A-...	38,1	1.50	118,2	4.65	80,1	3.15	1,31 x F0		1,55 x F0		-	-	0,11	0.24	✓
M90-050-A-...	50	1.97	142	5.59	92	3.62	1,33 x F0		1,58 x F0		-	-	0,12	0.26	✓
M90-063-A-...	63,5	2.50	172	6.77	108,5	4.27	1,33 x F0		1,57 x F0		-	-	0,14	0.31	✓
M90-080-A-...	80	3.15	205	8.07	125	4.92	1,34 x F0		1,59 x F0		-	-	0,15	0.33	✓
M90-100-A-...	100	3.94	245	9.65	145	5.71	1,35 x F0		1,61 x F0		-	-	0,17	0.37	✓
M90-125-A-...	125	4.92	295	11.61	170	6.69	1,36 x F0		1,63 x F0		-	-	0,20	0.44	✓

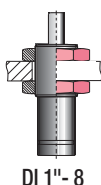

DI 1''-8

HOW TO ORDER

(10 pcs)
M90-050-A-YW-TBI

ISO 11901 - 1 B8 3180 220 000 002(MB)	VDI 3003 - Blatt 2 E24.54.815.G (PSA)	B2 4007 (BMW) 39D 878 (VW)	075.90.50 (FCA)
--	--	-------------------------------	-----------------



ACTIVE SAFETY

* F_{1i} = Isothermal end force at 100% Cu
 ** F_{1p} = Polytrophic end force at 100% Cu

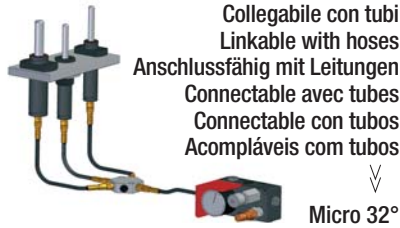

Force color code	P		F ₀ Initial force ± 5% at +20°C +68°F	
	bar	psi	daN	lb
OR	15	218	17	38
PR	25	363	28	63
GR	45	653	50	112
BU	90	1305	100	225
RD	135	1958	150	337
YW	180	2610	200	450
BK	10-180	145-2610	11-200	25-450

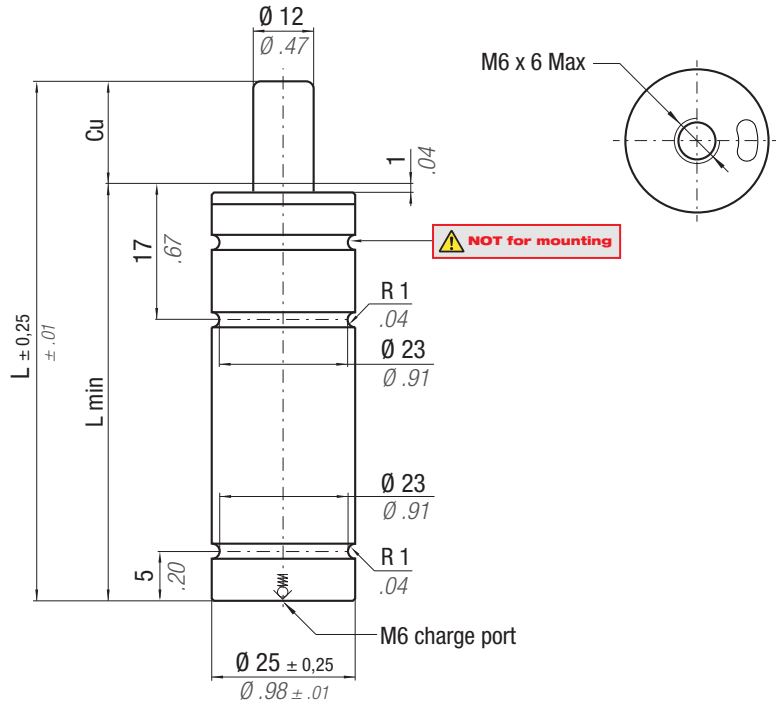

	$^{\circ}\text{F}$ 32 - 176	$^{\circ}\text{C}$ 0 - 80	ΔP $\pm 0,33\% / ^{\circ}\text{C}$	P max 180 bar 2610 psi	P min 10 bar 145 psi	S 1,13 cm ² 0,175 in ²	SPM ~ 50 - 80 (at 20°C)	Max Speed 1,8 m/s	Maintenance kit Disposable
--	--------------------------------------	------------------------------------	---	-------------------------------------	-----------------------------------	---	--------------------------------------	-----------------------------	--------------------------------------

CODE		Cu		L		L min		F _{1i} * End force *		F _{1p} ** End force **		V ₀				
		mm	inch	mm	inch	mm	inch	daN	lb	daN	lb	cm ³	in ³		~Kg	~lb
M200 - 007 - A - ...		7	0.28	56	2.20	49	1.93	1,20 x F ₀		1,35 x F ₀		-	-	0,12	0.26	✓
M200 - 010 - A - ...		10	0.39	62	2.44	52	2.05	1,24 x F ₀		1,42 x F ₀		-	-	0,13	0.29	✓
M200 - 013 - A - ...		12,7	0.50	67,4	2.65	54,7	2.15	1,27 x F ₀		1,47 x F ₀		-	-	0,13	0.29	✓
M200 - 015 - A - ...		15	0.59	72	2.83	57	2.24	1,30 x F ₀		1,50 x F ₀		-	-	0,14	0.31	✓
M200 - 016 - A - ...		16	0.63	74	2.91	58	2.28	1,30 x F ₀		1,50 x F ₀		-	-	0,14	0.31	✓
M200 - 025 - A - ...		25	0.98	92	3.62	67	2.64	1,36 x F ₀		1,60 x F ₀		-	-	0,16	0.35	✓
M200 - 038 - A - ...		38,1	1.50	118,2	4.65	80.1	3.15	1,40 x F ₀		1,67 x F ₀		-	-	0,19	0.42	✓
M200 - 050 - A - ...		50	1.97	142	5.59	92	3.62	1,42 x F ₀		1,71 x F ₀		-	-	0,20	0.44	✓
M200 - 063 - A - ...		63,5	2.50	172	6.77	108,5	4.27	1,42 x F ₀		1,70 x F ₀		-	-	0,23	0.51	✓
M200 - 080 - A - ...		80	3.15	205	8.07	125	4.92	1,43 x F ₀		1,73 x F ₀		-	-	0,26	0.57	✓
M200 - 100 - A - ...		100	3.94	245	9.65	145	5.71	1,45 x F ₀		1,75 x F ₀		-	-	0,30	0.66	✓
M200 - 125 - A - ...		125	4.92	295	11.61	170	6.69	1,46 x F ₀		1,78 x F ₀		-	-	0,34	0.75	✓

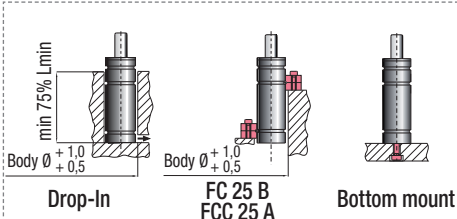

HOW TO ORDER

(10 pcs) M200-050-A-YW

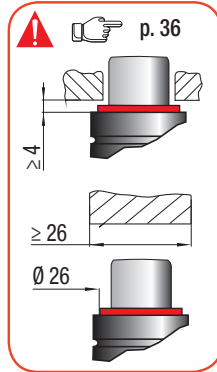
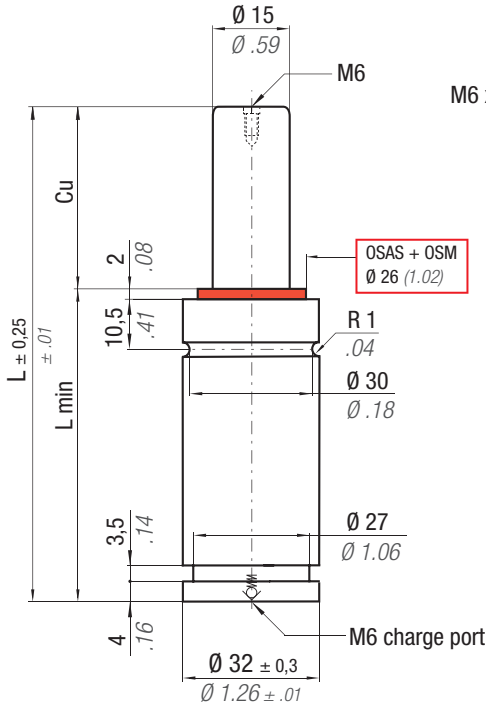

OSAS + OSM = OVER STROKE ACTIVE SAFETY + OVER STROKE MARKER

* $F_{1i} =$

Isothermal end force at 100% Cu

p. 16

** $F_{1p} =$

Polytropic end force at 100% Cu

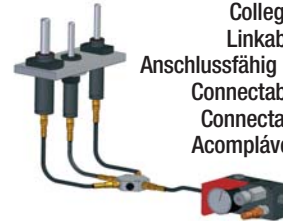

Collegabile con tubi
Linkable with hoses
Anschlussfähig mit Leitungen
Connectable with tubes
Connectable with tubos
Acompláveis com tubos

Micro 32°



ACTIVE SAFETY



OSAS



USAS

Force color code	P		Fo	
	bar	psi	Initial force $\pm 5\%$ at $+20^\circ\text{C} + 68^\circ\text{F}$	
			daN	lb
GR	45	653	80	180
BU	90	1305	160	360
RD	135	1958	240	540
YW	180	2610	320	719
BK	10-180	145-2610	18-320	40-719

	$^{\circ}\text{F}$ 32 - 176	$^{\circ}\text{C}$ 0 - 80	ΔP $\pm 0,33\% / ^{\circ}\text{C}$	P max 180 bar 2610 psi	P min 10 bar 145 psi	S 1,77 cm ² 0,274 in ²	SPM ~ 50 - 80 (at 20°C)	Max Speed 1,8 m/s	Maintenance kit 39BMMCI32A
--	--------------------------------------	------------------------------------	---	------------------------------	----------------------------	--	-------------------------------	----------------------	-------------------------------

CODE	Cu		L		L min		F _{1i} *		F _{1p} **		V ₀		~Kg	~lb	
	mm	inch	mm	inch	mm	inch	daN	lb	daN	lb	cm ³	in ³			
M300 - 007 - A - ...	7	0.28	56	2.20	49	1.93	1,17 x F ₀		1,30 x F ₀		-	-	0,21	0.01	✓
M300 - 010 - A - ...	10	0.39	62	2.44	52	2.05	1,21 x F ₀		1,37 x F ₀		-	-	0,22	0.01	✓
M300 - 013 - A - ...	12,7	0.50	67,4	2.65	54,7	2.15	1,24 x F ₀		1,41 x F ₀		-	-	0,23	0.01	✓
M300 - 015 - A - ...	15	0.59	72	2.83	57	2.24	1,26 x F ₀		1,44 x F ₀		-	-	0,24	0.01	✓
M300 - 025 - A - ...	25	0.98	92	3.62	67	2.64	1,32 x F ₀		1,53 x F ₀		-	-	0,26	0.01	✓
M300 - 038 - A - ...	38	1.50	118	4.65	80	3.15	1,36 x F ₀		1,60 x F ₀		-	-	0,30	0.01	✓
M300 - 050 - A - ...	50	1.97	142	5.59	92	3.62	1,38 x F ₀		1,64 x F ₀		-	-	0,34	0.01	✓
M300 - 063 - A - ...	63,5	2.50	172	6.77	108,5	4.27	1,38 x F ₀		1,63 x F ₀		-	-	0,39	0.02	✓
M300 - 080 - A - ...	80	3.15	205	8.07	125	4.92	1,40 x F ₀		1,66 x F ₀		-	-	0,44	0.02	✓
M300 - 100 - A - ...	100	3.94	245	9.65	145	5.71	1,41 x F ₀		1,68 x F ₀		-	-	0,50	0.02	✓
M300 - 125 - A - ...	125	4.92	295	11.61	170	6.69	1,42 x F ₀		1,70 x F ₀		-	-	0,57	0.02	✓

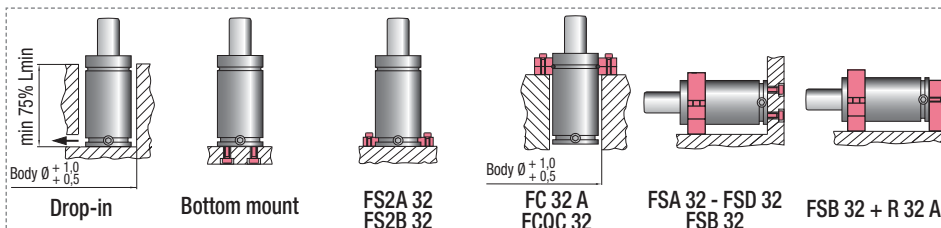

HOW TO ORDER

(10 pcs) M300-050-A-YW

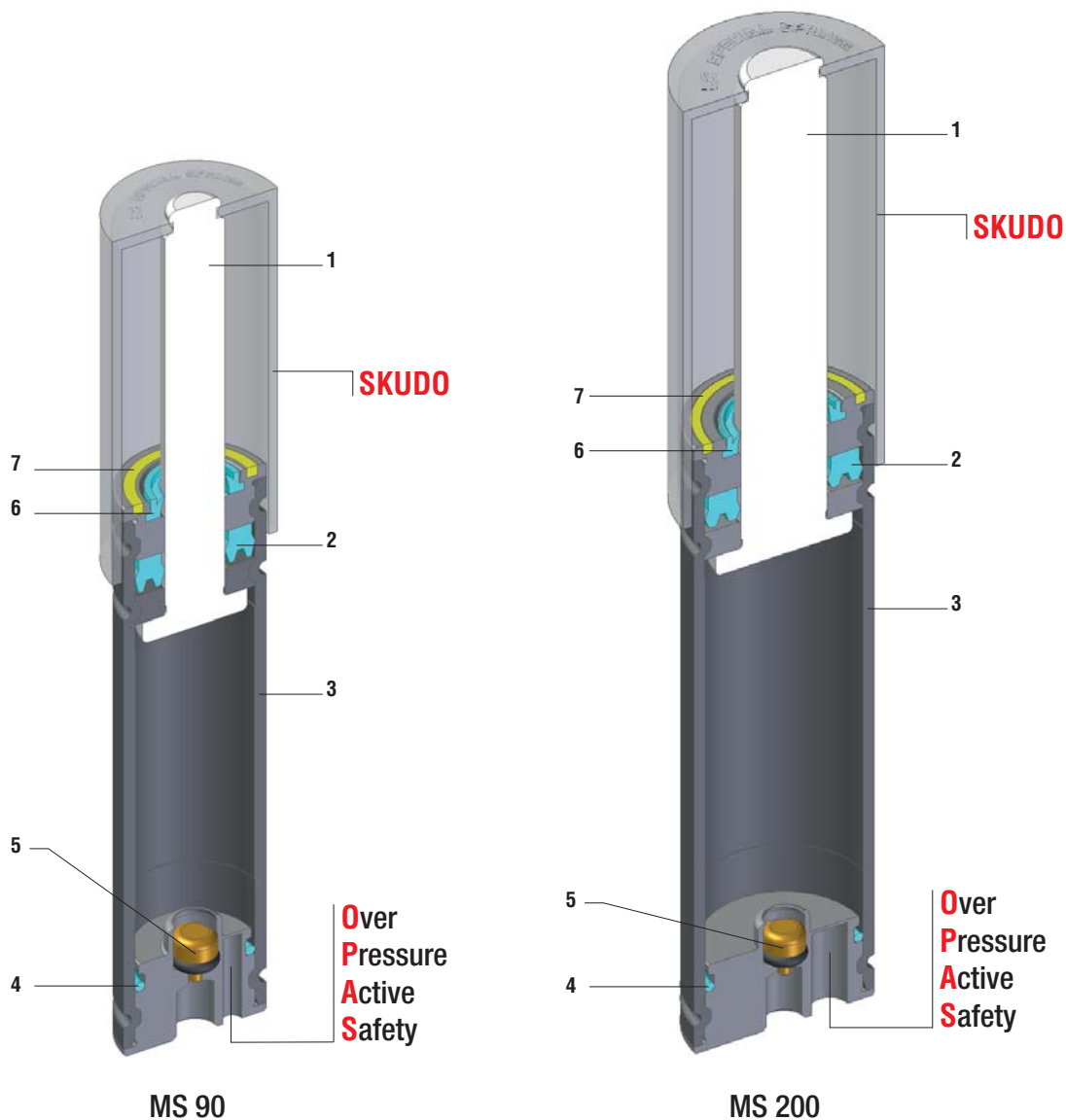





Mini cilindri - Mini cylinders - Mini Gasdruckfedern
 Mini-ressorts - Mini cilindros - Mini-cilindros

SEALING	ROD SEAL
DESIGN	RETAINING GROOVE DESIGN

1	Rod (nitrited superfinished)	5	Valve
2	Rod seal	6	Rod wiper
3	Body	7	Force color code
4	O-ring		

RANGE CHART

Model	Body Ø		Stroke Cu		Initial force F0		 OSAS	 USAS	 OPAS	 SKUDO
	mm	inch	mm	inch	daN	lb				
MS 90	19	0.75	7 - 122	0.28 - 4.80	5 - 90	11 - 202	-	-	✓	✓
MS 200	25	0.98	7 - 122	0.28 - 4.80	17 - 200	38 - 450	-	-	✓	✓

MS



HOW TO ORDER

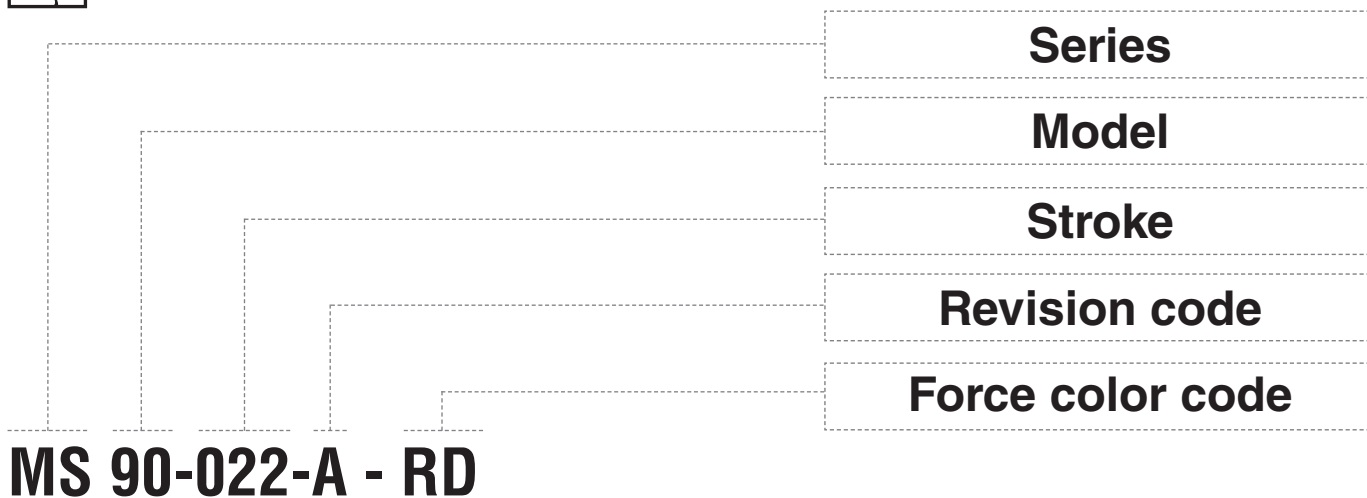

MS 90-022-A - RD

- IT** Codice cilindro autonomo
- EN** Self-contained cylinder code
- DE** Kode des eingeständigen Gdf.
- FR** Code du cylindre autonome
- ES** Código del cilindro autónomo
- PT** Codigo do cilindro autónomo

- IT** Identificazione delle forze iniziali (vedi tab. "force color code"), se non specificata, si intende sempre forza massima YW. Per forze diverse BK + Fo richiesta.
- EN** Identification of initial forces (see "force color code" chart), if not specified, it is always intended as maximum force YW. For different forces BK + Fo required
- DE** Identifikation der initiales Kräfte (siehe tabelle "force color code"), wenn nicht aufgestellt, es ist immer verstanden als maximaler Kraft YW. Für verschiedenen Kräfte, BK + Fo gebrauchte
- FR** Identifies forces initiale (voir tabelle "force color code"), si non specificé, on entend toujours force maximale YW. Pour forces différentes BK + Fo requise
- ES** Identificación de las fuerzas iniciales (veer cuadro "force color code"), si no se especifica, se entiende siempre la maxima fuerza YW. Para fuerzas diferentes BK + Fo requerida
- PT** Identificação das forças iniciais (ver Tabela "force color code"), se não especificado, é sempre entendido a maxima força YW. Para forças diferentes BK + Fo inquerita

ACTIVE SAFETY

* F_{1i} = Isothermal end force at 100% Cu p. 16 ** F_{1p} = Polytrophic end force at 100% Cu

Force color code	P		F ₀	
	bar	psi	Initial force ± 5% at +20°C +68°F	
OR	10	145	5	11
PR	20	290	10	22
GR	60	870	30	67
BU	100	1450	50	112
RD	140	2030	70	157
YW	180	2610	90	202
BK	10-180	145-2610	5-90	11-202



OPAS



SKUDO

NOT FOR

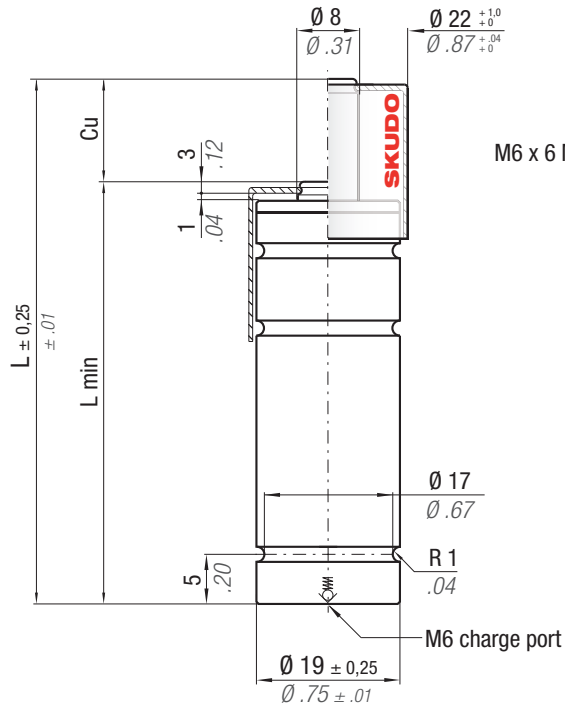
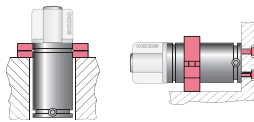

M6 x 6 Max

CODE	N ₂	°F 32 - 176	°C 0 - 80	ΔP ± 0,33 %/°C	P max 180 bar 2610 psi	P min 10 bar 145 psi	S 0,5 cm ² 0,078 in ²	SPM ~ 100 - 150 (at 20°C)	Max Speed 1,8 m/s	Maintenance kit Disposable	Cu		L		L min		F _{1i} *		F _{1p} **		V ₀		PED 2014/68/EU
											mm	inch	mm	inch	mm	inch	daN	lb	daN	lb	cm ³	in ³	
MS90 - 007 - A - ...											7	0.28	62	2.44	55	2.17	1,13 x F ₀	1,26 x F ₀	-	-	0,07	0.15	✓
MS90 - 010 - A - ...											9,7	0.38	67,4	2.65	57,7	2.27	1,16 x F ₀	1,30 x F ₀	-	-	0,08	0.18	✓
MS90 - 012 - A - ...											12	0.47	72	2.83	60	2.36	1,18 x F ₀	1,34 x F ₀	-	-	0,08	0.18	✓
MS90 - 022 - A - ...											22	0.87	92	3.62	70	2.76	1,24 x F ₀	1,43 x F ₀	-	-	0,09	0.20	✓
MS90 - 035 - A - ...											35,1	1.38	118,2	4.65	83,1	3.27	1,28 x F ₀	1,50 x F ₀	-	-	0,11	0.24	✓
MS90 - 047 - A - ...											47	1.85	142	5.59	95	3.74	1,31 x F ₀	1,54 x F ₀	-	-	0,12	0.26	✓
MS90 - 060 - A - ...											60,5	2.38	172	6.77	111,5	4.39	1,31 x F ₀	1,54 x F ₀	-	-	0,14	0.31	✓
MS90 - 077 - A - ...											77	3.03	205	8.07	128	5.04	1,32 x F ₀	1,57 x F ₀	-	-	0,15	0.33	✓
MS90 - 097 - A - ...											97	3.82	245	9.65	148	5.83	1,34 x F ₀	1,59 x F ₀	-	-	0,17	0.37	✓
MS90 - 122 - A - ...											122	4.80	295	11.61	173	6.81	1,35 x F ₀	1,61 x F ₀	-	-	0,20	0.44	✓

WARNING REMOVE SKUDO

Upside down mounting

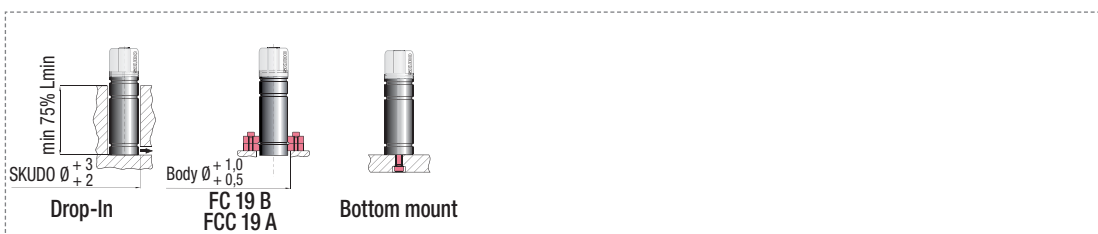

HOW TO ORDER

(10 pcs) MS90-047-A-YW

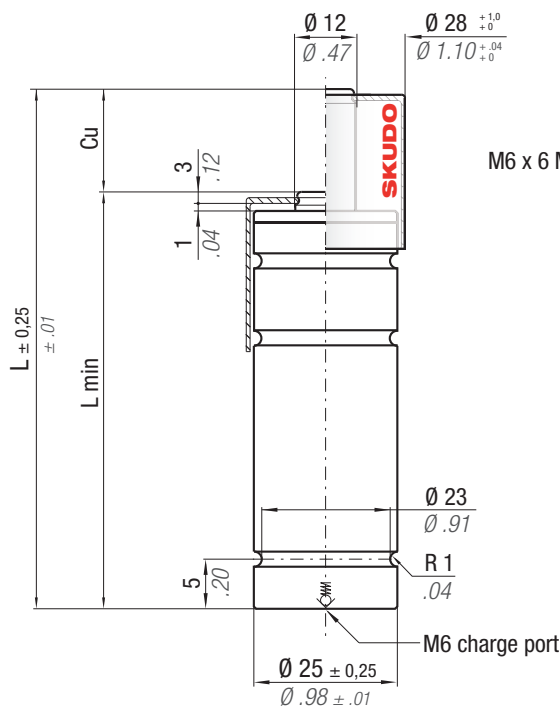

* F_{1i} = Isothermal end force at 100% Cu p. 16 ** F_{1p} = Polytrophic end force at 100% Cu

Force color code	P		F ₀	
	bar	psi	Initial force ± 5% at +20°C +68°F	
OR	15	218	17	38
PR	25	363	28	63
GR	45	653	50	112
BU	90	1305	100	225
RD	135	1958	150	337
YW	180	2610	200	450
BK	10-180	145-2610	11-200	25-450

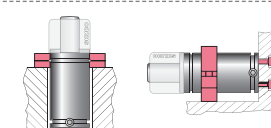

ACTIVE SAFETY



OPAS



SKUDO

MS

	°F 32 - 176	°C 0 - 80	ΔP ± 0,33 %/°C	P max 180 bar 2610 psi	P min 10 bar 145 psi	S 1,13 cm ² 0.175 in ²	SPM ~ 50 - 80 (at 20°C)	Max Speed 1,8 m/s	Maintenance kit Disposable
--	----------------------	--------------------	---------------------------	------------------------------	----------------------------	--	-------------------------------	----------------------	-------------------------------

CODE		Cu		L		L min		F _{1i} *		F _{1p} **		V ₀				
		mm	inch	mm	inch	mm	inch	daN	lb	daN	lb	cm ³	in ³			
MS200 - 007 - A		7	0.28	62	2.44	55	2.17	1,17 x F ₀		1,29 x F ₀		-	-	0,13	0.29	✓
MS200 - 010 - A		9,7	0.38	67,4	2.65	57,7	2.27	1,20 x F ₀		1,35 x F ₀		-	-	0,13	0.29	✓
MS200 - 012 - A		12	0.47	72	2.83	60	2.36	1,23 x F ₀		1,39 x F ₀		-	-	0,14	0.31	✓
MS200 - 022 - A		22	0.87	92	3.62	70	2.76	1,30 x F ₀		1,51 x F ₀		-	-	0,16	0.35	✓
MS200 - 035 - A		35,1	1.38	118,2	4.65	83,1	3.27	1,36 x F ₀		1,60 x F ₀		-	-	0,19	0.42	✓
MS200 - 047 - A		47	1.85	142	5.59	95	3.74	1,39 x F ₀		1,65 x F ₀		-	-	0,20	0.44	✓
MS200 - 060 - A		60,5	2.38	172	6.77	111,5	4.39	1,39 x F ₀		1,66 x F ₀		-	-	0,23	0.51	✓
MS200 - 077 - A		77	3.03	205	8.07	128	5.04	1,41 x F ₀		1,69 x F ₀		-	-	0,26	0.57	✓
MS200 - 097 - A		97	3.82	245	9.65	148	5.83	1,43 x F ₀		1,72 x F ₀		-	-	0,30	0.66	✓
MS200 - 122 - A		122	4.80	295	11.61	173	6.81	1,45 x F ₀		1,75 x F ₀		-	-	0,34	0.75	✓

WARNING REMOVE SKUDO

Upside down mounting

Drop-In

FC 25 B
FCC 25 A

Bottom mount

HOW TO ORDER

(10 pcs) MS200-047-A-YW

ISO	VDI	BMW	FCA
Ford	Mazda	MB	Nissan
PSA	VW		

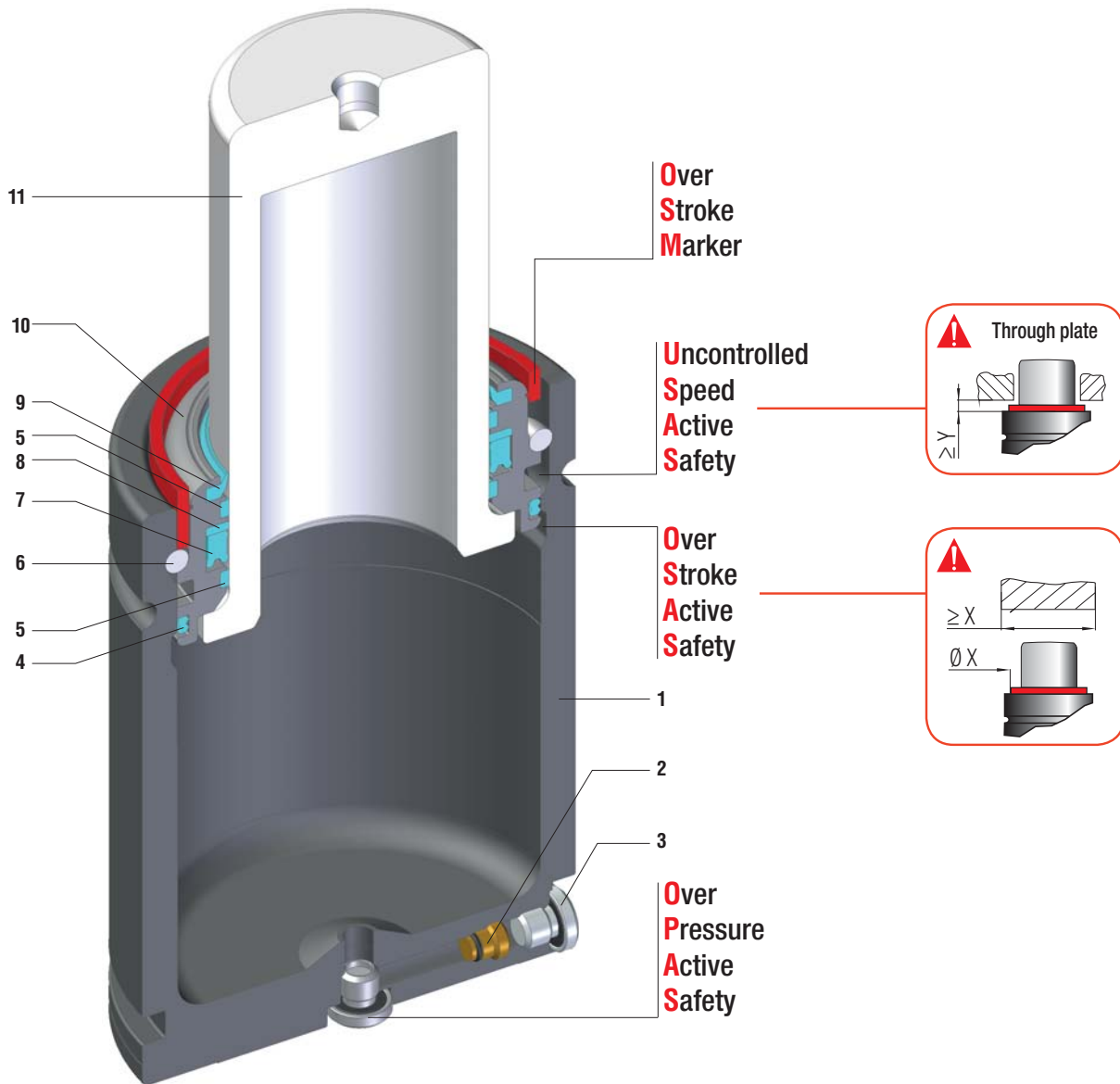

Minima altezza, massima forza - Minimum height, maximum force - Minimale Höhe, maximale Kraft
 Hauteur minimale, force maximale - Mínima altura, máxima fuerza - Altura mínima, força máxima

SEALING	ROD SEAL
DESIGN	BUSH - BODY DESIGN

1	Body	5	Guide ring	9	Rod wiper
2	Valve	6	Retaining ring	10	Bush
3	Plug	7	Rod seal	11	Rod (nitrited superfinished)
4	Dual ring seal	8	Back-up ring		

RANGE CHART

Model	Body Ø		Stroke Cu		Initial force F0					
	mm	inch	mm	inch	daN	lb				
RV 170	19	0.75	7 - 125	0.28 - 4.92	170	382	-	-	✓	-
RV 320	25	0.98	7 - 125	0.28 - 4.92	320	719	-	-	✓	-
RV 350	32	1.26	10 - 125	0.39 - 4.92	360	809	✓	✓	✓	-
RV 500	38	1.50	10 - 125	0.39 - 4.92	470	1057	✓	✓	✓	-
RV 750	45	1.77	10 - 125	0.39 - 4.92	740	1664	✓	✓	✓	-
RV 1000	50	1.97	10 - 125	0.39 - 4.92	920	2068	✓	✓	✓	-
RV 1200	50	1.97	10 - 125	0.39 - 4.92	1060	2383	✓	✓	✓	-
RV 1500	63	2.48	10 - 125	0.39 - 4.92	1530	3440	✓	✓	✓	-
RV 2400	75	2.95	10 - 125	0.39 - 4.92	2385	5362	✓	✓	✓	-
RV 4200	95	3.74	16 - 125	0.63 - 4.92	4240	9532	✓	✓	✓	-
RV 6600	120	4.72	16 - 125	0.63 - 4.92	6630	14905	✓	✓	✓	-
RV 9500	150	5.91	19 - 125	0.75 - 4.92	9540	21447	✓	✓	✓	-
RV 12000	150	5.91	19 - 125	0.75 - 4.92	11780	26470	✓	✓	✓	-
RV 20000	195	7.68	19 - 125	0.75 - 4.92	19910	44738	✓	✓	✓	-

RV

HOW TO ORDER



RV 2400-050-A - N - E - EV

- IT** Codice cilindro autonomo
- EN** Self-contained cylinder code
- DE** Kode des eingeständigen Gdf.
- FR** Code du cylindre autonome
- ES** Código del cilindro autónomo
- PT** Código do cilindro autónomo

- IT** Collegabile con tubi, cilindro fornito scarico e senza valvola unidirezionale
- EN** Linkable with hoses, cylinder supplied without pressure and oneway valve
- DE** Anschlussfähig mit Leitungen, Gdf. geliefert ohne Druck und RückschlagVentil
- FR** Connectable avec tubes, ressort fourni sans pression ni valve unidirectionelle
- ES** Connectable con tubos, cilindro suministrado sin presión y sin válvula unidireccional
- PT** Acompláveis com tubos, cilindro fornecidos sem pressão e sem válvula unidireccional

- IT** Collegabile EASY MANIFOLD, fornito scarico + guarnizione di collegamento
- EN** Linkable EASY MANIFOLD, supplied without pressure + connecting seal
- DE** Anschlussfähig EASY MANIFOLD, geliefert ohne Druck + Verbindungsdichtung
- FR** Connectable EASY MANIFOLD, fourni sans pression + joint de connexion
- ES** Connectable EASY MANIFOLD, suministrado sin presión + junta de conexión
- PT** Acompláveis EASY MANIFOLD, fornecidos sem pressão + vedantes de conexão

ISO 11901 - 3 B8 3180 220 000 004(MB)	VDI 3003 - Blatt 3 39D 997 (VW)	B2 4005 (BMW)	075.90.60 (FCA)
--	------------------------------------	---------------	-----------------



ACTIVE SAFETY

Il nuovo codice sarà fornito solo ad esaurimento del vecchio

The new code will be supplied only when the old will be out of stock

Der neue Kode wird geliefert nur wenn der alte nicht mehr im Lager ist

Le nouveau code sera fourni uniquement lorsque le vieux stock sera écoulé

El nuevo código será suministrado sólo cuando el viejo está fuera de stock

O novo código irá ser fornecido apenas quando o antigo esgotar stock

* $F_{1i} =$ Isothermal end force at 100% Cu p. 16 ** $F_{1p} =$ Polytrophic end force at 100% Cu



OPAS

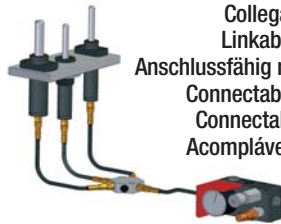

Collegabile con tubi
Linkable with hoses
Anschlussfähig mit Leitungen
Connectable avec tubes
Connectable con tubos
Acompláveis com tubos

Micro 32°

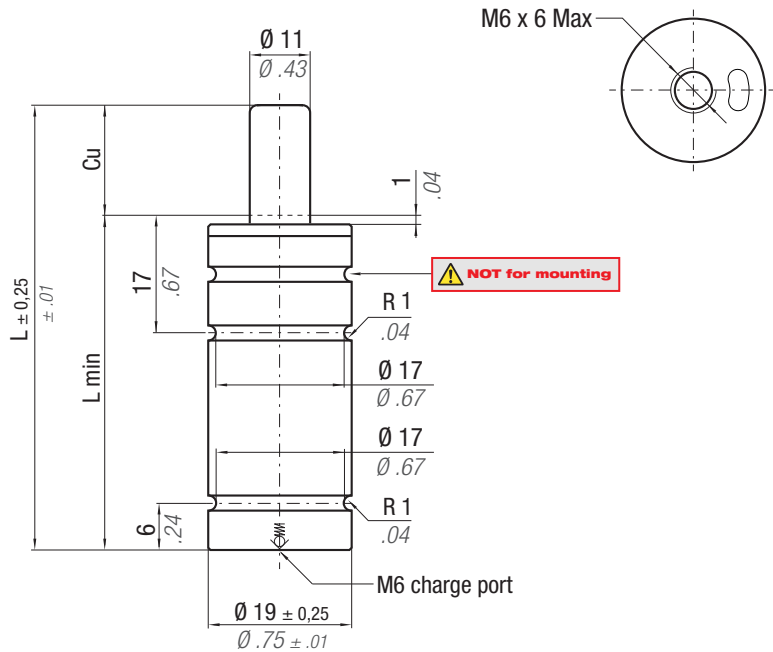

N ₂	°F 32 - 176	°C 0 - 80	ΔP ± 0,33 %/°C	P max 180 bar 2610 psi	P min 20 bar 290 psi	S 0,95 cm ² 0,147 in ²	SPM ~ 40 - 100 (at 20°C)	Max Speed 1,8 m/s	Maintenance kit Disposable
----------------	----------------------	--------------------	---------------------------	------------------------------	----------------------------	--	--------------------------------	----------------------	-------------------------------

CODE PHASING OUT from 09/2013	NEW	Cu		L		L min		F ₀ Initial force		F _{1i} * End force *		F _{1p} ** End force **		V ₀		PED 2014/68/EU		
		mm	inch	mm	inch	mm	inch	daN	lb	daN	lb	daN	lb	cm ³	in ³		~Kg	~lb
RV 170 - 007 - A	RV 170 - 007 - B	7	0.28	44	1.73	37	1.46	170 382 ± 5% 180 bar 2610psi + 20 °C +68 °F	382	256	576	295	663	2,0	0.12	0,06	0.13	✓
RV 170 - 010 - A	RV 170 - 010 - B	10	0.39	50	1.97	40	1.57			270	607	315	707	3,0	0.18	0,06	0.13	✓
RV 170 - 013 - A	RV 170 - 013 - B	13	0.51	56	2.20	43	1.69			279	628	328	738	4,0	0.24	0,07	0.15	✓
RV 170 - 015 - A	RV 170 - 015 - B	15	0.59	60	2.36	45	1.77			284	638	335	753	4,0	0.24	0,07	0.15	✓
RV 170 - 019 - A	RV 170 - 019 - B	19	0.75	68	2.68	49	1.93			291	654	346	777	5,0	0.31	0,07	0.16	✓
RV 170 - 025 - A	RV 170 - 025 - B	25	0.98	80	3.15	55	2.17			298	670	356	801	7,0	0.43	0,08	0.17	✓
RV 170 - 032 - A	RV 170 - 032 - B	32	1.26	94	3.7	62	2.44			304	683	365	820	8,0	0.49	0,09	0.19	✓
RV 170 - 038 - A	RV 170 - 038 - B	38	1.5	106	4.17	68	2.68			307	690	370	831	10,0	0.61	0,09	0.20	✓
RV 170 - 050 - A	RV 170 - 050 - B	50	1.97	130	5.12	80	3.15			312	700	376	846	13,0	0.79	0,11	0.23	✓
RV 170 - 063 - A	RV 170 - 063 - B	63	2.48	156	6.14	93	3.66			315	707	381	857	16,0	0.98	0,12	0.26	✓
RV 170 - 075 - A	RV 170 - 075 - B	75	2.95	185	7.28	110	4.33			304	684	366	822	19,0	1.16	0,14	0.30	✓
RV 170 - 080 - A	RV 170 - 080 - B	80	3.15	195	7.68	115	4.53			306	687	368	826	21,0	1.28	0,14	0.31	✓
RV 170 - 100 - A	RV 170 - 100 - B	100	3.94	235	9.25	135	5.31			310	696	373	840	25,0	1.55	0,16	0.36	✓
RV 170 - 125 - A	RV 170 - 125 - B	125	4.92	285	11.22	160	6.3			313	703	379	851	31,0	1.91	0,19	0.42	✓

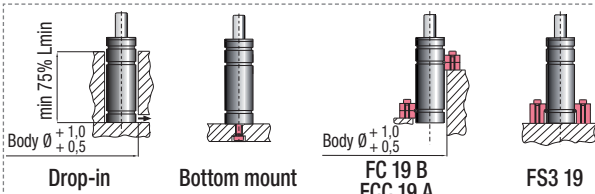

HOW TO ORDER

(10 pcs) RV 170-050-B



ACTIVE SAFETY



OPAS

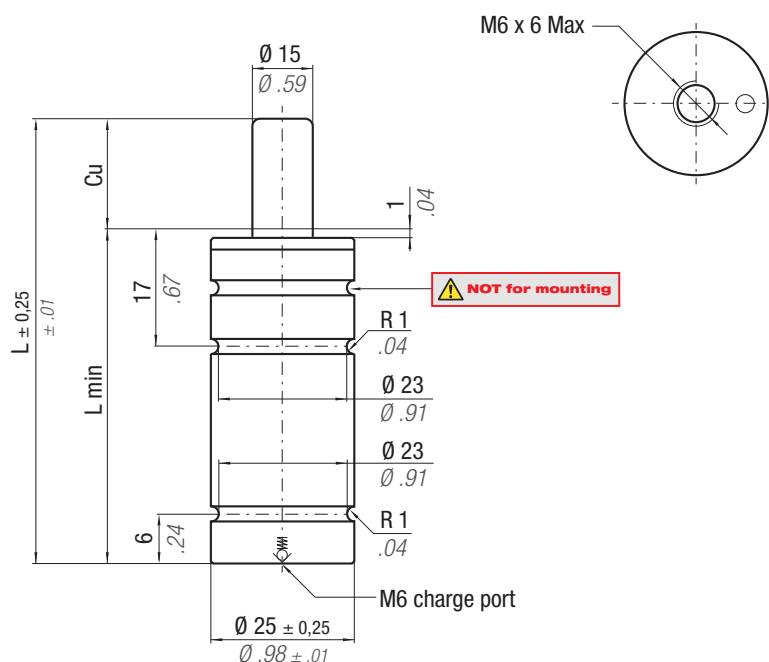

Il nuovo codice sarà fornito solo ad esaurimento del vecchio

The new code will be supplied only when the old will be out of stock

Der neue Kode wird geliefert nur wenn der alte nicht mehr im Lager ist

Le nouveau code sera fourni uniquement lorsque le vieux stock sera écoulé

El nuevo código será suministrado sólo cuando el viejo está fuera de stock

O novo código irá ser fornecido apenas quando o antigo esgotar stock

* $F_{1i} =$

Isothermal end force at 100% Cu



p. 16

** $F_{1p} =$

Polytropic end force at 100% Cu

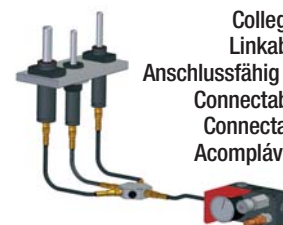

Collegabile con tubi
Linkable with hoses
Anschlussfähig mit Leitungen
Connectable avec tubes
Connectable con tubos
Acompláveis com tubos

Micro 32°

	$^{\circ}\text{F}$ 32 - 176	$^{\circ}\text{C}$ 0 - 80	ΔP $\pm 0,33\% / ^{\circ}\text{C}$	P max 180 bar 2610 psi	P min 20 bar 290 psi	S 1,77 cm ² 0.27 in ²	SPM ~ 40 - 100 (at 20°C)	Max Speed 1,8 m/s	Maintenance kit Disposable
--	--------------------------------------	------------------------------------	---	-------------------------------------	-----------------------------------	--	---------------------------------------	-----------------------------	--------------------------------------

CODE PHASING OUT from 09/2013	NEW	Cu		L		L min		F0 Initial force		F _{1i} * End force *		F _{1p} ** End force **		V0		PED 2014/68/EU		
		mm	inch	mm	inch	mm	inch	daN	lb	daN	lb	daN	lb	cm ³	in ³	~Kg	~lb	✓
RV 320 - 007 - A	RV 320 - 007 - B	7	0.28	44	1.73	37	1.46	320 719 ± 5% 180 bar 2610psi + 20 °C +68 °F		465	1045	531	1194	5,0	0.31	0,10	0.22	✓
RV 320 - 010 - A	RV 320 - 010 - B	10	0.39	50	1.97	40	1.57			489	1098	566	1272	6,0	0.37	0,10	0.23	✓
RV 320 - 013 - A	RV 320 - 013 - B	13	0.51	56	2.20	43	1.69			505	1135	589	1324	8,0	0.49	0,11	0.24	✓
RV 320 - 015 - A	RV 320 - 015 - B	15	0.59	60	2.36	45	1.77			513	1154	602	1353	8,0	0.49	0,11	0.24	✓
RV 320 - 019 - A	RV 320 - 019 - B	19	0.75	68	2.68	49	1.93			526	1183	620	1394	10,0	0.61	0,12	0.26	✓
RV 320 - 025 - A	RV 320 - 025 - B	25	0.98	80	3.15	55	2.17			539	1212	640	1439	13,0	0.79	0,13	0.28	✓
RV 320 - 032 - A	RV 320 - 032 - B	32	1.26	94	3.70	62	2.44			549	1234	654	1470	16,0	0.98	0,14	0.31	✓
RV 320 - 038 - A	RV 320 - 038 - B	38	1.50	106	4.17	68	2.68			555	1248	663	1490	19,0	1.16	0,15	0.33	✓
RV 320 - 050 - A	RV 320 - 050 - B	50	1.97	130	5.12	80	3.15			563	1266	676	1520	24,0	1.46	0,17	0.37	✓
RV 320 - 063 - A	RV 320 - 063 - B	63	2.48	156	6.14	93	3.66			569	1279	684	1538	30,0	1.83	0,19	0.42	✓
RV 320 - 075 - A	RV 320 - 075 - B	75	2.95	185	7.28	110	4.33			552	1240	658	1479	38,0	2.32	0,22	0.48	✓
RV 320 - 080 - A	RV 320 - 080 - B	80	3.15	195	7.68	115	4.53			554	1245	662	1488	40,0	2.44	0,23	0.50	✓
RV 320 - 100 - A	RV 320 - 100 - B	100	3.94	235	9.25	135	5.31			561	1261	672	1511	49,0	2.99	0,26	0.57	✓
RV 320 - 125 - A	RV 320 - 125 - B	125	4.92	285	11.22	160	6.30			567	1274	681	1531	60,0	4.08	0,30	0.66	✓

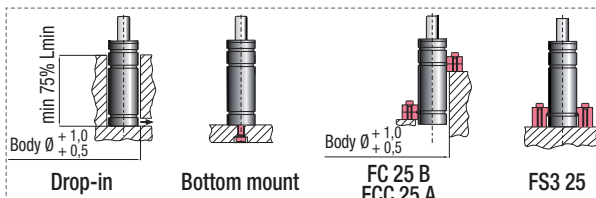

HOW TO ORDER

(10 pcs) RV 320-050-B

RV 350

ISO 11901 - 3	VDI 3003 - Blatt 3	B2 4005 (BMW)	075.90.60 (FCA)
W-DX35-6204 (Ford)	B8 3180 220 000 004(MB)	39D 997 (VW)	



OSAS + OSM = OVER STROKE ACTIVE SAFETY + OVER STROKE MARKER

ACTIVE SAFETY

easyl MANIFOLD p. 211



OSAS

* F_{1i} = Isothermal end force at 100% Cu p. 16

** F_{1p} = Polytropic end force at 100% Cu



USAS



OPAS

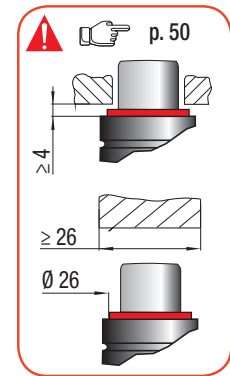
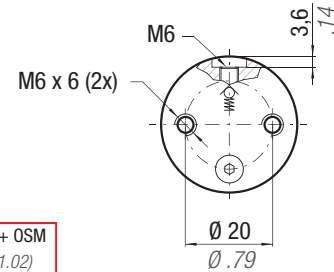
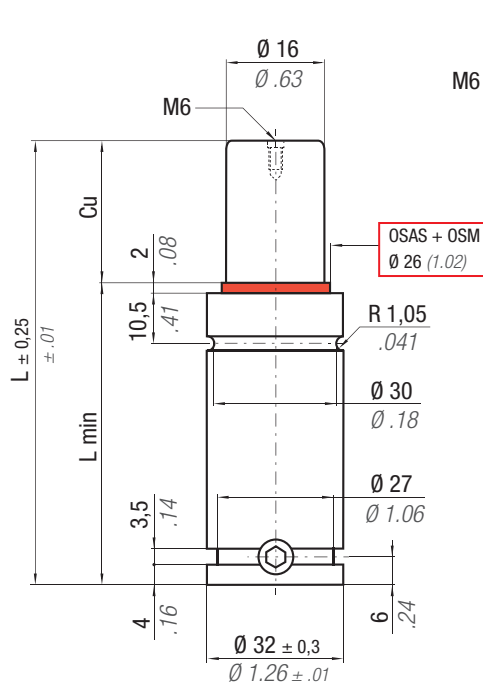

	°F 32 - 176	°C 0 - 80	ΔP ± 0,33 %/°C	P max 180 bar 2610 psi	P min 20 bar 290 psi	S 2,01 cm ² 0,312 in ²	SPM ~ 20 - 100 (at 20°C)	Max Speed 1,8 m/s	Maintenance kit 39BMRV00350C
--	----------------------	--------------------	---------------------------	-------------------------------------	-----------------------------------	---	---------------------------------------	-----------------------------	--

CODE	Cu		L		L min		F ₀		F _{1i} *		F _{1p} **		V ₀		PED		
	mm	inch	mm	inch	mm	inch	daN	lb	daN	lb	daN	lb	cm ³	in ³	~Kg	~lb	
RV 350 - 010 - A	10	0.39	50	1.97	40	1.57	360 809 ± 5%		524	1179	598	1345	8,0	0.49	0,17	0.36	✓
RV 350 - 013 - A	13	0.51	56	2.20	43	1.69			538	1209	617	1388	10,0	0.61	0,18	0.39	✓
RV 350 - 016 - A	16	0.63	62	2.44	46	1.81			547	1231	631	1419	12,0	0.73	0,19	0.41	✓
RV 350 - 019 - A	19	0.75	68	2.68	49	1.93			555	1247	642	1442	13,0	0.79	0,19	0.43	✓
RV 350 - 025 - A	25	0.98	80	3.15	55	2.17			565	1269	656	1475	17,0	1.04	0,21	0.47	✓
RV 350 - 032 - A	32	1.26	94	3.70	62	2.44			572	1286	667	1500	21,0	1.28	0,24	0.52	✓
RV 350 - 038 - A	38	1.50	106	4.17	68	2.68			577	1297	674	1515	25,0	1.53	0,26	0.56	✓
RV 350 - 050 - A	50	1.97	130	5.12	80	3.15			583	1310	683	1535	32,0	1.95	0,30	0.65	✓
RV 350 - 063 - A	63	2.48	156	6.14	93	3.66			587	1320	689	1549	40,0	2.44	0,34	0.74	✓
RV 350 - 075 - A	75	2.95	180	7.09	105	4.13			590	1326	693	1557	47,0	2.87	0,38	0.83	✓
RV 350 - 080 - A	80	3.15	190	7.48	110	4.33	591	1328	694	1560	50,0	3.05	0,39	0.86	✓		
RV 350 - 100 - A	100	3.94	230	9.06	130	5.12	593	1334	698	1569	62,0	3.78	0,46	1.01	✓		
RV 350 - 125 - A	125	4.92	280	11.02	155	6.10	595	1338	701	1576	77,0	4.70	0,54	1.18	✓		

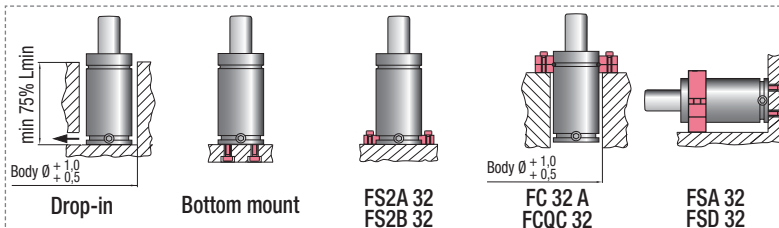

HOW TO ORDER
(10 pcs) RV 350-050-A
(10 pcs) RV 350-050-A-N

ISO 11901 - 3 W-DX35-6204 (Ford) 39D 997 (VW)	VDI 3003 - Blatt 3 B8 3180 220 000 004(MB)	B2 4005 (BMW) K 32 H (Nissan)	075.90.60 (FCA) E24.54.815.G (PSA)
---	---	----------------------------------	---------------------------------------

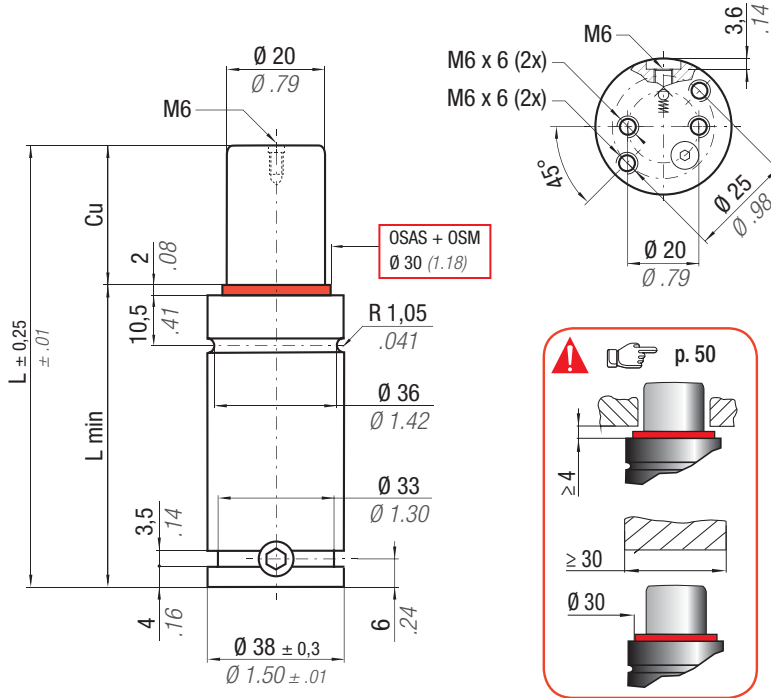

OSAS + OSM = OVER STROKE ACTIVE SAFETY + OVER STROKE MARKER

easu MANIFOLD p. 211

* F_{1i} =

Isothermal end force at 100% Cu

p. 16

** F_{1p} =

Polytrophic end force at 100% Cu



ACTIVE SAFETY



OSAS



USAS



OPAS

RV

	°F 32 - 176 °C 0 - 80	ΔP ± 0,33 %/°C	P max 150 bar 2175 psi	P min 20 bar 290 psi	S 3,14 cm ² 0.487 in ²	SPM ~ 20 - 100 (at 20°C)	Max Speed 1,8 m/s	Maintenance kit 39BMRV00500C
--	--------------------------	---------------------------	-------------------------------------	-----------------------------------	---	---------------------------------------	-----------------------------	--

CODE	Cu		L		L min		F ₀ Initial force		F _{1i} * End force *		F _{1p} ** End force **		V ₀		PED 2014/68/EU		
	mm	inch	mm	inch	mm	inch	daN	lb	daN	lb	daN	lb	cm ³	in ³	~Kg	~lb	✓
RV 500 - 010 - A	10	0.39	50	1.97	40	1.57			693	1559	824	1852	11,0	0.67	0,27	0.60	✓
RV 500 - 013 - A	13	0.51	56	2.20	43	1.69			713	1602	854	1920	14,0	0.85	0,25	0.55	✓
RV 500 - 016 - A	16	0.63	62	2.44	46	1.81			726	1633	876	1969	17,0	1.04	0,26	0.57	✓
RV 500 - 019 - A	19	0.75	68	2.68	49	1.93			736	1656	892	2005	19,0	1.16	0,28	0.62	✓
RV 500 - 025 - A	25	0.98	80	3.15	55	2.17			751	1688	916	2059	24,0	1.46	0,31	0.68	✓
RV 500 - 032 - A	32	1.26	94	3.70	62	2.44	470	1057	762	1713	933	2097	30,0	1.83	0,34	0.75	✓
RV 500 - 038 - A	38	1.50	106	4.17	68	2.68	± 5%		768	1727	944	2122	35,0	2.14	0,37	0.82	✓
RV 500 - 050 - A	50	1.97	130	5.12	80	3.15	150 bar	2175psi	777	1747	958	2154	46,0	2.81	0,43	0.95	✓
RV 500 - 063 - A	63	2.48	156	6.14	93	3.66			783	1761	968	2176	57,0	3.48	0,49	1.08	✓
RV 500 - 075 - A	75	2.95	180	7.09	105	4.13			787	1769	975	2192	67,0	4.09	0,54	1.19	✓
RV 500 - 080 - A	80	3.15	190	7.48	110	4.33	+ 20 °C	+68 °F	788	1772	977	2196	72,0	4.39	0,57	1.26	✓
RV 500 - 100 - A	100	3.94	230	9.06	130	5.12			792	1781	983	2210	89,0	5.43	0,66	1.46	✓
RV 500 - 125 - A	125	4.92	280	11.02	155	6.10			795	1788	989	2223	110,0	6.71	0,78	1.72	✓

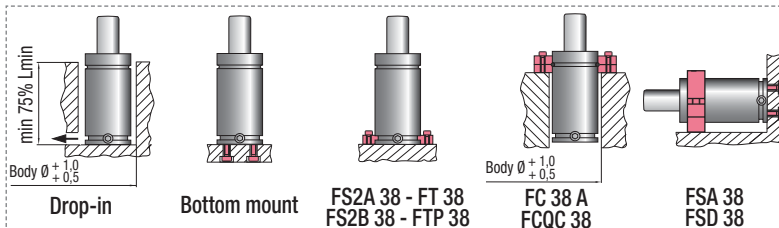

HOW TO ORDER

(10 pcs) RV 500-050-A
(10 pcs) RV 500-050-A-N

RV 750

ISO 11901 - 3 B8 3180 220 000 004(MB)	VDI 3003 - Blatt 3 E24.54.815.G (PSA)	B2 4005 (BMW) 39D 997 (VW)	W-DX35-6204 (Ford)
--	--	-------------------------------	--------------------



OSAS + OSM = OVER STROKE ACTIVE SAFETY + OVER STROKE MARKER

ACTIVE SAFETY

easq MANIFOLD p. 211



OSAS

* F_{1i} = Isothermal end force at 100% Cu p. 16

** F_{1p} = Polytropic end force at 100% Cu



USAS



OPAS

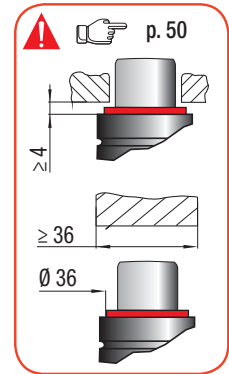
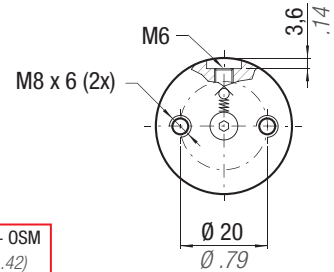
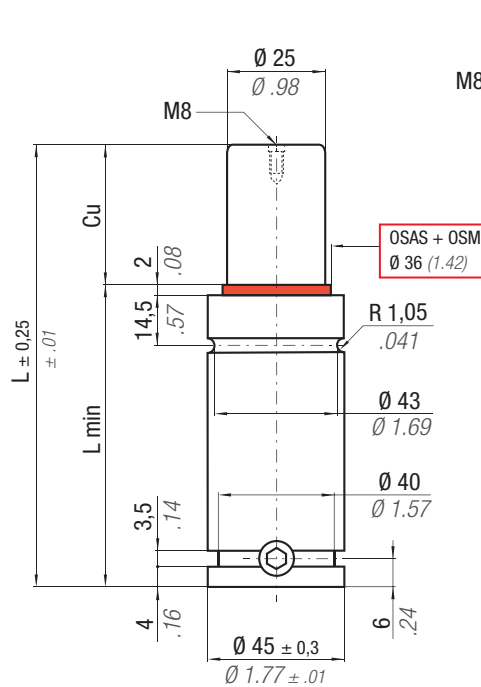

	°F 32 - 176	°C 0 - 80	ΔP ± 0,33 %/°C	P max 150 bar 2175 psi	P min 20 bar 290 psi	S 4,91 cm ² 0,761 in ²	SPM ~ 20 - 100 (at 20°C)	Max Speed 1,8 m/s	Maintenance kit 39BMRV00750C
--	----------------------	--------------------	---------------------------	-------------------------------------	-----------------------------------	---	---------------------------------------	-----------------------------	--

CODE	Cu		L		L min		F ₀		F _{1i} *		F _{1p} **		V ₀		PED		
	mm	inch	mm	inch	mm	inch	daN	lb	daN	lb	daN	lb	cm ³	in ³	~Kg	~lb	2014/68/EU
RV 750 - 010 - A	10	0.39	52	2.05	42	1.65	740 ± 5% 150 bar 2175psi + 20 °C +68 °F		1091	2452	1298	2918	18,0	1.10	0,36	0,79	✓
RV 750 - 013 - A	13	0.51	58	2.28	45	1.77			1125	2530	1354	3044	21,0	1.28	0,38	0,84	✓
RV 750 - 016 - A	16	0.63	64	2.52	48	1.89			1151	2587	1395	3136	25,0	1.53	0,40	0,88	✓
RV 750 - 019 - A	19	0.75	70	2.76	51	2.01			1170	2631	1426	3206	29,0	1.77	0,42	0,93	✓
RV 750 - 025 - A	25	0.98	82	3.23	57	2.24			1198	2694	1471	3307	37,0	2.26	0,45	0,99	✓
RV 750 - 032 - A	32	1.26	96	3.78	64	2.52			1220	2742	1506	3386	46,0	2.81	0,50	1.10	✓
RV 750 - 038 - A	38	1.50	108	4.25	70	2.76			1232	2771	1527	3433	53,0	3.23	0,54	1.19	✓
RV 750 - 050 - A	50	1.97	132	5.20	82	3.23			1250	2810	1556	3498	68,0	4.15	0,61	1.34	✓
RV 750 - 063 - A	63	2.48	158	6.22	95	3.74			1262	2838	1577	3545	85,0	5.19	0,70	1.54	✓
RV 750 - 075 - A	75	2.95	182	7.17	107	4.21			1270	2855	1590	3574	100,0	6.10	0,78	1.72	✓
RV 750 - 080 - A	80	3.15	192	7.56	112	4.41			1273	2861	1594	3583	107,0	6.53	0,81	1.79	✓
RV 750 - 100 - A	100	3.94	232	9.13	132	5.20			1281	2879	1607	3613	132,0	8.05	0,94	2.07	✓
RV 750 - 125 - A	125	4.92	282	11.10	157	6.18			1287	2894	1618	3637	164,0	10.00	1,10	2.43	✓

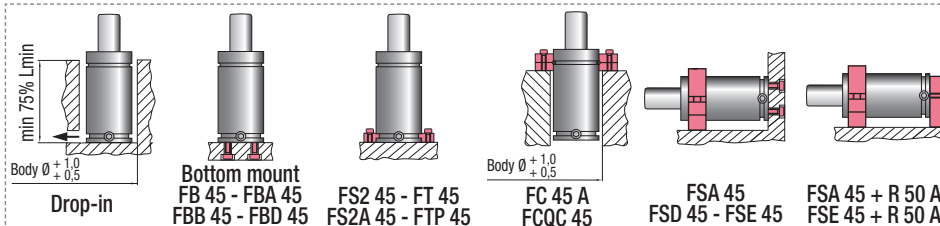

HOW TO ORDER

(10 pcs) RV 750-050-A
(10 pcs) RV 750-050-A-N

ISO 11901 - 3 B8 3180 220 000 004(MB)	VDI 3003 - Blatt 3 E24.54.815.G (PSA)	B2 4005 (BMW) 39D 997 (VW)	W-DX35-6204 (Ford)
--	--	-------------------------------	--------------------

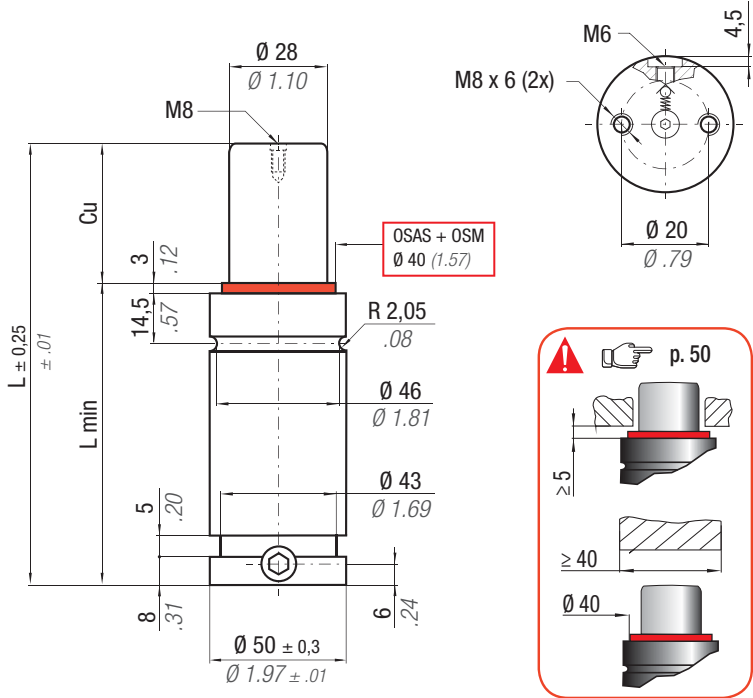

OSAS + OSM = OVER STROKE ACTIVE SAFETY + OVER STROKE MARKER



easli MANIFOLD p. 211

* F_{1i} = Isothermal end force at 100% Cu p. 16
 ** F_{1p} = Polytrophic end force at 100% Cu

ACTIVE SAFETY



OSAS



USAS



OPAS

RV

	$^{\circ}\text{F}$ 32 - 176	$^{\circ}\text{C}$ 0 - 80	ΔP $\pm 0,33\% / ^{\circ}\text{C}$	P max 150 bar 2175 psi	P min 20 bar 290 psi	S 6,15 cm ² 0.953 in ²	SPM ~ 20 - 100 (at 20°C)	Max Speed 1,8 m/s	Maintenance kit 39BMRV01000C
--	--------------------------------------	------------------------------------	---	-------------------------------------	-----------------------------------	---	---------------------------------------	-----------------------------	--

CODE	Cu		L		L min		F ₀		F _{1i} *		F _{1p} **		V ₀		PED		
	mm	inch	mm	inch	mm	inch	daN	lb	daN	lb	daN	lb	cm ³	in ³	~Kg	~lb	2014/68/EU
RV 1000 - 010 - A	10	0.39	58	2.28	48	1.89	920 ± 5%	2068	1300	2923	1523	3424	25,0	1.53	0,49	1.08	✓
RV 1000 - 013 - A	13	0.51	64	2.52	51	2.01			1349	3033	1599	3595	29,0	1.77	0,51	1.12	✓
RV 1000 - 016 - A	16	0.63	70	2.76	54	2.13			1386	3117	1658	3727	34,0	2.07	0,54	1.19	✓
RV 1000 - 019 - A	19	0.75	76	2.99	57	2.24			1416	3183	1705	3833	39,0	2.38	0,56	1.23	✓
RV 1000 - 025 - A	25	0.98	88	3.46	63	2.48			1460	3282	1775	3990	48,0	2.93	0,61	1.34	✓
RV 1000 - 032 - A	32	1.26	102	4.02	70	2.76			1495	3361	1832	4118	59,0	3.60	0,67	1.48	✓
RV 1000 - 038 - A	38	1.50	114	4.49	76	2.99			1517	3410	1868	4199	69,0	4.21	0,72	1.59	✓
RV 1000 - 050 - A	50	1.97	138	5.43	88	3.46			1548	3479	1919	4314	88,0	5.37	0,81	1.79	✓
RV 1000 - 063 - A	63	2.48	164	6.46	101	3.98			1570	3528	1955	4395	108,0	6.59	0,92	2.03	✓
RV 1000 - 075 - A	75	2.95	188	7.40	113	4.45			1584	3560	1978	4447	127,0	7.75	1,01	2.23	✓
RV 1000 - 080 - A	80	3.15	198	7.80	118	4.65	1589	3571	1986	4465	135,0	8.24	1,05	2.31	✓		
RV 1000 - 100 - A	100	3.94	238	9.37	138	5.43	1603	3604	2011	4521	166,0	10.13	1,21	2.67	✓		
RV 1000 - 125 - A	125	4.92	288	11.34	163	6.42	1616	3632	2031	4566	205,0	12.51	1,41	3.11	✓		

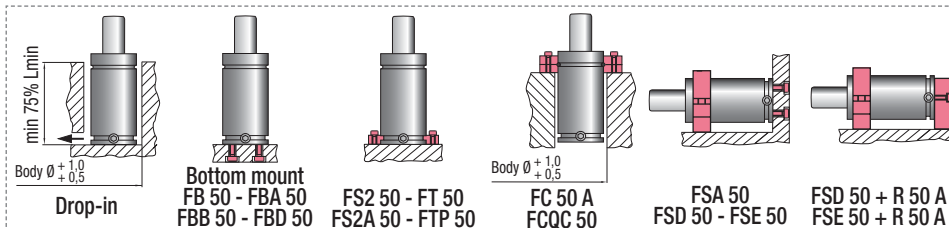

HOW TO ORDER

(10 pcs) RV 1000-050-A
 (10 pcs) RV 1000-050-A-N



OSAS + OSM = OVER STROKE ACTIVE SAFETY + OVER STROKE MARKER

ACTIVE SAFETY

easyl MANIFOLD p. 211



OSAS

* F_{1i} = Isothermal end force at 100% Cu p. 16

** F_{1p} = Polytrophic end force at 100% Cu



USAS



OPAS

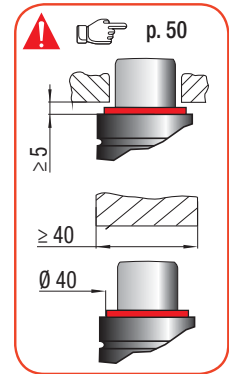
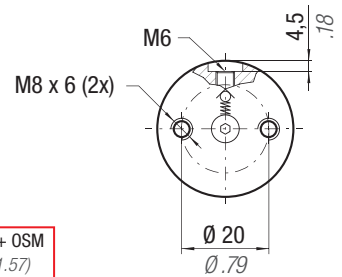
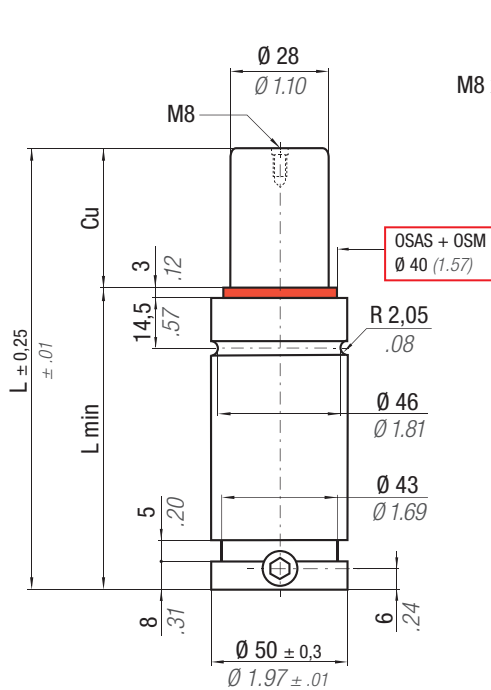

CODE		°F 32 - 176	°C 0 - 80	ΔP ± 0,33 %/°C	P max 170 bar 2465 psi	P min 20 bar 290 psi	S 6,15 cm ² 0,953 in ²	SPM ~ 20 - 100 (at 20°C)	Max Speed 1,8 m/s	Maintenance kit 39BMRV01000C	PED								
											2014/68/EU	✓							
RV 1200 - 010 - A	10	0.39	58	2.28	48	1.89	1060 ± 5%	2383	170 bar 2465 psi	+ 20 °C +68 °F	1494	3359	1717	3859	25,0	1,53	0,49	1,08	✓
RV 1200 - 013 - A	13	0.51	64	2.52	51	2.01					1553	3490	1802	4052	30,0	1,83	0,51	1,12	✓
RV 1200 - 016 - A	16	0.63	70	2.76	54	2.13					1597	3591	1869	4202	34,0	2,07	0,54	1,19	✓
RV 1200 - 019 - A	19	0.75	76	2.99	57	2.24					1633	3671	1922	4321	39,0	2,38	0,56	1,23	✓
RV 1200 - 025 - A	25	0.98	88	3.46	63	2.48					1685	3789	2001	4500	48,0	2,93	0,61	1,34	✓
RV 1200 - 032 - A	32	1.26	102	4.02	70	2.76					1728	3884	2066	4644	59,0	3,60	0,67	1,48	✓
RV 1200 - 038 - A	38	1.50	114	4.49	76	2.99					1754	3943	2106	4735	69,0	4,21	0,72	1,59	✓
RV 1200 - 050 - A	50	1.97	138	5.43	88	3.46					1791	4026	2163	4863	88,0	5,37	0,81	1,79	✓
RV 1200 - 063 - A	63	2.48	164	6.46	101	3.98					1817	4085	2204	4954	108,0	6,59	0,92	2,03	✓
RV 1200 - 075 - A	75	2.95	188	7.40	113	4.45					1834	4124	2230	5013	127,0	7,75	1,01	2,23	✓
RV 1200 - 080 - A	80	3.15	198	7.80	118	4.65					1840	4137	2239	5033	135,0	8,24	1,05	2,31	✓
RV 1200 - 100 - A	100	3.94	238	9.37	138	5.43					1858	4177	2267	5096	166,0	10,13	1,21	2,67	✓
RV 1200 - 125 - A	125	4.92	288	11.34	163	6.42					1873	4210	2290	5148	205,0	12,51	1,41	3,11	✓

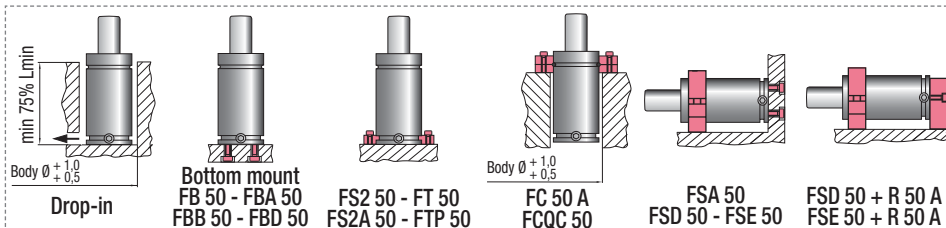

HOW TO ORDER

(10 pcs) RV 1200-050-A
(10 pcs) RV 1200-050-A-N

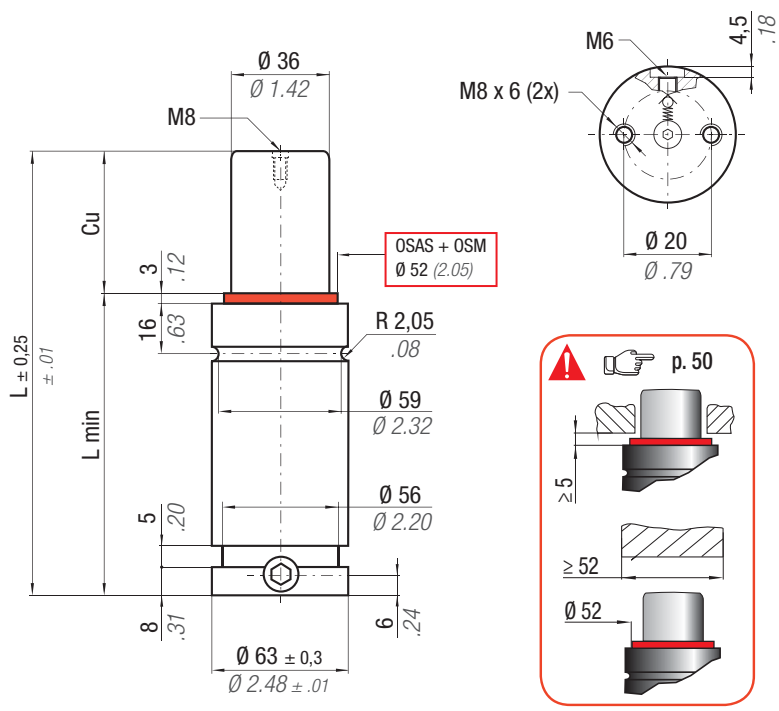

OSAS + OSM = OVER STROKE ACTIVE SAFETY + OVER STROKE MARKER

easyl MANIFOLD p. 211

* F_{1i} = Isothermal end force at 100% Cu p. 16
 ** F_{1p} = Polyphotic end force at 100% Cu



ACTIVE SAFETY



OSAS



USAS



OPAS

RV

	$^{\circ}\text{F}$ 32 - 176	$^{\circ}\text{C}$ 0 - 80	ΔP $\pm 0,33\% / ^{\circ}\text{C}$	P max 150 bar 2175 psi	P min 20 bar 290 psi	S 10,18 cm ² 1.578 in ²	SPM ~ 20 - 100 (at 20°C)	Max Speed 1,8 m/s	Maintenance kit 39BMRV01500C
--	--------------------------------	------------------------------	---	-------------------------------------	-----------------------------------	--	---------------------------------------	-----------------------------	--

CODE	Cu		L		L min		F ₀ Initial force		F _{1i} * End force		F _{1p} ** End force		V ₀		PED 2014/68/EU		
	mm	inch	mm	inch	mm	inch	daN	lb	daN	lb	daN	lb	cm ³	in ³	~Kg	~lb	
RV 1500 - 010 - A	10	0.39	64	2.52	54	2.13	1530 ± 5%	3440	2074	4663	2400	5395	45,0	2.75	0,88	1.94	✓
RV 1500 - 013 - A	13	0.51	70	2.76	57	2.24			2152	4838	2521	5667	53,0	3.23	0,91	2.01	✓
RV 1500 - 016 - A	16	0.63	76	2.99	60	2.36			2213	4975	2616	5881	61,0	3.72	0,96	2.12	✓
RV 1500 - 019 - A	19	0.75	82	3.23	63	2.48			2262	5085	2693	6054	69,0	4.21	0,99	2.18	✓
RV 1500 - 025 - A	25	0.98	94	3.70	69	2.72			2336	5252	2811	6319	85,0	5.19	1,06	2.34	✓
RV 1500 - 032 - A	32	1.26	108	4.25	76	2.99			2397	5389	2908	6537	103,0	6.28	1,14	2.51	✓
RV 1500 - 038 - A	38	1.50	120	4.72	82	3.23			2435	5475	2971	6679	119,0	7.26	1,21	2.67	✓
RV 1500 - 050 - A	50	1.97	144	5.67	94	3.70			2490	5597	3059	6877	151,0	9.21	1,36	3.00	✓
RV 1500 - 063 - A	63	2.48	170	6.69	107	4.21			2529	5685	3123	7021	186,0	11.35	1,52	3.35	✓
RV 1500 - 075 - A	75	2.95	194	7.64	119	4.69			2555	5743	3165	7115	217,0	13.24	1,66	3.66	✓
RV 1500 - 080 - A	80	3.15	204	8.03	124	4.88	2563	5763	3180	7149	231,0	14.09	1,72	3.79	✓		
RV 1500 - 100 - A	100	3.94	244	9.61	144	5.67	2590	5824	3224	7248	284,0	17.32	1,95	4.30	✓		
RV 1500 - 125 - A	125	4.92	294	11.57	169	6.65	2613	5875	3262	7333	350,0	21.36	2,24	4.94	✓		

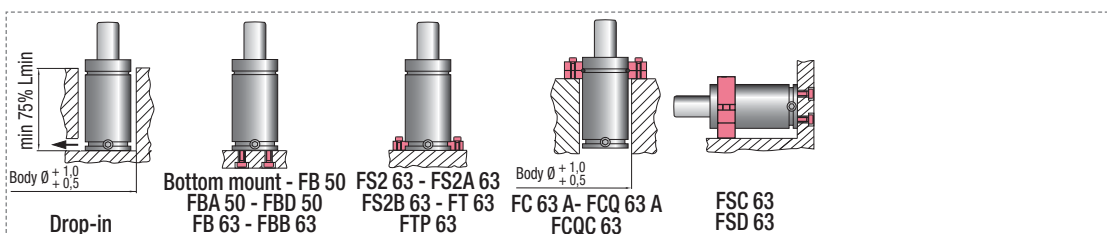

HOW TO ORDER

(10 pcs) RV 1500-050-A
 (10 pcs) RV 1500-050-A-N

RV 2400

ISO 11901 - 3 B8 3180 220 000 004(MB)	VDI 3003 - Blatt 3 E24.54.815.G (PSA)	B2 4005 (BMW) 39D 997 (VW)	W-DX35-6204 (Ford)
--	--	-------------------------------	--------------------



OSAS + OSM = OVER STROKE ACTIVE SAFETY + OVER STROKE MARKER

ACTIVE SAFETY

easyl MANIFOLD p. 211



OSAS

* F_{1i} = Isothermal end force at 100% Cu p. 16

** F_{1p} = Polytropic end force at 100% Cu



USAS



OPAS

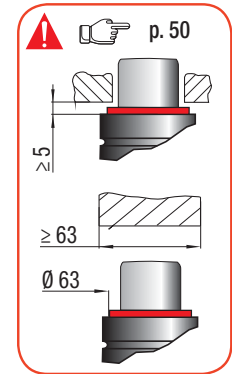
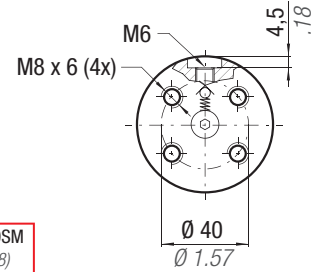
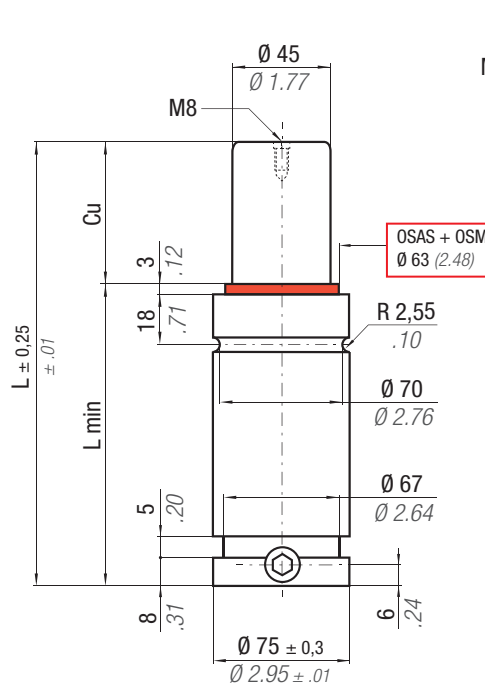

	°F 32 - 176	°C 0 - 80	ΔP ± 0,33 %/°C	P max 150 bar 2175 psi	P min 20 bar 290 psi	S 15,90 cm ² 2,465 in ²	SPM ~ 20 - 100 (at 20°C)	Max Speed 1,8 m/s	Maintenance kit 39BMRV02400C
--	----------------------	--------------------	---------------------------	-------------------------------------	-----------------------------------	--	---------------------------------------	-----------------------------	--

CODE	Cu		L		L min		F ₀		F _{1i} *		F _{1p} **		V ₀		PED		
	mm	inch	mm	inch	mm	inch	daN	lb	daN	lb	daN	lb	cm ³	in ³	~Kg	~lb	2014/68/EU
RV 2400 - 010 - A	10	0.39	65	2.56	55	2.17	2385 ± 5%	5362	3264	7338	3786	8511	69,0	4.21	1,25	2.76	✓
RV 2400 - 013 - A	13	0.51	71	2.80	58	2.28			3392	7626	3984	8956	81,0	4.94	1,30	2.87	✓
RV 2400 - 016 - A	16	0.63	77	3.03	61	2.40			3493	7852	4142	9312	93,0	5.67	1,35	2.98	✓
RV 2400 - 019 - A	19	0.75	83	3.27	64	2.52			3574	8035	4271	9602	105,0	6.41	1,40	3.09	✓
RV 2400 - 025 - A	25	0.98	95	3.74	70	2.76			3698	8313	4468	10044	129,0	7.87	1,50	3.31	✓
RV 2400 - 032 - A	32	1.26	109	4.29	77	3.03			3800	8542	4632	10413	157,0	9.58	1,61	3.55	✓
RV 2400 - 038 - A	38	1.50	121	4.76	83	3.27			3864	8687	4737	10649	181,0	11.04	1,70	3.75	✓
RV 2400 - 050 - A	50	1.97	145	5.71	95	3.74			3956	8893	4887	10986	230,0	14.03	1,89	4.17	✓
RV 2400 - 063 - A	63	2.48	171	6.73	108	4.25			4022	9042	4996	11231	282,0	17.20	2,10	4.63	✓
RV 2400 - 075 - A	75	2.95	195	7.68	120	4.72			4066	9140	5068	11393	330,0	20.13	2,29	5.05	✓
RV 2400 - 080 - A	80	3.15	205	8.07	125	4.92	4081	9174	5093	11450	350,0	21.35	2,37	5.22	✓		
RV 2400 - 100 - A	100	3.94	245	9.65	145	5.71	4127	9278	5169	11620	431,0	26.29	2,68	5.91	✓		
RV 2400 - 125 - A	125	4.92	295	11.61	170	6.69	4166	9365	5234	11767	532,0	32.45	3,07	6.77	✓		

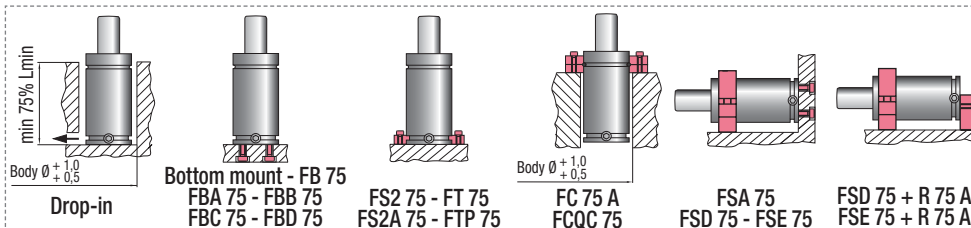

HOW TO ORDER

(10 pcs) RV 2400-050-A
(10 pcs) RV 2400-050-A-N

ISO 11901 - 3	VDI 3003 - Blatt 3	B2 4005 (BMW)	075.90.60 (FCA)
W-DX35-6204 (Ford)	PG 24D (Mazda)	B8 3180 220 000 004(MB)	E24.54.815.G (PSA)
39D 997 (VW)			

RV 4200

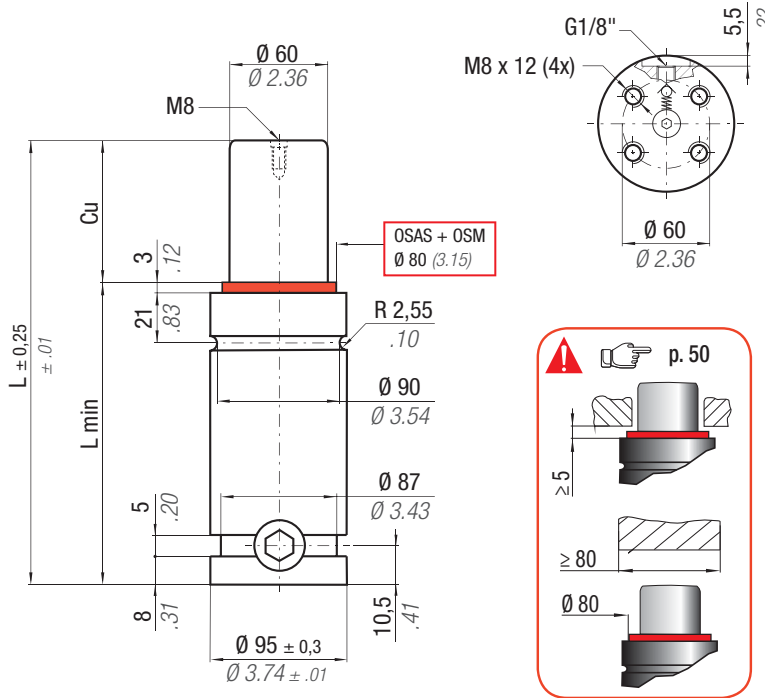

OSAS + OSM = OVER STROKE ACTIVE SAFETY + OVER STROKE MARKER



easyl MANIFOLD p. 211

ACTIVE SAFETY

* F_{1i} = Isothermal end force at 100% Cu p. 16
 ** F_{1p} = Polyphoric end force at 100% Cu

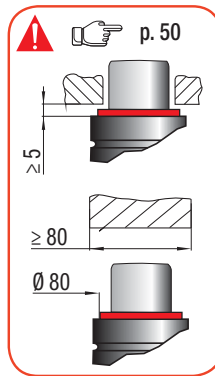

	°F 32 - 176 °C 0 - 80	ΔP ± 0,33 %/°C	P max 150 bar 2175 psi	P min 20 bar 290 psi	S 28,27 cm ² 4.382 in ²	SPM ~ 20 - 100 (at 20°C)	Max Speed 1,8 m/s	Maintenance kit 39BMRV04200C
--	--------------------------	---------------------------	-------------------------------------	-----------------------------------	--	---------------------------------------	-----------------------------	--

CODE	Cu		L		L min		F ₀ Initial force		F _{1i} * End force		F _{1p} ** End force		V ₀		Maintenance kit		PED 2014/68/EU
	mm	inch	mm	inch	mm	inch	daN	lb	daN	lb	daN	lb	cm ³	in ³	~Kg	~lb	
RV 4200 - 016 - A	16	0.63	90	3.54	74	2.91	4240 ± 5% 150 bar 2175 psi + 20 °C +68 °F	9532	6080	13669	7162	16101	173,0	10.55	2,76	6.08	✓
RV 4200 - 019 - A	19	0.75	96	3.78	77	3.03			6246	14041	7421	16683	193,0	11.77	2,84	6.26	✓
RV 4200 - 025 - A	25	0.98	108	4.25	83	3.27			6506	14626	7834	17612	234,0	14.27	2,99	6.59	✓
RV 4200 - 032 - A	32	1.26	122	4.80	90	3.54			6729	15128	8194	18421	281,0	17.14	3,16	6.97	✓
RV 4200 - 038 - A	38	1.50	134	5.28	96	3.78			6876	15458	8432	18956	322,0	19.64	3,31	7.30	✓
RV 4200 - 050 - A	50	1.97	158	6.22	108	4.25			7091	15940	8783	19745	403,0	24.58	3,61	7.96	✓
RV 4200 - 063 - A	63	2.48	184	7.24	121	4.76			7251	16301	9048	20341	491,0	29.95	3,94	8.69	✓
RV 4200 - 075 - A	75	2.95	208	8.19	133	5.24			7359	16543	9227	20743	572,0	34.89	4,24	9.35	✓
RV 4200 - 080 - A	80	3.15	218	8.58	138	5.43			7396	16626	9288	20880	606,0	36.97	4,36	9.61	✓
RV 4200 - 100 - A	100	3.94	258	10.16	158	6.22			7512	16888	9483	21319	741,0	45.20	4,86	10.71	✓
RV 4200 - 125 - A	125	4.92	308	12.13	183	7.20	7612	17113	9651	21696	910,0	55.51	5,48	12.08	✓		

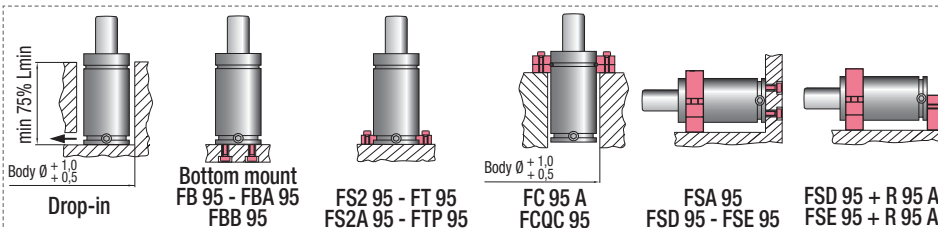

HOW TO ORDER

(10 pcs) RV 4200-050-A
 (10 pcs) RV 4200-050-A-N

RV 6600

ISO 11901 - 3	VDI 3003 - Blatt 3	B2 4005 (BMW)	075.90.60 (FCA)
W-DX35-6204 (Ford)	B8 3180 220 000 004(MB)	39D 997 (VW)	



OSAS + OSM = OVER STROKE ACTIVE SAFETY + OVER STROKE MARKER

ACTIVE SAFETY

easyl MANIFOLD p. 211



OSAS

* F_{1i} = Isothermal end force at 100% Cu p. 16

** F_{1p} = Polytrophic end force at 100% Cu



USAS



OPAS

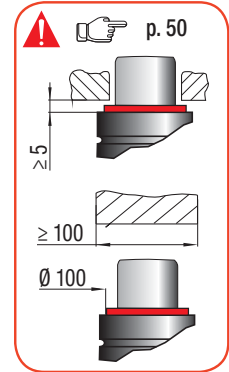
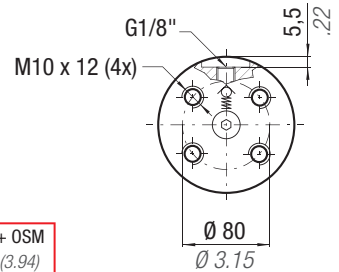
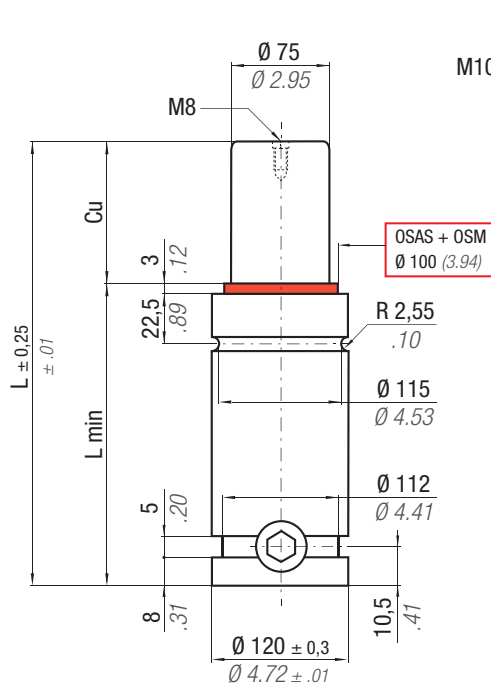

N ₂	°F 32 - 176	°C 0 - 80	ΔP ± 0,33 %/°C	P max 150 bar 2175 psi	P min 20 bar 290 psi	S 44,18 cm ² 6.848 in ²	SPM ~ 20 - 100 (at 20°C)	Max Speed 1,8 m/s	Maintenance kit 39BMRV06600C
----------------	----------------------	--------------------	---------------------------	------------------------------	----------------------------	---	--------------------------------	----------------------	---------------------------------

CODE	Cu		L		L min		F ₀		F _{1i} *		F _{1p} **		V ₀		PED		
	mm	inch	mm	inch	mm	inch	daN	lb	daN	lb	daN	lb	cm ³	in ³	~Kg	~lb	2014/68/EU
RV 6600 - 016 - A	16	0.63	100	3.94	84	3.31	6630 ± 5%	14904	9125	20515	10607	23845	300,0	18.30	5,12	11.29	✓
RV 6600 - 019 - A	19	0.75	106	4.17	87	3.43			9376	21077	10995	24718	332,0	20.25	5,23	11.53	✓
RV 6600 - 025 - A	25	0.98	118	4.65	93	3.66			9779	21985	11628	26141	396,0	24.16	5,47	12.06	✓
RV 6600 - 032 - A	32	1.26	132	5.20	100	3.94			10136	22787	12195	27415	471,0	28.73	5,75	12.68	✓
RV 6600 - 038 - A	38	1.50	144	5.67	106	4.17			10375	23325	12578	28276	535,0	32.64	5,99	13.21	✓
RV 6600 - 050 - A	50	1.97	168	6.61	118	4.65			10733	24129	13157	29578	663,0	40.44	6,47	14.26	✓
RV 6600 - 063 - A	63	2.48	194	7.64	131	5.16			11006	24743	13604	30583	801,0	48.86	6,99	15.41	✓
RV 6600 - 075 - A	75	2.95	218	8.58	143	5.63			11193	25163	13911	31273	930,0	56.73	7,47	16.47	✓
RV 6600 - 080 - A	80	3.15	228	8.98	148	5.83			11258	25308	14018	31514	983,0	59.96	7,67	16.91	✓
RV 6600 - 100 - A	100	3.94	268	10.55	168	6.61			11463	25771	14359	32280	1197,0	73.02	8,46	18.65	✓
RV 6600 - 125 - A	125	4.92	318	12.52	193	7.60	11642	26171	14656	32948	1464,0	89.30	9,46	20.86	✓		

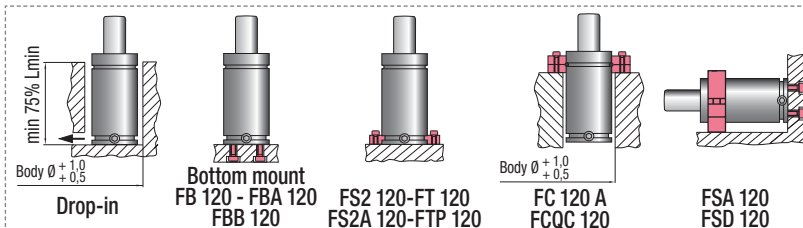

HOW TO ORDER

(10 pcs) RV 6600-050-A
(10 pcs) RV 6600-050-A-N

ISO 11901 - 3 W-DX35-6204 (Ford)	VDI 3003 - Blatt 3 PG 24D (Mazda)	B2 4005 (BMW) B8 3180 220 000 004(MB)	075.90.60 (FCA) 39D 997 (VW)
-------------------------------------	--------------------------------------	--	---------------------------------

RV 9500

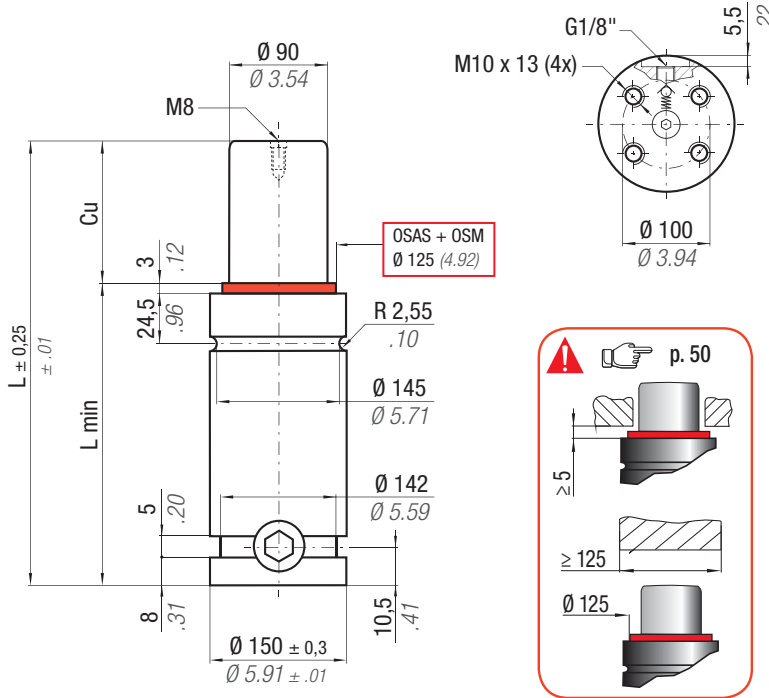

OSAS + OSM = OVER STROKE ACTIVE SAFETY + OVER STROKE MARKER



easu MANIFOLD p. 211

ACTIVE SAFETY

* F_{1i} =

Isothermal end force at 100% Cu

p. 16

** F_{1p} =

Polytropic end force at 100% Cu



OSAS



USAS



OPAS

RV

	$^{\circ}\text{F}$ 32 176	$^{\circ}\text{C}$ 0 80	ΔP $\pm 0,33\% / ^{\circ}\text{C}$	P max 150 bar 2175 psi	P min 20 bar 290 psi	S 63,62 cm ² 9.864 in ²	SPM ~ 20 - 100 (at 20°C)	Max Speed 1,8 m/s	Maintenance kit 39BMRV09500C
--	---------------------------------	-------------------------------	---	-------------------------------------	-----------------------------------	--	---------------------------------------	-----------------------------	--

CODE	Cu		L		L min		F ₀ Initial force		F _{1i} * End force		F _{1p} ** End force		V ₀		PED 2014/68/EU		
	mm	inch	mm	inch	mm	inch	daN	lb	daN	lb	daN	lb	cm ³	in ³	~Kg	~lb	
RV 9500 - 019 - A	19	0.75	116	4.57	97	3.82			13101	29453	15214	34202	517,0	31.54	9,56	21.08	✓
RV 9500 - 025 - A	25	0.98	128	5.04	103	4.06			13637	30656	16044	36068	614,0	37.45	9,93	21.89	✓
RV 9500 - 032 - A	32	1.26	142	5.59	110	4.33	9540	21446	14112	31726	16792	37750	727,0	44.35	10,37	22.86	✓
RV 9500 - 038 - A	38	1.50	154	6.06	116	4.57	± 5%		14432	32445	17299	38890	823,0	50.20	10,74	23.68	✓
RV 9500 - 050 - A	50	1.97	178	7.01	128	5.04			14914	33528	18070	40623	1017,0	62.04	11,49	25.33	✓
RV 9500 - 063 - A	63	2.48	204	8.03	141	5.55	150 bar	2175 psi	15283	34358	18666	41963	1226,0	74.79	12,30	27.12	✓
RV 9500 - 075 - A	75	2.95	228	8.98	153	6.02			15536	34927	19078	42889	1420,0	86.62	13,05	28.77	✓
RV 9500 - 080 - A	80	3.15	238	9.37	158	6.22	+ 20 °C	+ 68 °F	15625	35125	19222	43213	1500,0	91.50	13,37	29.48	✓
RV 9500 - 100 - A	100	3.94	278	10.94	178	7.01			15905	35756	19681	44245	1823,0	111.20	14,61	32.21	✓
RV 9500 - 125 - A	125	4.92	328	12.91	203	7.99			16148	36303	20082	45146	2226,0	135.79	16,18	35.67	✓

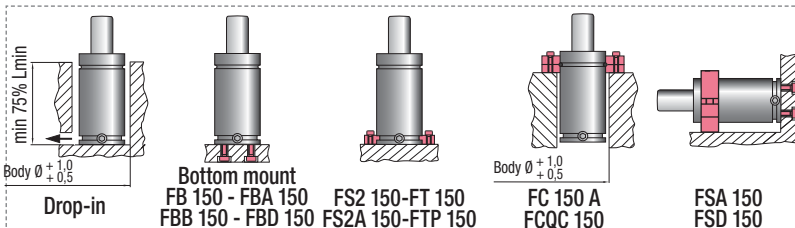

HOW TO ORDER

(10 pcs) RV 9500-050-A
(10 pcs) RV 9500-050-A-N



OSAS + OSM = OVER STROKE ACTIVE SAFETY + OVER STROKE MARKER

ACTIVE SAFETY

easyl MANIFOLD p. 211



OSAS

* F_{1i} = Isothermal end force at 100% Cu p. 16

** F_{1p} = Polytrophic end force at 100% Cu



USAS



OPAS

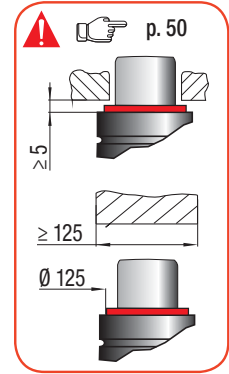
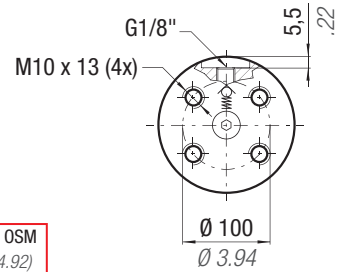
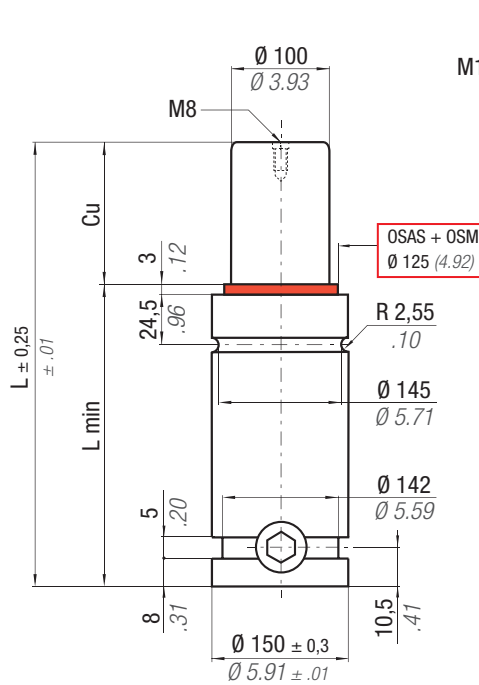

CODE	N ₂	°F 32 - 176	°C 0 - 80	ΔP ± 0,33 %/°C	P max 150 bar 2175 psi	P min 20 bar 290 psi	S 78,54 cm ² 12.173 in ²	SPM ~ 20 - 80 (at 20°C)	Max Speed 1,8 m/s	Maintenance kit 39BMRV12000A	PED 2014/68/EU
RV 12000 - 019 - A											
RV 12000 - 025 - A											
RV 12000 - 032 - A											
RV 12000 - 038 - A											
RV 12000 - 050 - A											
RV 12000 - 063 - A											
RV 12000 - 075 - A											
RV 12000 - 080 - A											
RV 12000 - 100 - A											
RV 12000 - 125 - A											

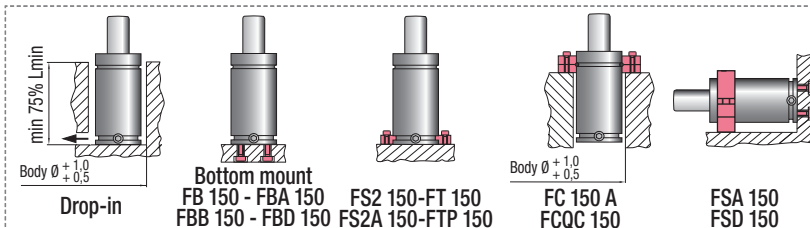

HOW TO ORDER

(10 pcs) RV 12000-050-A
(10 pcs) RV 12000-050-A-N

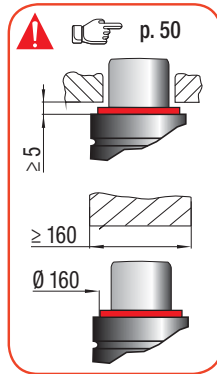
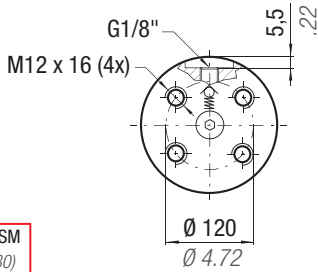
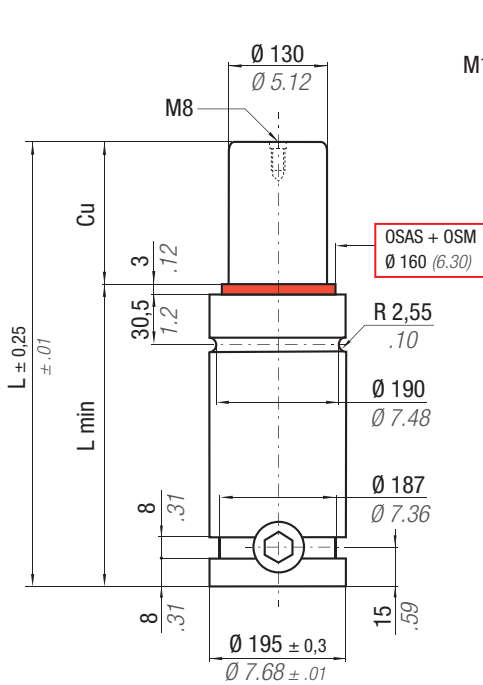

OSAS + OSM = OVER STROKE ACTIVE SAFETY + OVER STROKE MARKER



easu MANIFOLD p. 211

* F_{1i} = Isothermal end force at 100% Cu p. 16
 ** F_{1p} = Polytrophic end force at 100% Cu

ACTIVE SAFETY



OSAS



USAS



OPAS

RV

	°F 32 - 176	°C 0 - 80	ΔP ± 0,33 %/°C	P max 150 bar 2175 psi	P min 20 bar 290 psi	S 132,73 cm ² 20.573 in ²	SPM ~ 20 - 100 (at 20°C)	Max Speed 1,8 m/s	Maintenance kit 39BMRV20000A
--	----------------------	--------------------	---------------------------	-------------------------------------	-----------------------------------	--	---------------------------------------	-----------------------------	--

CODE	Cu		L		L min		F ₀ Initial force		F _{1i} * End force		F _{1p} ** End force		V ₀		PED 2014/68/EU		
	mm	inch	mm	inch	mm	inch	daN	lb	daN	lb	daN	lb	cm ³	in ³	~Kg	~lb	
RV 20000 - 019 - A	19	0.75	148	5.83	129	5.08	19910 ± 5% 44738 150 bar 2175 psi + 20 °C +68 °F		26987	60669	31207	70156	1118,0	68.20	21,58	47.58	✓
RV 20000 - 025 - A	25	0.98	160	6.30	135	5.32			28383	63807	33368	75014	1288,0	78.57	22,29	49.14	✓
RV 20000 - 032 - A	32	1.26	174	6.85	142	5.59			29722	66817	35474	79749	1486,0	90.65	23,12	50.97	✓
RV 20000 - 038 - A	38	1.50	186	7.32	148	5.83			30681	68973	37002	83184	1656,0	101.02	23,84	52.56	✓
RV 20000 - 050 - A	50	1.97	210	8.27	160	6.30			32220	72433	39486	88768	1995,0	121.70	25,26	55.69	✓
RV 20000 - 063 - A	63	2.48	236	9.29	173	6.81			33486	75280	41560	93431	2362,0	144.08	26,80	59.08	✓
RV 20000 - 075 - A	75	2.95	260	10.24	185	7.28			34403	77341	43077	96841	2702,0	164.82	28,22	62.21	✓
RV 20000 - 080 - A	80	3.15	270	10.63	190	7.48			34731	78079	43624	98071	2843,0	173.42	28,81	63.52	✓
RV 20000 - 100 - A	100	3.94	310	12.21	210	8.27			35811	80506	45434	102140	3409,0	207.95	31,19	68.76	✓
RV 20000 - 125 - A	125	4.92	360	14.17	235	9.25			36794	82716	47097	105878	4116,0	251.08	34,16	75.31	✓

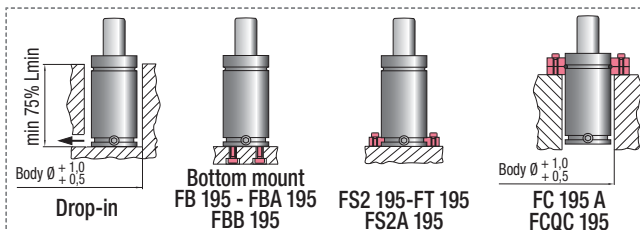

HOW TO ORDER

(10 pcs) RV 20000-050-A
 (10 pcs) RV 20000-050-A-N

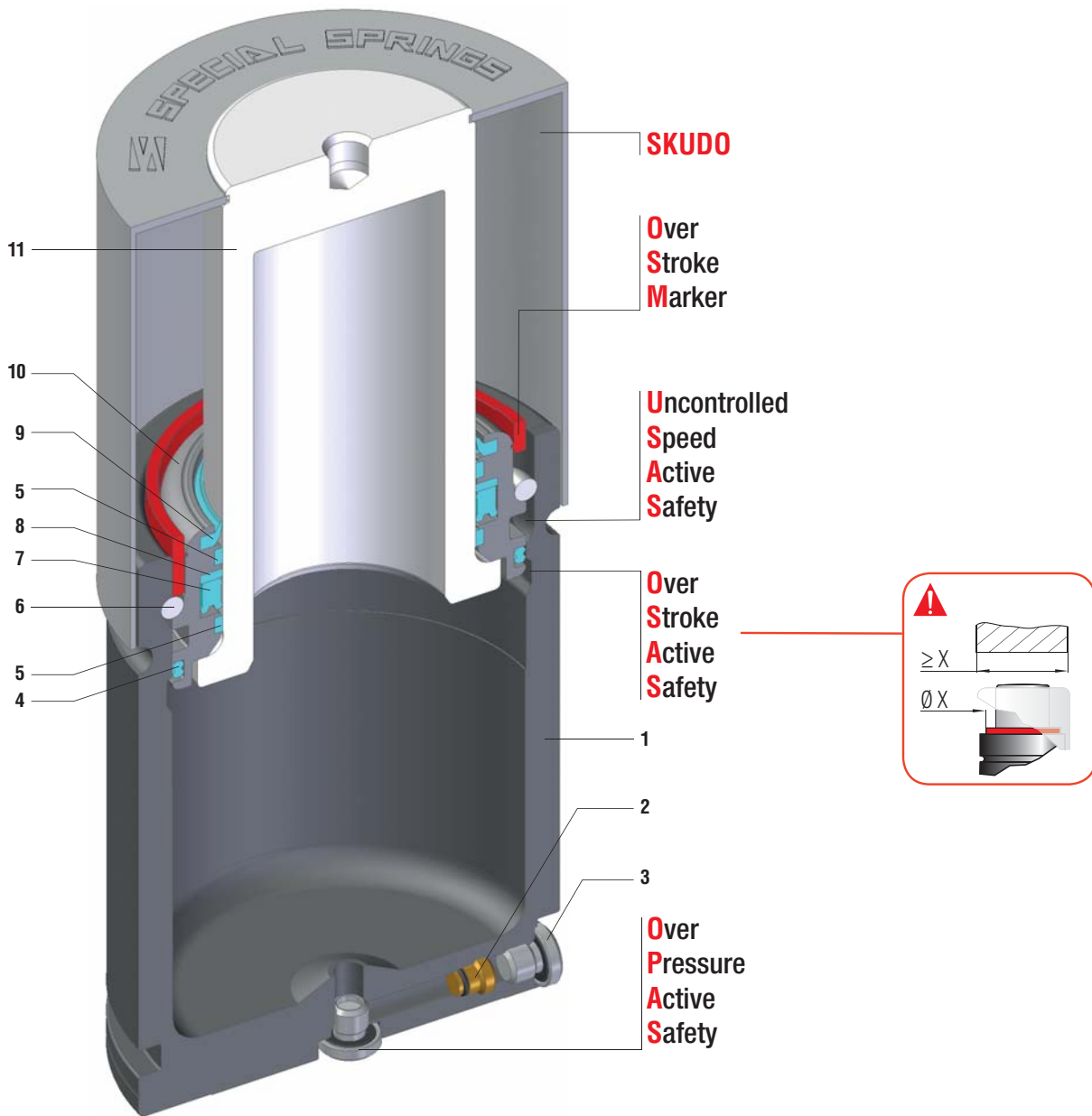

Minima altezza, massima forza + SKUDO - Minimum height, maximum force + SKUDO - Minimale Höhe, maximale Kraft + SKUDO
 Hauteur minimale, force maximale + SKUDO - Mínima altura, máxima fuerza + SKUDO - Altura mínima, força máxima + SKUDO

SEALING	ROD SEAL
DESIGN	BUSH - BODY DESIGN

1	Body	5	Guide ring	9	Rod wiper
2	Valve	6	Retaining ring	10	Bush
3	Plug	7	Rod seal	11	Rod (nitrited superfinished)
4	Dual ring seal	8	Back-up ring		

RANGE CHART

Model	Body Ø		Stroke Cu		Initial force F0					
	mm	inch	mm	inch	daN	lb				
RS 170	19	0.75	7 - 122	0.28 - 4.80	170	382	-	-	✓	✓
RS 320	25	0.98	7 - 122	0.28 - 4.80	320	719	-	-	✓	✓
RS 350	32	1.26	7 - 122	0.28 - 4.80	360	809	✓	✓	✓	✓
RS 500	38	1.50	7 - 122	0.28 - 4.80	470	1057	✓	✓	✓	✓
RS 750	45	1.77	7 - 122	0.28 - 4.80	740	1664	✓	✓	✓	✓
RS 1000	50	1.97	10 - 122	0.39 - 4.80	920	2068	✓	✓	✓	✓
RS 1200	50	1.97	10 - 122	0.39 - 4.80	1060	2383	✓	✓	✓	✓
RS 1500	63	2.48	10 - 122	0.39 - 4.80	1530	3440	✓	✓	✓	✓
RS 2400	75	2.95	13 - 122	0.51 - 4.80	2385	5362	✓	✓	✓	✓
RS 4200	95	3.74	13 - 122	0.51 - 4.80	4240	9532	✓	✓	✓	✓
RS 6600	120	4.72	13 - 122	0.51 - 4.80	6630	14905	✓	✓	✓	✓
RS 9500	150	5.91	16 - 122	0.63 - 4.80	9540	21447	✓	✓	✓	✓

RS



HOW TO ORDER



RS 2400-050-A - N - E

- IT** Codice cilindro autonomo
- EN** Self-contained cylinder code
- DE** Kode des eingeständigen Gdf.
- FR** Code du cylindre autonome
- ES** Código del cilindro autónomo
- PT** Código do cilindro autónomo

- IT** Collegabile con tubi, cilindro fornito scarico e senza valvola unidirezionale
- EN** Linkable with hoses, cylinder supplied without pressure and oneway valve
- DE** Anschlussfähig mit Leitungen, Gdf. geliefert ohne Druck und RückschlagVentil
- FR** Connectable avec tubes, ressort fourni sans pression ni valve unidirectionelle
- ES** Connectable con tubos, cilindro suministrado sin presión y sin válvula unidireccional
- PT** Acompláveis com tubos, cilindro fornecidos sem pressão e sem válvula unidireccional

- IT** Collegabile EASY MANIFOLD, fornito scarico + guarnizione di collegamento
- EN** Linkable EASY MANIFOLD, supplied without pressure + connecting seal
- DE** Anschlussfähig EASY MANIFOLD, geliefert ohne Druck + Verbindungsdichtung
- FR** Connectable EASY MANIFOLD, fourni sans pression + joint de connexion
- ES** Connectable EASY MANIFOLD, suministrado sin presión + junta de conexión
- PT** Acompláveis EASY MANIFOLD, fornecidos sem pressão + vedantes de conexão

ACTIVE SAFETY

Il nuovo codice sarà fornito solo ad esaurimento del vecchio

The new code will be supplied only when the old will be out of stock

Der neue Kode wird geliefert nur wenn der alte nicht mehr im Lager ist

Le nouveau code sera fourni uniquement lorsque le vieux stock sera écoulé

El nuevo código será suministrado sólo cuando el viejo está fuera de stock

O novo código irá ser fornecido apenas quando o antigo esgotar stock

* $F_{1i} =$ Isothermal end force at 100% Cu ** $F_{1p} =$ Polytrophic end force at 100% Cu



OPAS



SKUDO



NOT FOR

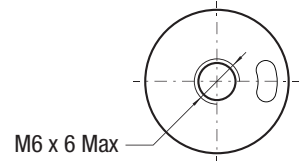
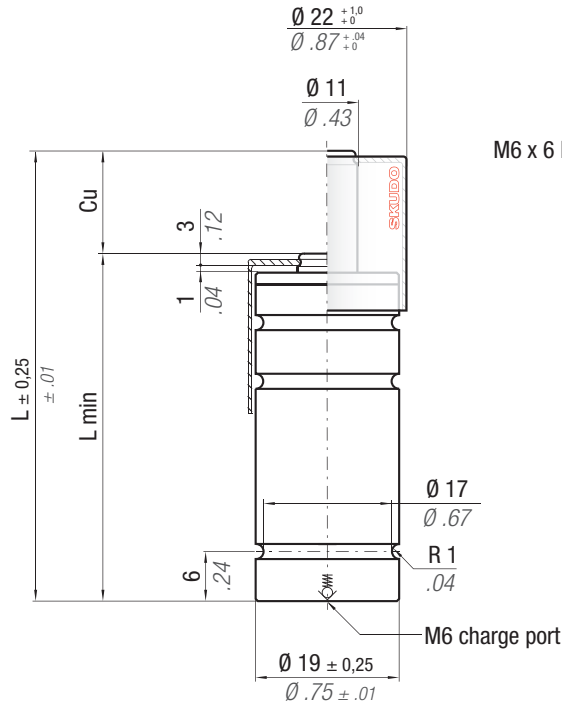
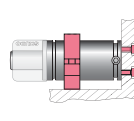
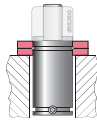

N ₂	°F 32 - 176 °C 0 - 80	ΔP ± 0,33 %/°C	P max 180 bar 2610 psi	P min 20 bar 290 psi	S 0,95 cm ² 0.147 in ²	SPM ~ 40 - 100 (at 20°C)	Max Speed 1,8 m/s	Maintenance kit Disposable
----------------	--------------------------	---------------------------	------------------------------	----------------------------	--	--------------------------------	----------------------	-------------------------------

CODE PHASING OUT from 09/2013	NEW	Cu		L		L min		F ₀ Initial force		F _{1i} * End force *		F _{1p} ** End force **		V ₀		PED 2014/68/EU		
		mm	inch	mm	inch	mm	inch	daN	lb	daN	lb	daN	lb	cm ³	in ³		~Kg	~lb
RS 170 - 007 - A	RS 170 - 007 - B	7	0.28	50	1.97	43	1.69	170 ± 5% 180 bar 2610 psi + 20 °C +68 °F	382	231	520	259	582	3,0	0.18	0,06	0.13	✓
RS 170 - 010 - A	RS 170 - 010 - B	10	0.39	56	2.20	46	1.81			245	551	279	627	4,0	0.24	0,07	0.14	✓
RS 170 - 012 - A	RS 170 - 012 - B	12	0.47	60	2.36	48	1.89			252	567	289	650	4,0	0.24	0,07	0.15	✓
RS 170 - 016 - A	RS 170 - 016 - B	16	0.63	68	2.68	52	2.05			263	592	305	686	5,0	0.31	0,07	0.16	✓
RS 170 - 022 - A	RS 170 - 022 - B	22	0.87	80	3.15	58	2.28			275	618	322	724	7,0	0.43	0,08	0.17	✓
RS 170 - 029 - A	RS 170 - 029 - B	29	1.14	94	3.70	65	2.56			284	639	336	755	8,0	0.49	0,09	0.19	✓
RS 170 - 035 - A	RS 170 - 035 - B	35	1.38	106	4.17	71	2.80			290	652	344	773	10,0	0.61	0,09	0.21	✓
RS 170 - 047 - A	RS 170 - 047 - B	47	1.85	130	5.12	83	3.27			298	669	356	800	13,0	0.79	0,11	0.24	✓
RS 170 - 060 - A	RS 170 - 060 - B	60	2.36	156	6.14	96	3.78			303	682	364	818	16,0	0.98	0,12	0.27	✓
RS 170 - 072 - A	RS 170 - 072 - B	72	2.83	185	7.28	113	4.45			296	665	353	794	19,0	1.16	0,14	0.31	✓
RS 170 - 077 - A	RS 170 - 077 - B	77	3.03	195	7.68	118	4.65			297	669	355	798	21,0	1.28	0,15	0.32	✓
RS 170 - 097 - A	RS 170 - 097 - B	97	3.82	235	9.25	138	5.43			303	680	363	816	25,0	1.53	0,17	0.37	✓
RS 170 - 122 - A	RS 170 - 122 - B	122	4.80	285	11.22	163	6.42			307	691	370	832	31,0	1.89	0,19	0.43	✓

WARNING REMOVE SKUDO

Upside down mounting

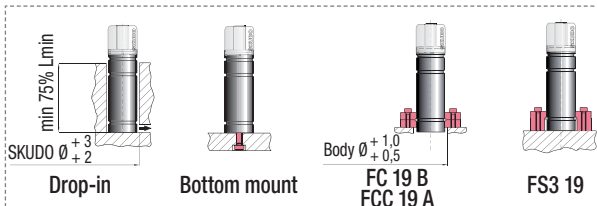

HOW TO ORDER
(10 pcs) RS 170-047-B

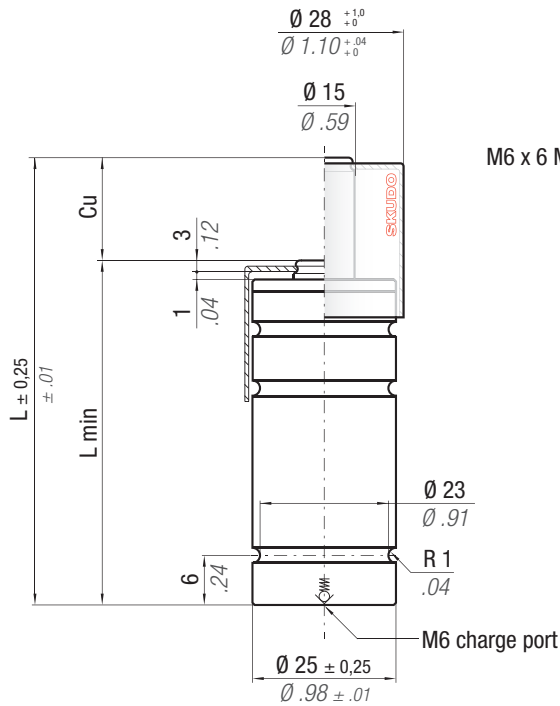

Il nuovo codice sarà fornito solo ad esaurimento del vecchio

The new code will be supplied only when the old will be out of stock

Der neue Kode wird geliefert nur wenn der alte nicht mehr im Lager ist

Le nouveau code sera fourni uniquement lorsque le vieux stock sera écoulé

El nuevo código será suministrado sólo cuando el viejo está fuera de stock

O novo código irá ser fornecido apenas quando o antigo esgotar stock

ACTIVE SAFETY

* $F_{1i} =$

Isothermal end force at 100% Cu



p. 16



** $F_{1p} =$

Polytropic end force at 100% Cu

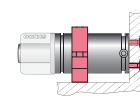
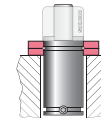

RS

	$^{\circ}\text{F}$ 32 - 176	$^{\circ}\text{C}$ 0 - 80	ΔP ± 0,33 %/°C	P max 180 bar 2610 psi	P min 20 bar 290 psi	S 1,77 cm ² 0.27 in ²	SPM ~ 40 - 100 (at 20°C)	Max Speed 1,8 m/s	Maintenance kit Disposable
--	--------------------------------------	------------------------------------	---------------------------------	-------------------------------------	-----------------------------------	--	---------------------------------------	-----------------------------	--------------------------------------

CODE PHASING OUT from 09/2013	NEW	Cu		L		L min		F0 Initial force		F _{1i} * End force *		F _{1p} ** End force **		V0		PED 2014/68/EU		
		mm	inch	mm	inch	mm	inch	daN	lb	daN	lb	daN	lb	cm ³	in ³	~Kg	~lb	✓
RS 320 - 007 - A	RS 320 - 007 - B	7	0.28	50	1.97	43	1.69	320 719 ± 5%	180 bar 2610psi	423	950	472	1061	6,0	0.37	0,10	0.23	✓
RS 320 - 010 - A	RS 320 - 010 - B	10	0.39	56	2.20	46	1.81			447	1004	506	1138	8,0	0.49	0,11	0.24	✓
RS 320 - 012 - A	RS 320 - 012 - B	12	0.47	60	2.36	48	1.89			459	1032	523	1176	8,0	0.49	0,11	0.25	✓
RS 320 - 016 - A	RS 320 - 016 - B	16	0.63	68	2.68	52	2.05			479	1077	552	1241	10,0	0.61	0,12	0.26	✓
RS 320 - 022 - A	RS 320 - 022 - B	22	0.87	80	3.15	58	2.28			499	1123	581	1306	13,0	0.79	0,13	0.29	✓
RS 320 - 029 - A	RS 320 - 029 - B	29	1.14	94	3.70	65	2.56			516	1159	605	1360	16,0	0.98	0,14	0.31	✓
RS 320 - 035 - A	RS 320 - 035 - B	35	1.38	106	4.17	71	2.80			526	1182	620	1394	19,0	1.16	0,15	0.33	✓
RS 320 - 047 - A	RS 320 - 047 - B	47	1.85	130	5.12	83	3.27			540	1213	641	1441	24,0	1.46	0,17	0.38	✓
RS 320 - 060 - A	RS 320 - 060 - B	60	2.36	156	6.14	96	3.78			549	1235	655	1472	30,0	1.83	0,19	0.43	✓
RS 320 - 072 - A	RS 320 - 072 - B	72	2.83	185	7.28	113	4.45			537	1207	636	1430	38,0	2.32	0,22	0.48	✓
RS 320 - 077 - A	RS 320 - 077 - B	77	3.03	195	7.68	118	4.65	540	1213	641	1441	40,0	2.44	0,23	0.50	✓		
RS 320 - 097 - A	RS 320 - 097 - B	97	3.82	235	9.25	138	5.43	549	1234	654	1470	49,0	2.99	0,26	0.57	✓		
RS 320 - 122 - A	RS 320 - 122 - B	122	4.80	285	11.22	163	6.42	557	1252	666	1497	60,0	4.09	0,30	0.66	✓		

WARNING REMOVE SKUDO

Upside down mounting

HOW TO ORDER

(10 pcs) RS 320-047-B

OSAS + OSM = OVER STROKE ACTIVE SAFETY + OVER STROKE MARKER

ACTIVE SAFETY



p. 211



OSAS



USAS



OPAS



SKUDO

* $F_{1i} =$

Isothermal end force at 100% Cu

p. 16

** $F_{1p} =$

Polytropic end force at 100% Cu

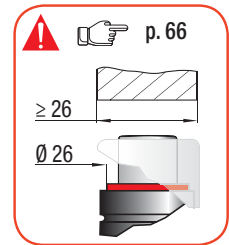
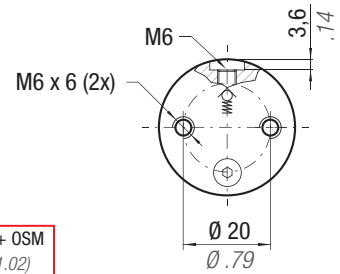
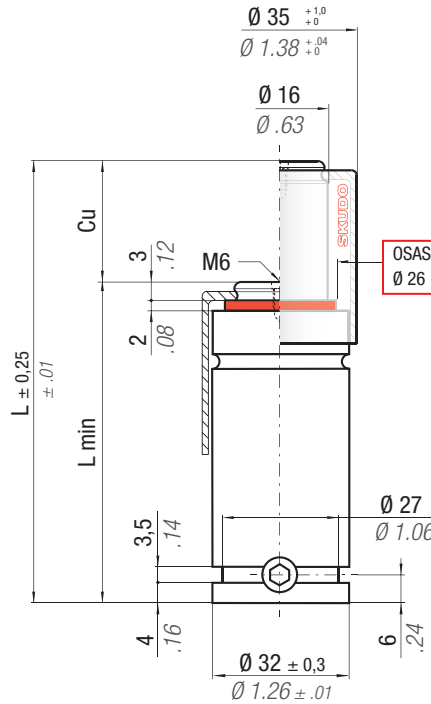
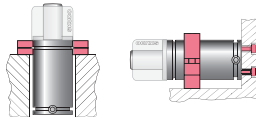

	°F 32 - 176	°C 0 - 80	ΔP ± 0,33 %/°C	P max 180 bar 2610 psi	P min 20 bar 290 psi	S 2,01 cm ² 0,312 in ²	SPM ~ 20 - 100 (at 20°C)	Max Speed 1,8 m/s	Maintenance kit 39BMRV00350C
--	----------------------	--------------------	---------------------------	------------------------------	----------------------------	--	--------------------------------	----------------------	---------------------------------

CODE	Cu		L		L min		F ₀		F _{1i} *		F _{1p} **		V ₀		PED		
	mm	inch	mm	inch	mm	inch	daN	lb	daN	lb	daN	lb	cm ³	in ³	~Kg	~lb	
RS 350 - 007 - A	7	0.28	50	1.97	43	1.69	360 ± 5% 180 bar 2610 psi + 20 °C +68 °F	809	458	1030	505	1136	8,0	0.49	0,16	0.36	✓
RS 350 - 010 - A	10	0.39	56	2.20	46	1.81			478	1075	533	1199	10,0	0.61	0,17	0.38	✓
RS 350 - 013 - A	13	0.51	62	2.44	49	1.93			493	1109	554	1245	12,0	0.73	0,18	0.40	✓
RS 350 - 016 - A	16	0.63	68	2.68	52	2.05			505	1134	570	1282	14,0	0.85	0,19	0.42	✓
RS 350 - 022 - A	22	0.87	80	3.15	58	2.28			521	1171	593	1333	18,0	1.10	0,21	0.46	✓
RS 350 - 029 - A	29	1.14	94	3.70	65	2.56			533	1199	611	1374	22,0	1.34	0,23	0.51	✓
RS 350 - 035 - A	35	1.38	106	4.17	71	2.80			541	1216	622	1399	26,0	1.59	0,25	0.55	✓
RS 350 - 047 - A	47	1.85	130	5.12	83	3.27			552	1240	637	1432	33,0	2.01	0,29	0.63	✓
RS 350 - 060 - A	60	2.36	156	6.14	96	3.78			559	1256	648	1456	41,0	2.50	0,33	0.72	✓
RS 350 - 072 - A	72	2.83	180	7.09	108	4.25			563	1266	654	1471	49,0	2.99	0,36	0.80	✓
RS 350 - 077 - A	77	3.03	190	7.48	113	4.45			565	1270	657	1476	52,0	3.17	0,38	0.83	✓
RS 350 - 097 - A	97	3.82	230	9.06	133	5.24			570	1281	663	1492	65,0	3.97	0,44	0.96	✓
RS 350 - 122 - A	122	4.80	280	11.02	158	6.22			574	1289	669	1504	80,0	4.88	0,51	1.13	✓

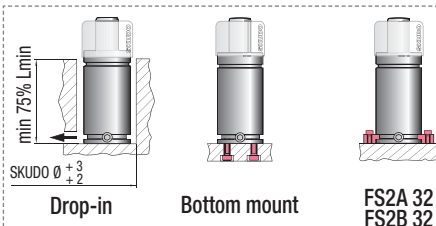
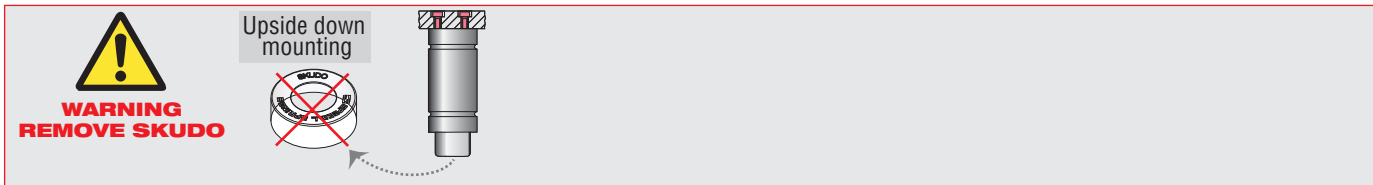

HOW TO ORDER

(10 pcs) RS 350-047-A
(10 pcs) RS 350-047-A-N

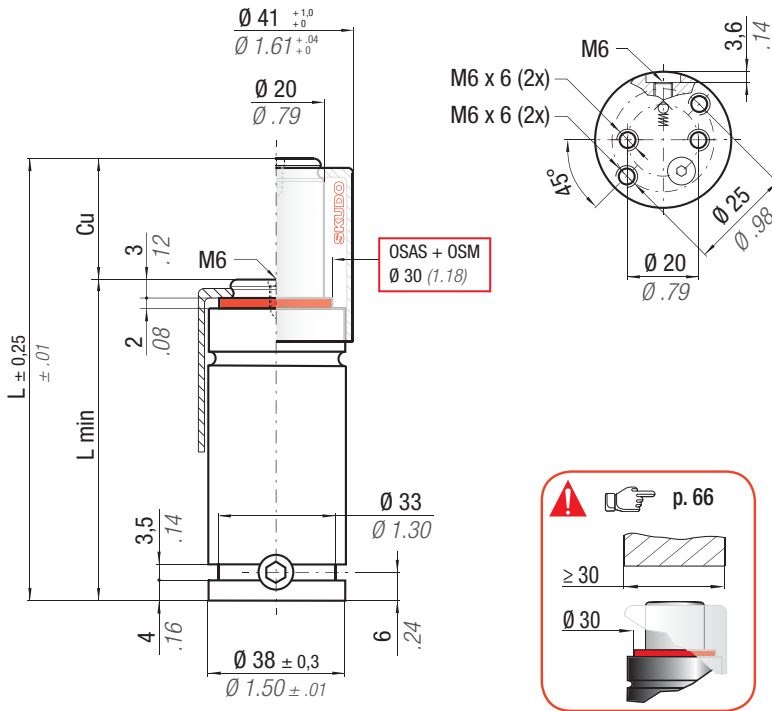

OSAS + OSM = OVER STROKE ACTIVE SAFETY + OVER STROKE MARKER

easli MANIFOLD p. 211

* F_{1i} = Isothermal end force at 100% Cu p. 16
 ** F_{1p} = Polytropic end force at 100% Cu

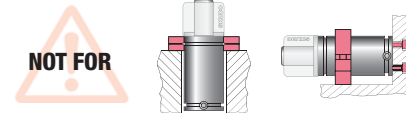

ACTIVE SAFETY



RS

	$^{\circ}F$ 32 - 176	$^{\circ}C$ 0 - 80	ΔP $\pm 0,33 \%/^{\circ}C$	P max 150 bar 2175 psi	P min 20 bar 290 psi	S 3,14 cm ² 0.487 in ²	SPM ~ 20 - 100 (at 20°C)	Max Speed 1,8 m/s	Maintenance kit 39BMRV00500C
--	-------------------------------	-----------------------------	---------------------------------------	-------------------------------------	-----------------------------------	---	---------------------------------------	-----------------------------	--

CODE	Cu		L		L min		F ₀ Initial force		F _{1i} * End force *		F _{1p} ** End force **		V ₀		PED 2014/68/EU		
	mm	inch	mm	inch	mm	inch	daN	lb	daN	lb	daN	lb	cm ³	in ³	~Kg	~lb	✓
RS 500 - 007 - A	7	0.28	50	1.97	43	1.69	470 1057 ± 5% 150 bar 2175psi + 20 °C +68 °F		609	1370	694	1560	11,0	0.67	0,24	0.53	✓
RS 500 - 010 - A	10	0.39	56	2.20	46	1.81			639	1437	739	1661	14,0	0.85	0,25	0.55	✓
RS 500 - 013 - A	13	0.51	62	2.44	49	1.93			661	1486	773	1738	17,0	1.04	0,26	0.57	✓
RS 500 - 016 - A	16	0.63	68	2.68	52	2.05			678	1524	800	1798	19,0	1.16	0,28	0.62	✓
RS 500 - 022 - A	22	0.87	80	3.15	58	2.28			703	1579	838	1884	24,0	1.46	0,31	0.68	✓
RS 500 - 029 - A	29	1.14	94	3.70	65	2.56			722	1622	868	1951	30,0	1.83	0,34	0.75	✓
RS 500 - 035 - A	35	1.38	106	4.17	71	2.80			733	1648	887	1994	35,0	2.14	0,37	0.82	✓
RS 500 - 047 - A	47	1.85	130	5.12	83	3.27			749	1684	913	2053	46,0	2.81	0,42	0.93	✓
RS 500 - 060 - A	60	2.36	156	6.14	96	3.78			760	1709	931	2093	57,0	3.48	0,48	1.06	✓
RS 500 - 072 - A	72	2.83	180	7.09	108	4.25			767	1725	942	2118	67,0	4.09	0,54	1.19	✓
RS 500 - 077 - A	77	3.03	190	7.48	113	4.45			770	1730	946	2127	72,0	4.39	0,56	1.23	✓
RS 500 - 097 - A	97	3.82	230	9.06	133	5.24			777	1747	958	2154	89,0	5.43	0,66	1.46	✓
RS 500 - 122 - A	122	4.80	280	11.02	158	6.22			783	1760	968	2176	110,0	6.71	0,77	1.70	✓

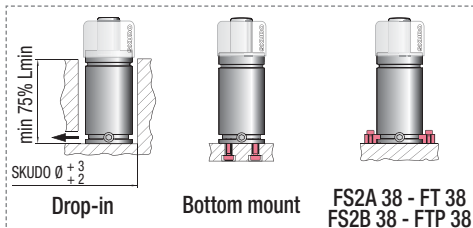
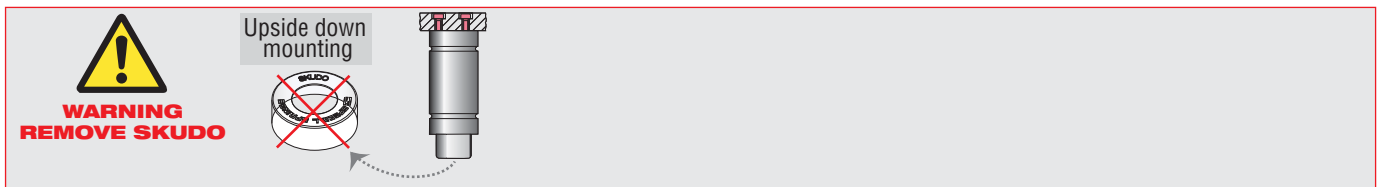

HOW TO ORDER

(10 pcs) RS 500-047-A
(10 pcs) RS 500-047-A-N

OSAS + OSM = OVER STROKE ACTIVE SAFETY + OVER STROKE MARKER

ACTIVE SAFETY

easu MANIFOLD p. 211



OSAS



USAS



OPAS



SKUDO

* F_{1i} =

Isothermal end force at 100% Cu p. 16

** F_{1p} =

Polytropic end force at 100% Cu p. 16

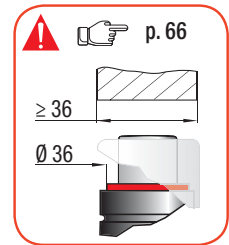
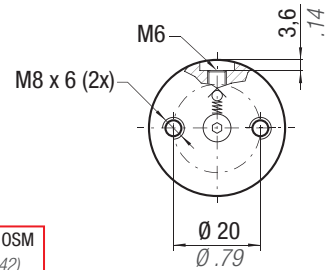
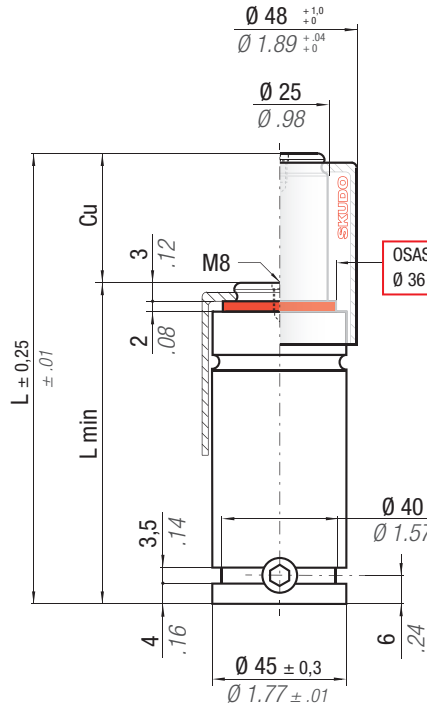
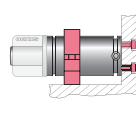
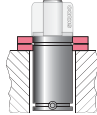

	°F 32 - 176	°C 0 - 80	ΔP ± 0,33 %/°C	P max 150 bar 2175 psi	P min 20 bar 290 psi	S 4,91 cm ² 0,761 in ²	SPM ~ 20 - 100 (at 20°C)	Max Speed 1,8 m/s	Maintenance kit 39BMRV00750C
--	----------------------	--------------------	---------------------------	-------------------------------------	-----------------------------------	---	---------------------------------------	-----------------------------	--

CODE	Cu		L		L min		F ₀		F _{1i} *		F _{1p} **		V ₀		PED		
	mm	inch	mm	inch	mm	inch	daN	lb	daN	lb	daN	lb	cm ³	in ³	~Kg	~lb	2014/68/EU
RS 750 - 007 - A	7	0.28	52	2.05	45	1.77	740 1664 ± 5% 150 bar 2175psi + 20 °C +68 °F		956	2148	1090	2450	18,0	1.10	0,36	0,79	✓
RS 750 - 010 - A	10	0.39	58	2.28	48	1.89			1006	2262	1166	2621	21,0	1.28	0,38	0,84	✓
RS 750 - 013 - A	13	0.51	64	2.52	51	2.01			1044	2347	1225	2754	25,0	1.53	0,39	0,86	✓
RS 750 - 016 - A	16	0.63	70	2.76	54	2.13			1074	2414	1272	2860	29,0	1.77	0,41	0,90	✓
RS 750 - 022 - A	22	0.87	82	3.23	60	2.36			1117	2511	1340	3012	37,0	2.26	0,45	0,99	✓
RS 750 - 029 - A	29	1.14	96	3.78	67	2.64			1151	2588	1395	3136	46,0	2.81	0,50	1,10	✓
RS 750 - 035 - A	35	1.38	108	4.25	73	2.87			1173	2636	1429	3213	53,0	3.23	0,54	1,19	✓
RS 750 - 047 - A	47	1.85	132	5.20	85	3.35			1202	2702	1477	3320	68,0	4.15	0,61	1,34	✓
RS 750 - 060 - A	60	2.36	158	6.22	98	3.86			1223	2748	1511	3397	85,0	5.19	0,70	1,54	✓
RS 750 - 072 - A	72	2.83	182	7.17	110	4.33			1236	2778	1533	3446	100,0	6.10	0,77	1,70	✓
RS 750 - 077 - A	77	3.03	192	7.56	115	4.53			1240	2788	1540	3462	107,0	6.53	0,81	1,79	✓
RS 750 - 097 - A	97	3.82	232	9.13	135	5.31			1254	2819	1563	3514	132,0	8.05	0,93	2,05	✓
RS 750 - 122 - A	122	4.80	282	11.10	160	6.30			1266	2845	1582	3556	164,0	10.00	1,10	2,43	✓

WARNING REMOVE SKUDO

Upside down mounting

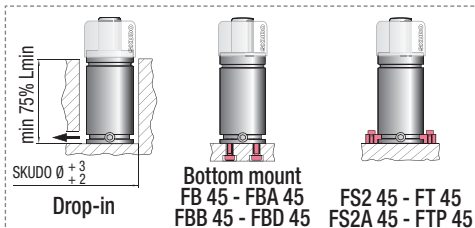

HOW TO ORDER

(10 pcs) RS 750-047-A
(10 pcs) RS 750-047-A-N

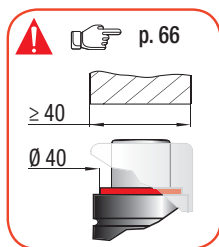
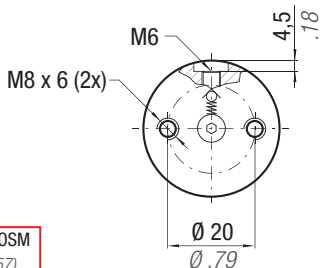
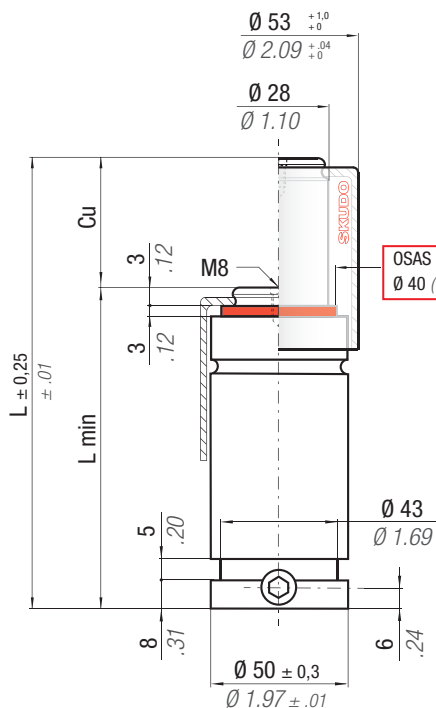

OSAS + OSM = OVER STROKE ACTIVE SAFETY + OVER STROKE MARKER

easu MANIFOLD p. 211

* F_{1i} =

Isothermal end force at 100% Cu p. 16

** F_{1p} =

Polytropic end force at 100% Cu

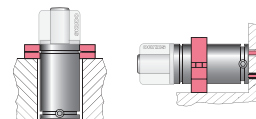

ACTIVE SAFETY



OSAS



USAS



OPAS



SKUDO

RS

	$^{\circ}\text{F}$ 32 - 176	$^{\circ}\text{C}$ 0 - 80	ΔP $\pm 0,33\% / ^{\circ}\text{C}$	P max 150 bar 2175 psi	P min 20 bar 290 psi	S 6,15 cm ² 0.953 in ²	SPM ~ 20 - 100 (at 20°C)	Max Speed 1,8 m/s	Maintenance kit 39BMRV01000C
--	--------------------------------------	------------------------------------	---	-------------------------------------	-----------------------------------	---	---------------------------------------	-----------------------------	--

CODE	Cu		L		L min		F ₀		F _{1i} *		F _{1p} **		V ₀		PED		
	mm	inch	mm	inch	mm	inch	daN	lb	daN	lb	daN	lb	cm ³	in ³	~Kg	~lb	2014/68/EU
RS 1000 - 010 - A	10	0.39	64	2.52	54	2.13	920 2068 ± 5% 150 bar 2175 psi + 20 °C +68 °F		1222	2748	1402	3152	29,0	1.77	0,51	1.12	✓
RS 1000 - 013 - A	13	0.51	70	2.76	57	2.24			1270	2856	1476	3318	34,0	2.07	0,54	1.19	✓
RS 1000 - 016 - A	16	0.63	76	2.99	60	2.36			1309	2943	1536	3453	39,0	2.38	0,56	1.23	✓
RS 1000 - 022 - A	22	0.87	88	3.46	66	2.60			1368	3075	1628	3660	48,0	2.93	0,61	1.34	✓
RS 1000 - 029 - A	29	1.14	102	4.02	73	2.87			1416	3183	1705	3833	59,0	3.60	0,67	1.48	✓
RS 1000 - 035 - A	35	1.38	114	4.49	79	3.11			1446	3252	1754	3943	69,0	4.21	0,71	1.57	✓
RS 1000 - 047 - A	47	1.85	138	5.43	91	3.58			1490	3349	1824	4101	88,0	5.37	0,81	1.79	✓
RS 1000 - 060 - A	60	2.36	164	6.46	104	4.09			1521	3419	1875	4215	108,0	6.59	0,91	2.01	✓
RS 1000 - 072 - A	72	2.83	188	7.40	116	4.57			1542	3466	1908	4289	127,0	7.75	1,05	2.31	✓
RS 1000 - 077 - A	77	3.03	198	7.80	121	4.76			1549	3481	1920	4316	135,0	8.24	1,09	2.40	✓
RS 1000 - 097 - A	97	3.82	238	9.37	141	5.55			1570	3530	1956	4397	166,0	10.13	1,21	2.67	✓
RS 1000 - 122 - A	122	4.80	288	11.34	166	6.54			1588	3571	1986	4465	205,0	12.51	1,41	3.11	✓

WARNING REMOVE SKUDO

Upside down mounting

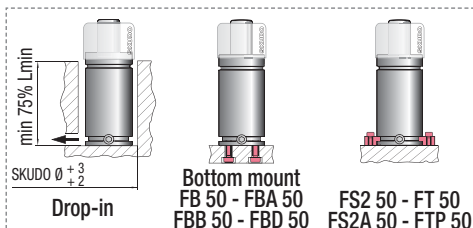

HOW TO ORDER

(10 pcs) RS 1000-047-A
(10 pcs) RS 1000-047-A-N

OSAS + OSM = OVER STROKE ACTIVE SAFETY + OVER STROKE MARKER

ACTIVE SAFETY

easu MANIFOLD p. 211



OSAS



USAS



OPAS



SKUDO

* F_{1i} =

Isothermal end force at 100% Cu p. 16

** F_{1p} =

Polytropic end force at 100% Cu

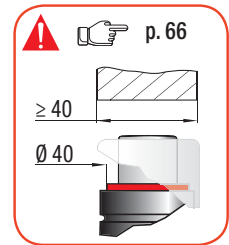
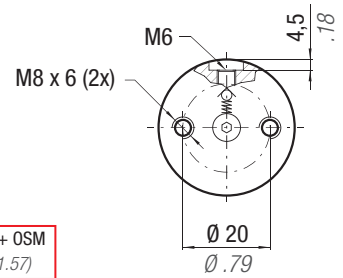
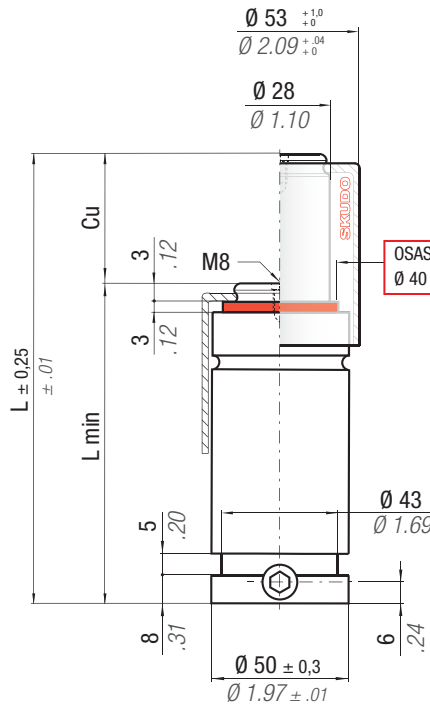
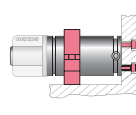
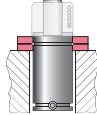

CODE		Cu		L		L min		F ₀		F _{1i} *		F _{1p} **		V ₀		Maintenance kit		
		mm	inch	mm	inch	mm	inch	daN	lb	daN	lb	daN	lb	cm ³	in ³	~Kg	~lb	
RS 1200 - 010 - A		10	0.39	64	2.52	54	2.13	1060 ± 5% 170 bar 2465 psi + 20 °C +68 °F	2383	1401	3150	1581	3554	30,0	1.83	0,51	1.12	39BMRV01000C
RS 1200 - 013 - A		13	0.51	70	2.76	57	2.24			1458	3278	1664	3741	34,0	2.07	0,54	1.19	
RS 1200 - 016 - A		16	0.63	76	2.99	60	2.36			1505	3383	1732	3893	39,0	2.38	0,56	1.23	
RS 1200 - 022 - A		22	0.87	88	3.46	66	2.60			1575	3540	1836	4127	48,0	2.93	0,61	1.34	
RS 1200 - 029 - A		29	1.14	102	4.02	73	2.87			1633	3670	1922	4321	59,0	3.60	0,67	1.48	
RS 1200 - 035 - A		35	1.38	114	4.49	79	3.11			1669	3753	1977	4445	69,0	4.21	0,71	1.57	
RS 1200 - 047 - A		47	1.85	138	5.43	91	3.58			1721	3870	2056	4622	88,0	5.37	0,81	1.79	
RS 1200 - 060 - A		60	2.36	164	6.46	104	4.09			1759	3954	2114	4752	108,0	6.59	0,91	2.01	
RS 1200 - 072 - A		72	2.83	188	7.40	116	4.57			1784	4010	2152	4837	127,0	7.75	1,05	2.31	
RS 1200 - 077 - A		77	3.03	198	7.80	121	4.76			1792	4029	2165	4866	135,0	8.24	1,09	2.40	
RS 1200 - 097 - A		97	3.82	238	9.37	141	5.55			1818	4087	2205	4957	166,0	10.13	1,21	2.67	
RS 1200 - 122 - A		122	4.80	288	11.34	166	6.54			1840	4136	2239	5033	205,0	12.51	1,41	3.11	

WARNING REMOVE SKUDO

Upside down mounting

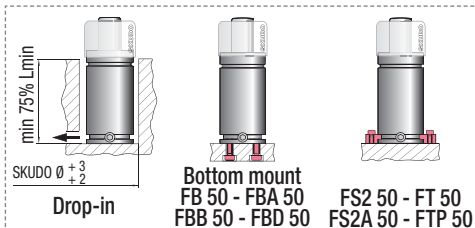

HOW TO ORDER

(10 pcs) RS 1200-047-A
(10 pcs) RS 1200-047-A-N

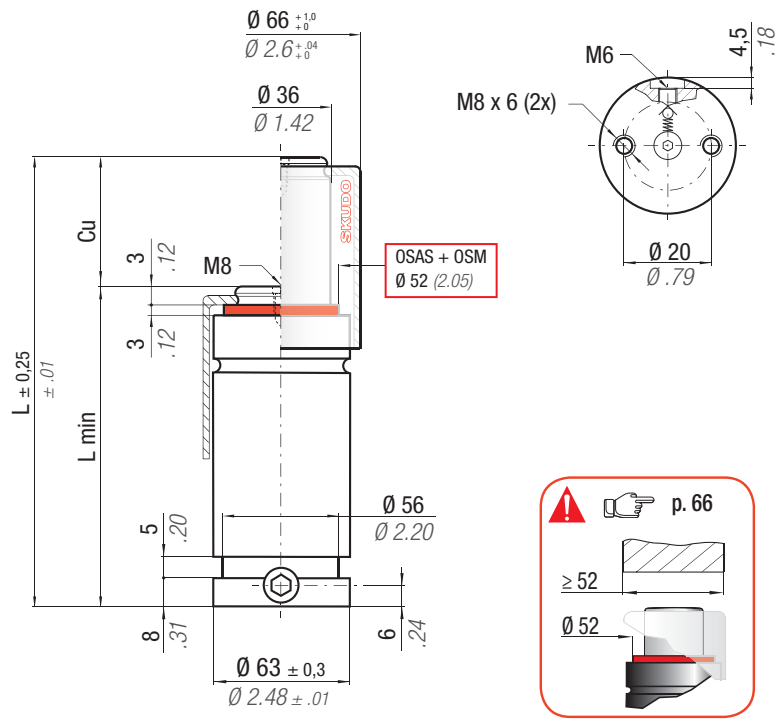

OSAS + OSM = OVER STROKE ACTIVE SAFETY + OVER STROKE MARKER

easu MANIFOLD p. 211

* F_{1i} = Isothermal end force at 100% Cu p. 16
 ** F_{1p} = Polyphotic end force at 100% Cu

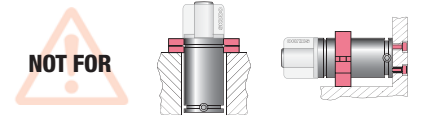

ACTIVE SAFETY

- OSAS
- USAS
- OPAS
- SKUDO

RS

	$^{\circ}F$ 32 - 176	$^{\circ}C$ 0 - 80	ΔP $\pm 0,33\% / ^{\circ}C$	P max 150 bar 2175 psi	P min 20 bar 290 psi	S 10,18 cm ² 1.578 in ²	SPM ~ 20 - 100 (at 20°C)	Max Speed 1,8 m/s	Maintenance kit 39BMRV01500C
--	-------------------------	-----------------------	--	-------------------------------------	-----------------------------------	--	---------------------------------------	-----------------------------	--

CODE	Cu		L		L min		F ₀ Initial force		F _{1i} * End force		F _{1p} ** End force		V ₀		PED 2014/68/EU		
	mm	inch	mm	inch	mm	inch	daN	lb	daN	lb	daN	lb	cm ³	in ³	~Kg	~lb	
RS 1500 - 010 - A	10	0.39	70	2.76	60	2.36	1530 ± 5% 150 bar 2175 psi + 20 °C +68 °F	3440	1970	4428	2241	5038	53,0	3.23	0,92	2,03	✓
RS 1500 - 013 - A	13	0.51	76	2.99	63	2.48			2045	4597	2355	5294	61,0	3.72	0,96	2.12	✓
RS 1500 - 016 - A	16	0.63	82	3.23	66	2.60			2106	4735	2450	5508	69,0	4.21	0,99	2.18	✓
RS 1500 - 022 - A	22	0.87	94	3.70	72	2.83			2201	4947	2596	5836	85,0	5.19	1,06	2.34	✓
RS 1500 - 029 - A	29	1.14	108	4.25	79	3.11			2279	5124	2720	6115	103,0	6.28	1,14	2.51	✓
RS 1500 - 035 - A	35	1.38	120	4.72	85	3.35			2330	5238	2801	6297	119,0	7.26	1,21	2.67	✓
RS 1500 - 047 - A	47	1.85	144	5.67	97	3.82			2402	5401	2917	6558	151,0	9.21	1,35	2.98	✓
RS 1500 - 060 - A	60	2.36	170	6.69	110	4.33			2455	5520	3003	6751	186,0	11.35	1,51	3.33	✓
RS 1500 - 072 - A	72	2.83	194	7.64	122	4.80			2490	5599	3060	6879	217,0	13.24	1,65	3.64	✓
RS 1500 - 077 - A	77	3.03	204	8.03	127	5.00			2502	5625	3079	6922	231,0	14.09	1,71	3.77	✓
RS 1500 - 097 - A	97	3.82	244	9.61	147	5.79			2540	5709	3141	7061	284,0	17.32	1,94	4.28	✓
RS 1500 - 122 - A	122	4.80	294	11.57	172	6.77			2571	5780	3193	7178	350,0	21.35	2,23	4.92	✓

WARNING REMOVE SKUDO

Upside down mounting

Drop-in SKUDO $\varnothing \pm \frac{3}{2}$

Bottom mount - FB 50 FS2 63 - FS2A 63
 FBA 50 - FBD 50 FS2B 63 - FT 63
 FB 63 - FBB 63 FTP 63

HOW TO ORDER

(10 pcs) RS 1500-047-A
 (10 pcs) RS 1500-047-A-N

OSAS + OSM = OVER STROKE ACTIVE SAFETY + OVER STROKE MARKER

ACTIVE SAFETY



p. 211



OSAS



USAS



OPAS



SKUDO

* F_{1i} =

Isothermal end force at 100% Cu

p. 16

** F_{1p} =

Polytropic end force at 100% Cu

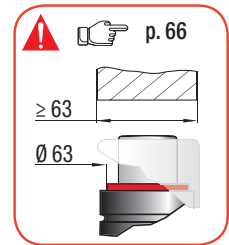
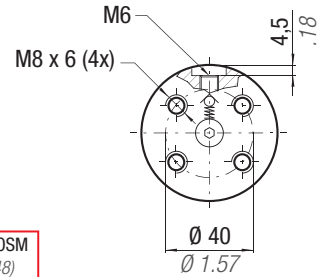
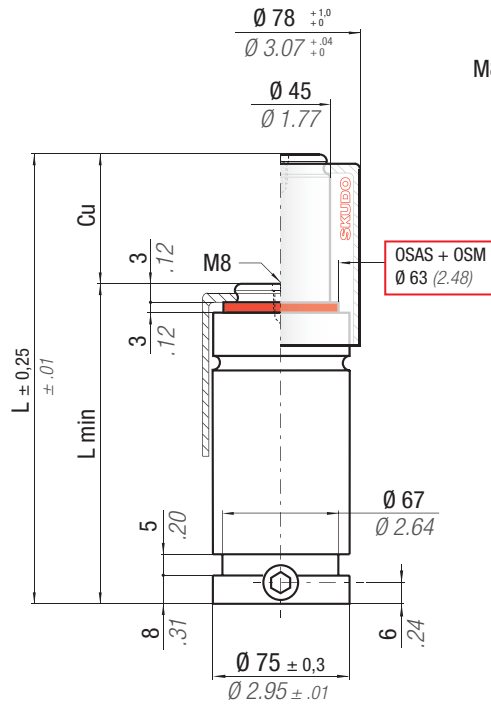
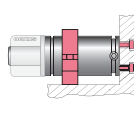
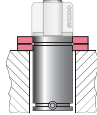

	$^{\circ}\text{F}$ 32 - 176	$^{\circ}\text{C}$ 0 - 80	ΔP ± 0,33 %/°C	P max 150 bar 2175 psi	P min 20 bar 290 psi	S 15,90 cm ² 2.465 in ²	SPM ~ 20 - 100 (at 20°C)	Max Speed 1,8 m/s	Maintenance kit 39BMRV02400C
--	--------------------------------------	------------------------------------	---------------------------------	-------------------------------------	-----------------------------------	--	---------------------------------------	-----------------------------	--

CODE	Cu		L		L min		F ₀		F _{1i} *		F _{1p} **		V ₀		~Kg		~lb		PED 2014/68/EU	
	mm	inch	mm	inch	mm	inch	daN	lb	daN	lb	daN	lb	cm ³	in ³						
RS 2400 - 013 - A	13	0.51	77	3.03	64	2.52	2385 ± 5%	5362	3220	7238	3718	8358	93,0	5.67	1,36	3,00	✓			
RS 2400 - 016 - A	16	0.63	83	3.27	67	2.64			3320	7465	3873	8707	105,0	6.41	1,40	3,09	✓			
RS 2400 - 022 - A	22	0.87	95	3.74	73	2.87			3476	7814	4115	9251	129,0	7.87	1,50	3,31	✓			
RS 2400 - 029 - A	29	1.14	109	4.29	80	3.15			3606	8107	4322	9716	157,0	9.58	1,61	3,55	✓			
RS 2400 - 035 - A	35	1.38	121	4.76	86	3.39			3690	8296	4456	10017	181,0	11.04	1,70	3,75	✓			
RS 2400 - 047 - A	47	1.85	145	5.71	98	3.86			150 bar	3811	8568	4651	10456	230,0	14.03	1,89	4,17	✓		
RS 2400 - 060 - A	60	2.36	171	6.73	111	4.37			2175 psi	3900	8768	4796	10782	282,0	17.20	2,09	4,61	✓		
RS 2400 - 072 - A	72	2.83	195	7.68	123	4.84			+ 20 °C	3959	8900	4892	10998	330,0	20.13	2,28	5,03	✓		
RS 2400 - 077 - A	77	3.03	205	8.07	128	5.04			+ 68 °F	3979	8946	4925	11072	350,0	21.35	2,36	5,20	✓		
RS 2400 - 097 - A	97	3.82	245	9.65	148	5.83				4042	9087	5029	11306	431,0	26.29	2,67	5,89	✓		
RS 2400 - 122 - A	122	4.80	295	11.61	173	6.81		4096	9207	5117	11503	532,0	32.45	3,07	6,77	✓				

WARNING REMOVE SKUDO

Upside down mounting

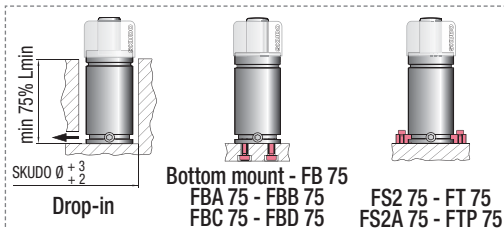

HOW TO ORDER

(10 pcs) RS 2400-047-A
(10 pcs) RS 2400-047-A-N

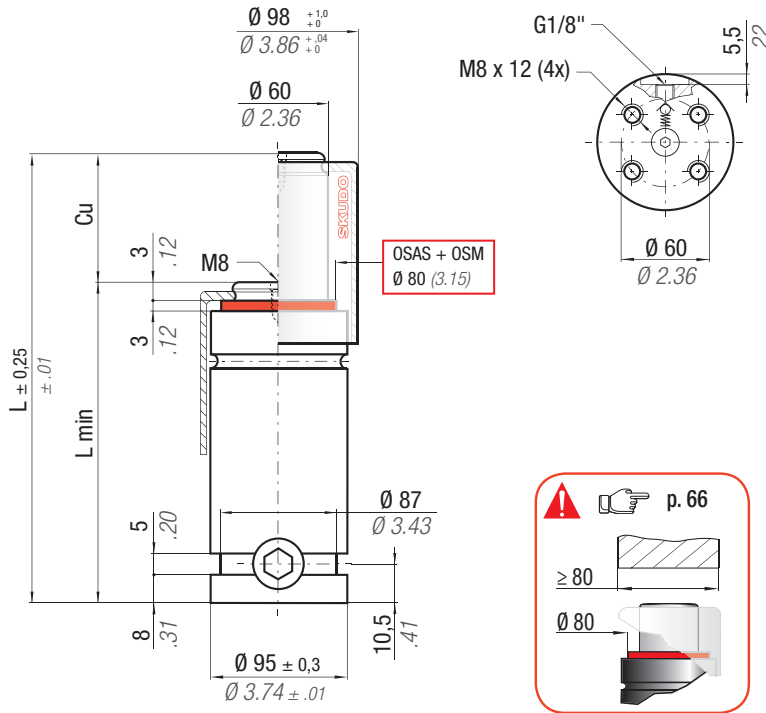

OSAS + OSM = OVER STROKE ACTIVE SAFETY + OVER STROKE MARKER

easu MANIFOLD p. 211

* F_{1i} =

Isothermal end force at 100% Cu p. 16

** F_{1p} =

Polytropic end force at 100% Cu

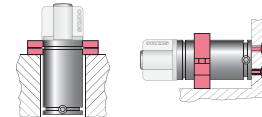

ACTIVE SAFETY



OSAS



USAS



OPAS



SKUDO

RS

	$^{\circ}F$ 32 - 176	$^{\circ}C$ 0 - 80	ΔP $\pm 0,33\%/^{\circ}C$	P max 150 bar 2175 psi	P min 20 bar 290 psi	S 28,27 cm ² 4.382 in ²	SPM ~ 20 - 100 (at 20°C)	Max Speed 1,8 m/s	Maintenance kit 39BMRV04200C
--	-------------------------------	-----------------------------	--------------------------------------	-------------------------------------	-----------------------------------	--	---------------------------------------	-----------------------------	--

CODE	Cu		L		L min		F ₀ Initial force		F _{1i} * End force *		F _{1p} ** End force **		V ₀		PED 2014/68/EU		
	mm	inch	mm	inch	mm	inch	daN	lb	daN	lb	daN	lb	cm ³	in ³	~Kg	~lb	
RS 4200 - 013 - A	13	0.51	90	3.54	77	3.03	4240 $\pm 5\%$ 150 bar 2175 psi + 20 °C +68 °F	9532	5633	12664	6471	14547	173,0	10.55	2,76	6.08	✓
RS 4200 - 016 - A	16	0.63	96	3.78	80	3.15			5823	13090	6761	15199	194,0	11.83	2,83	6.24	✓
RS 4200 - 022 - A	22	0.87	108	4.25	86	3.39			6125	13771	7232	16258	234,0	14.27	2,98	6.57	✓
RS 4200 - 029 - A	29	1.14	122	4.80	93	3.66			6390	14365	7650	17198	281,0	17.14	3,16	6.97	✓
RS 4200 - 035 - A	35	1.38	134	5.28	99	3.90			6566	14761	7931	17830	322,0	19.64	3,30	7.28	✓
RS 4200 - 047 - A	47	1.85	158	6.22	111	4.37			6827	15347	8351	18774	403,0	24.58	3,60	7.94	✓
RS 4200 - 060 - A	60	2.36	184	7.24	124	4.88			7024	15790	8673	19498	491,0	29.95	3,93	8.66	✓
RS 4200 - 072 - A	72	2.83	208	8.19	136	5.35			7158	16091	8893	19992	572,0	34.89	4,20	9.26	✓
RS 4200 - 077 - A	77	3.03	218	8.58	141	5.55			7204	16195	8970	20165	606,0	36.97	4,35	9.59	✓
RS 4200 - 097 - A	97	3.82	258	10.16	161	6.34			7350	16524	9212	20709	741,0	45.20	4,85	10.69	✓
RS 4200 - 122 - A	122	4.80	308	12.13	186	7.32	7476	16807	9423	21184	910,0	55.51	5,47	12.06	✓		

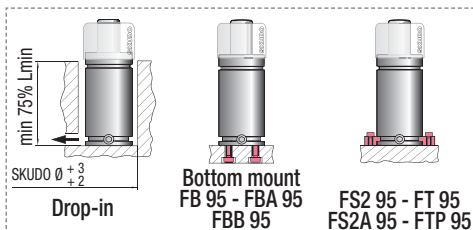
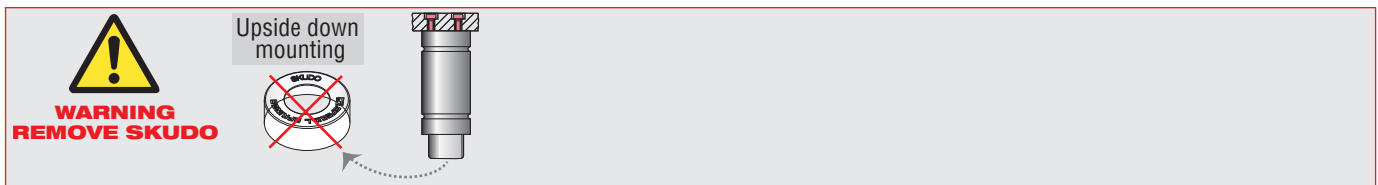

HOW TO ORDER

(10 pcs) RS 4200-047-A
(10 pcs) RS 4200-047-A-N

OSAS + OSM = OVER STROKE ACTIVE SAFETY + OVER STROKE MARKER

ACTIVE SAFETY

easyl MANIFOLD p. 211



OSAS



USAS



OPAS



SKUDO

* F_{1i} =

Isothermal end force at 100% Cu p. 16

** F_{1p} =

Polytropic end force at 100% Cu



NOT FOR

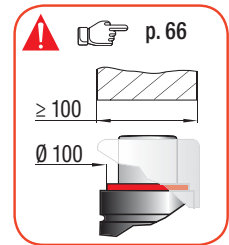
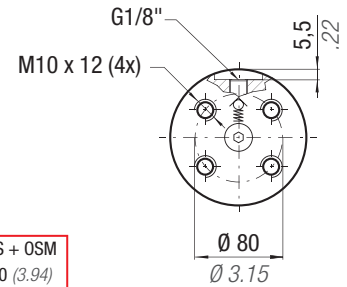
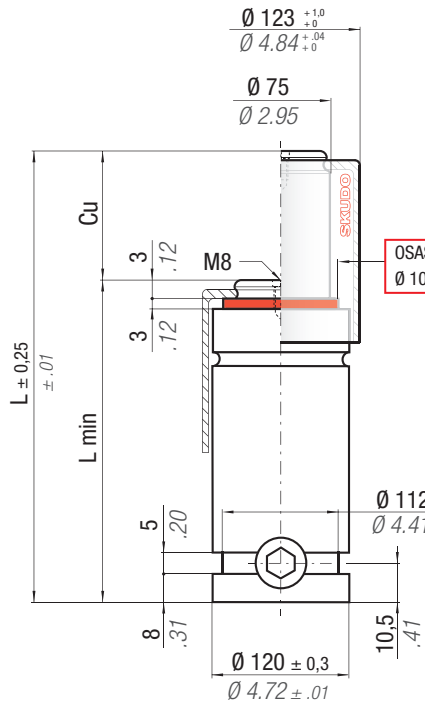
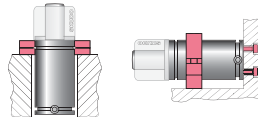

	$^{\circ}F$ 32 - 176	$^{\circ}C$ 0 - 80	ΔP $\pm 0,33 \% / ^{\circ}C$	P max 150 bar 2175 psi	P min 20 bar 290 psi	S 44,18 cm ² 6.848 in ²	SPM ~ 20 - 100 (at 20°C)	Max Speed 1,8 m/s	Maintenance kit 39BMRV06600C
--	-------------------------------	-----------------------------	---	-------------------------------------	-----------------------------------	--	---------------------------------------	-----------------------------	--

CODE		Cu		L		L min		F ₀		F _{1i} *		F _{1p} **		V ₀				
		mm	inch	mm	inch	mm	inch	daN	lb	daN	lb	daN	lb	cm ³	in ³		~Kg	~lb
RS 6600 - 013 - A		13	0.51	100	3.94	87	3.43	6630 $\pm 5\%$ 14904		8535	19187	9705	21818	300,0	18.30	5,06	11.16	✓
RS 6600 - 016 - A		16	0.63	106	4.17	90	3.54			8812	19811	10127	22766	332,0	20.25	5,17	11.40	✓
RS 6600 - 022 - A		22	0.87	118	4.65	96	3.78			9265	20829	10824	24333	396,0	24.16	5,42	11.95	✓
RS 6600 - 029 - A		29	1.14	132	5.20	103	4.06			9671	21742	11458	25759	471,0	28.73	5,69	12.54	✓
RS 6600 - 035 - A		35	1.38	144	5.67	109	4.29			9946	22360	11892	26734	535,0	32.64	5,93	13.07	✓
RS 6600 - 047 - A		47	1.85	168	6.61	121	4.76			10362	23296	12557	28229	663,0	40.44	6,40	14.11	✓
RS 6600 - 060 - A		60	2.36	194	7.64	134	5.28			10684	24018	13077	29398	802,0	48.92	6,90	15.21	✓
RS 6600 - 072 - A		72	2.83	218	8.58	146	5.75			10905	24515	13438	30210	930,0	56.73	7,40	16.31	✓
RS 6600 - 077 - A		77	3.03	228	8.98	151	5.94			10982	24689	13564	30493	983,0	59.96	7,60	16.76	✓
RS 6600 - 097 - A		97	3.82	268	10.55	171	6.73			11229	25243	13970	31406	1197,0	73.02	8,40	18.52	✓
RS 6600 - 122 - A		122	4.80	318	12.52	196	7.72	11443	25726	14326	32206	1464,0	89.30	9,40	20.72	✓		

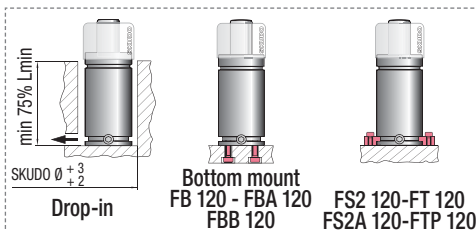
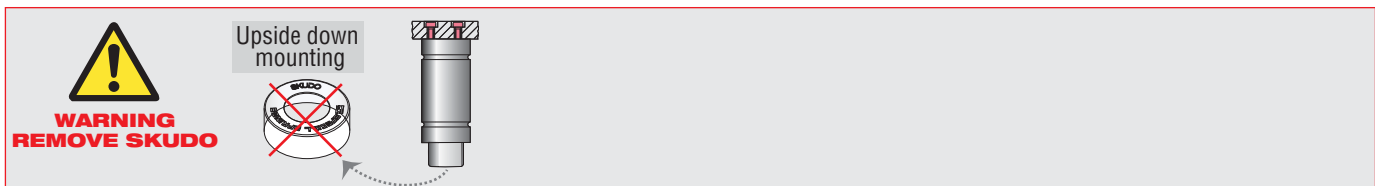

HOW TO ORDER

(10 pcs) RS 6600-047-A
(10 pcs) RS 6600-047-A-N

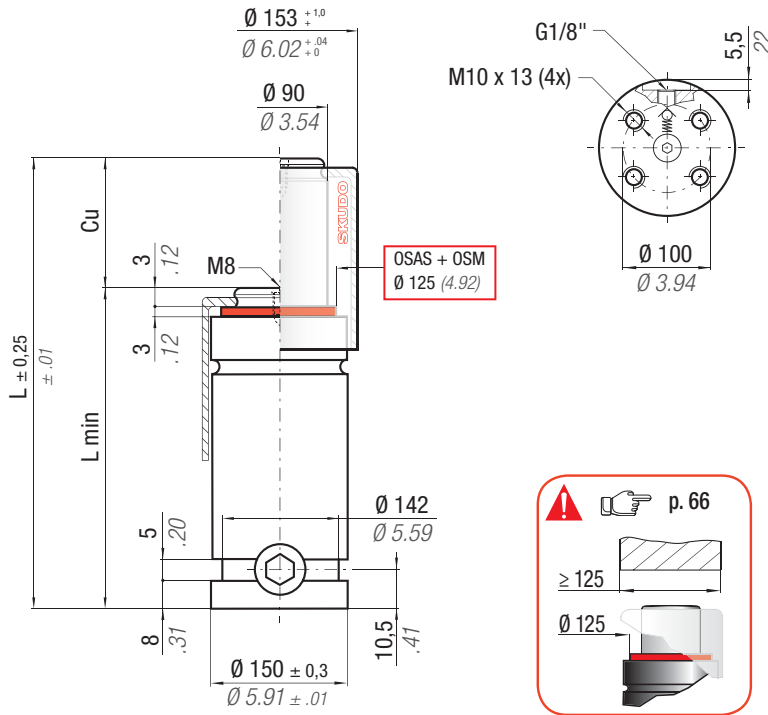

OSAS + OSM = OVER STROKE ACTIVE SAFETY + OVER STROKE MARKER

easu MANIFOLD p. 211

* F_{1i} = Isothermal end force at 100% Cu p. 16

** F_{1p} = Polytrophic end force at 100% Cu

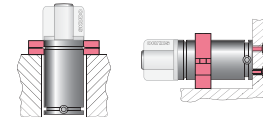

ACTIVE SAFETY



OSAS



USAS



OPAS



SKUDO

RS

	$^{\circ}\text{F}$ 32 - 176	$^{\circ}\text{C}$ 0 - 80	ΔP $\pm 0,33\% / ^{\circ}\text{C}$	P max 150 bar 2175 psi	P min 20 bar 290 psi	S 63,62 cm ² 9.861 in ²	SPM ~ 20 - 100 (at 20°C)	Max Speed 1,8 m/s	Maintenance kit 39BMRV09500C
--	--------------------------------------	------------------------------------	---	-------------------------------------	-----------------------------------	--	---------------------------------------	-----------------------------	--

CODE	Cu		L		L min		F ₀ Initial force		F _{1i} * End force *		F _{1p} ** End force **		V ₀		PED 2014/68/EU		
	mm	inch	mm	inch	mm	inch	daN	lb	daN	lb	daN	lb	cm ³	in ³	~Kg	~lb	✓
RS 9500 - 016 - A	16	0.63	116	4.57	100	3.94			12388	27849	14124	31752	517,0	31.54	9,51	20.97	✓
RS 9500 - 022 - A	22	0.87	128	5.04	106	4.17			12985	29192	15035	33800	614,0	37.45	9,90	21.83	✓
RS 9500 - 029 - A	29	1.14	142	5.59	113	4.45	9540	21446	13523	30401	15867	35670	727,0	44.35	10,30	22.71	✓
RS 9500 - 035 - A	35	1.38	154	6.06	119	4.69	$\pm 5\%$		13888	31222	16439	36956	823,0	50.20	10,70	23.59	✓
RS 9500 - 047 - A	47	1.85	178	7.01	131	5.16			14443	32470	17317	38930	1017,0	62.04	11,40	25.13	✓
RS 9500 - 060 - A	60	2.36	204	8.03	144	5.67	150 bar	2175 psi	14873	33436	18004	40475	1226,0	74.79	12,20	26.90	✓
RS 9500 - 072 - A	72	2.83	228	8.98	156	6.14			15170	34104	18483	41551	1420,0	86.62	13,00	28.66	✓
RS 9500 - 077 - A	77	3.03	238	9.37	161	6.34	+ 20 °C	+68 °F	15274	34337	18651	41929	1500,3	91.52	13,30	29.32	✓
RS 9500 - 097 - A	97	3.82	278	10.94	181	7.13			15606	35083	19191	43143	1823,0	111.20	14,60	32.19	✓
RS 9500 - 122 - A	122	4.80	328	12.91	206	8.11			15896	35735	19666	44211	2226,0	135.79	16,10	35.49	✓

WARNING REMOVE SKUDO

Upside down mounting

HOW TO ORDER

(10 pcs) RS 9500-047-A
(10 pcs) RS 9500-047-A-N

Drop-in: SKUDO $\varnothing \pm 0.03 \pm 0.02$

Bottom mount: FB 150 - FBA 150, FBB 150 - FBD 150, FS2 150-FT 150, FS2A 150-FTP 150

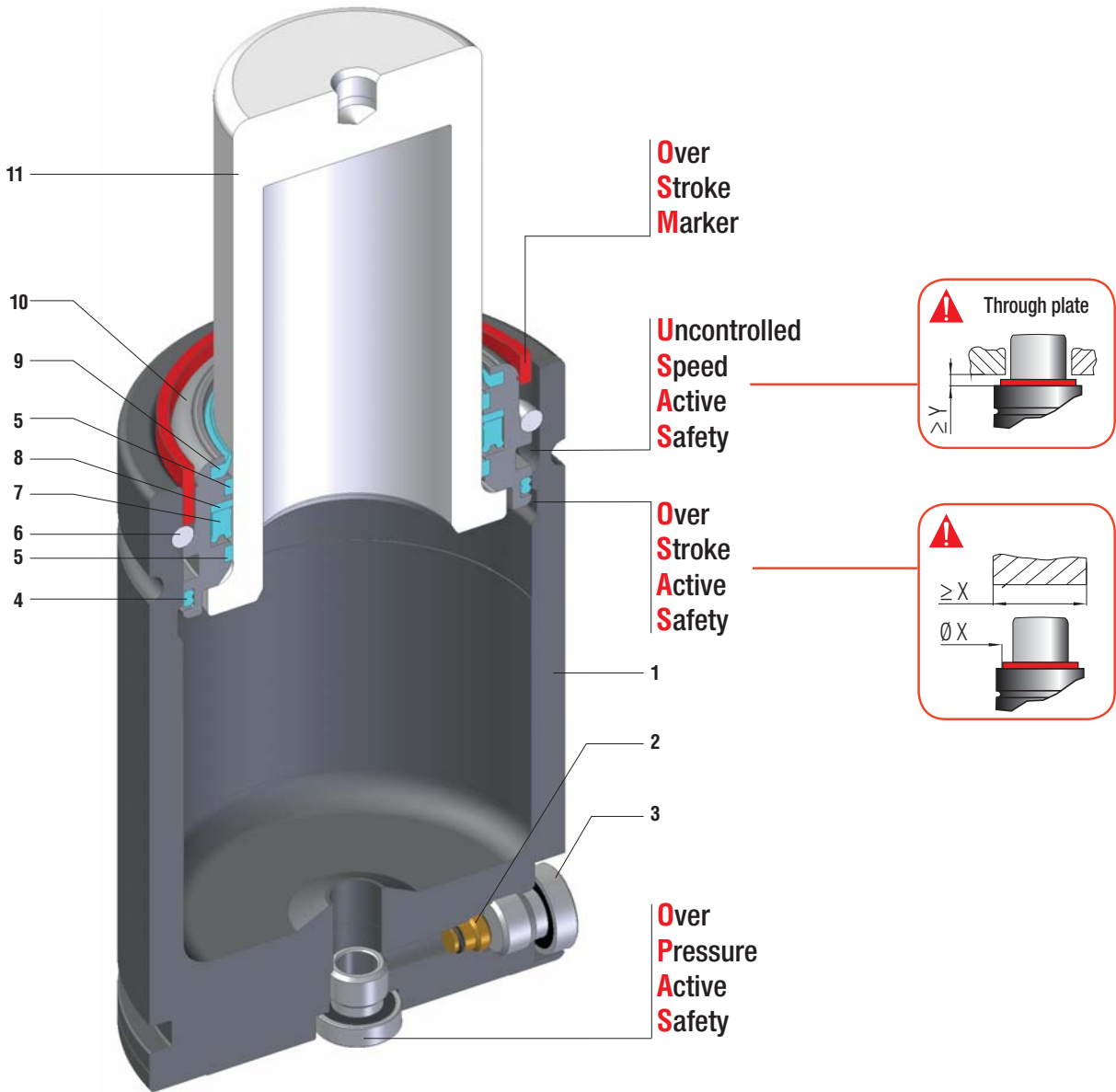

Minima altezza, massima forza, collegabili G1/8 - Minimum height, maximum force, hose cylinders with G1/8 charging port - Minimale Höhe, maximale Kraft, Gdf. mit G1/8 Öffnung verbindbar - Hauteur minimale, force maximale, cylindres raccordés avec trou G1/8 gaz - Mínima altura, máxima fuerza, cilindros conectados con agujero G1/8 gas - Altura mínima, força máxima, cilindros conectados com furo G1/8 gás

SEALING	ROD SEAL
DESIGN	BUSH - BODY DESIGN

1	Body	5	Guide ring	9	Rod wiper
2	Valve	6	Retaining ring	10	Bush
3	Plug	7	Rod seal	11	Rod (nitrited superfinished)
4	Dual ring seal	8	Back-up ring		

RANGE CHART

Model	Body Ø		Stroke Cu		Initial force F0		OSAS	USAS	OPAS	SKUDO
	mm	inch	mm	inch	daN	lb				
RF 750	45	1.77	10 - 125	0.39 - 4.92	740	1664	✓	✓	✓	-
RF 1000	50	1.97	13 - 125	0.51 - 4.92	920	2068	✓	✓	✓	-
RF 1200	50	1.97	13 - 125	0.51 - 4.92	1060	2383	✓	✓	✓	-
RF 1500	63	2.48	13 - 125	0.51 - 4.92	1530	3440	✓	✓	✓	-
RF 2400	75	2.95	16 - 125	0.63 - 4.92	2385	5362	✓	✓	✓	-
	95	3.74								
	120	4.72								
	150	5.91								
	150	5.91								
	195	7.68								

RV series

RF



HOW TO ORDER

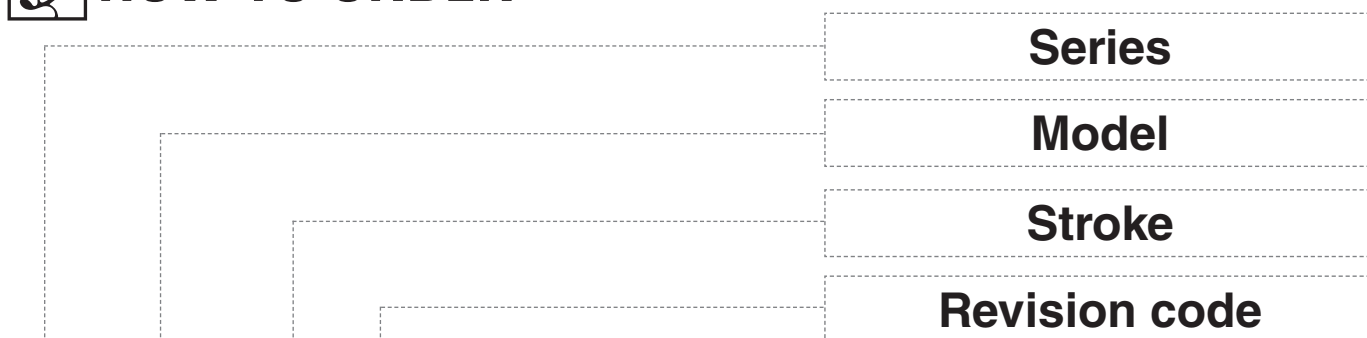

RF 2400-050-A - N - E

IT Codice cilindro autonomo
EN Self-contained cylinder code
DE Kode des eingeständigen Gdf.
FR Code du cylindre autonome
ES Código del cilindro autónomo
PT Código do cilindro autónomo

IT Collegabile con tubi, cilindro fornito scarico e senza valvola unidirezionale
EN Linkable with hoses, cylinder supplied without pressure and oneway valve
DE Anschlussfähig mit Leitungen, Gdf. geliefert ohne Druck und RückschlagVentil
FR Connectable avec tubes, ressort fourni sans pression ni valve unidirectionelle
ES Connectable con tubos, cilindro suministrado sin presión y sin válvula unidireccional
PT Acompláveis com tubos, cilindro fornecidos sem pressão e sem válvula unidireccional

IT Collegabile EASY MANIFOLD, fornito scarico + guarnizione di collegamento
EN Linkable EASY MANIFOLD, supplied without pressure + connecting seal
DE Anschlussfähig EASY MANIFOLD, geliefert ohne Druck + Verbindungsdichtung
FR Connectable EASY MANIFOLD, fourni sans pression + joint de connexion
ES Connectable EASY MANIFOLD, suministrado sin presión + junta de conexión
PT Acompláveis EASY MANIFOLD, fornecidos sem pressão + vedantes de conexão

OSAS + OSM = OVER STROKE ACTIVE SAFETY + OVER STROKE MARKER

ACTIVE SAFETY



OSAS



USAS



OPAS

* F_{1i} =
Isothermal
end force
at 100% Cu



p. 16



** F_{1p} =
Polytrophic
end force
at 100% Cu

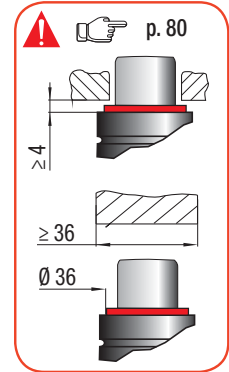
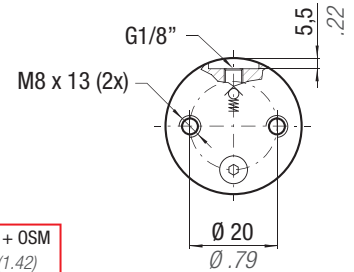
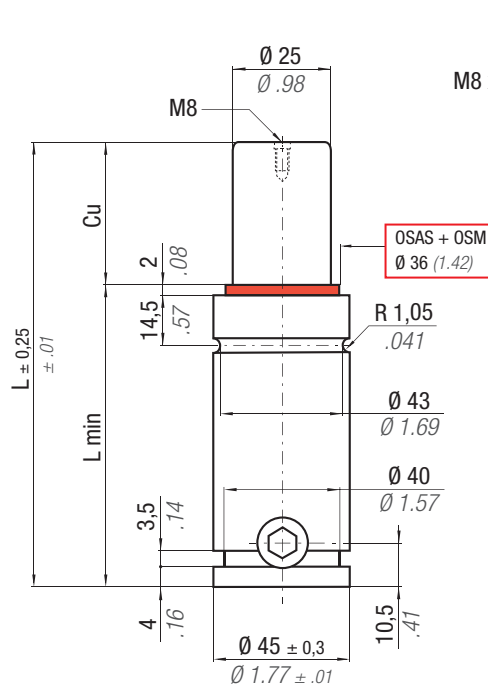

CODE	N ₂	°F 32 - 176	°C 0 - 80	ΔP ± 0,33 %/°C	P max 150 bar 2175 psi	P min 20 bar 290 psi	S 4,91 cm ² 0,761 in ²	SPM ~ 20 - 100 (at 20°C)	Max Speed 1,8 m/s	Maintenance kit 39BMRV00750C	Vo		PED		
											cm ³	in ³	~Kg	~lb	2014/68/EU
RF 750 - 010 - A											18,0	1,10	0,47	1,04	✓
RF 750 - 013 - A											21,0	1,28	0,48	1,06	✓
RF 750 - 016 - A											25,0	1,53	0,50	1,10	✓
RF 750 - 019 - A											29,0	1,77	0,52	1,15	✓
RF 750 - 025 - A											37,0	2,26	0,56	1,23	✓
RF 750 - 032 - A											46,0	2,81	0,61	1,34	✓
RF 750 - 038 - A											53,0	3,23	0,65	1,43	✓
RF 750 - 050 - A											68,0	4,15	0,72	1,59	✓
RF 750 - 063 - A											85,0	5,19	0,81	1,79	✓
RF 750 - 075 - A											100,0	6,10	0,88	1,94	✓
RF 750 - 080 - A											107,0	6,53	0,92	2,03	✓
RF 750 - 100 - A											132,0	8,05	1,04	2,29	✓
RF 750 - 125 - A											164,0	10,00	1,21	2,67	✓

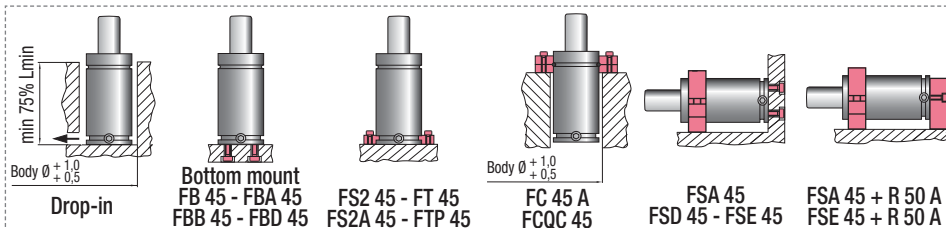

HOW TO ORDER
(10 pcs) RF 750-050-A
(10 pcs) RF 750-050-A-N

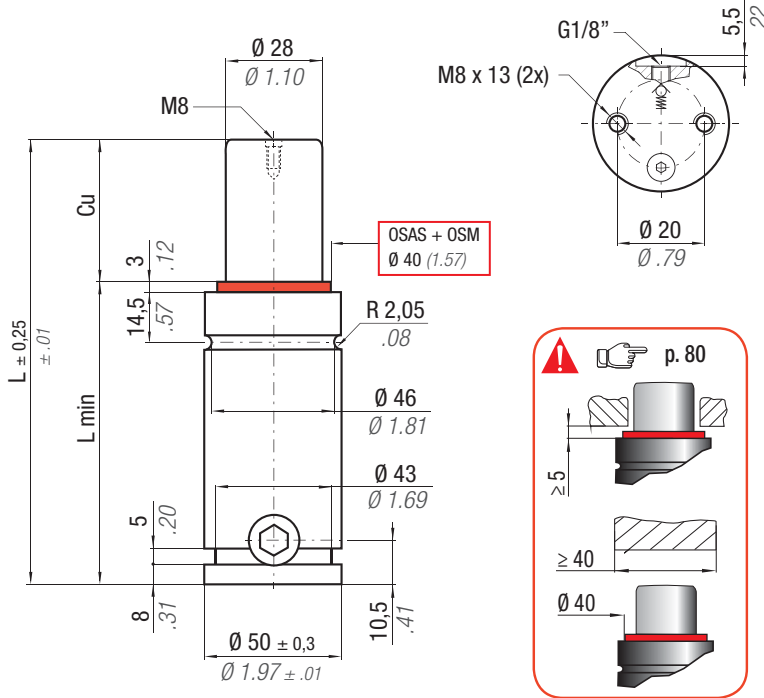

OSAS + OSM = OVER STROKE ACTIVE SAFETY + OVER STROKE MARKER

* F_{1i} = Isothermal end force at 100% Cu

** F_{1p} = Polyphotic end force at 100% Cu

ACTIVE SAFETY



OSAS



USAS



OPAS

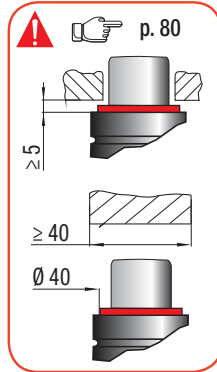

RF

CODE	Cu		L		L min		F ₀		F _{1i} *		F _{1p} **		V ₀		Maintenance kit		
	mm	inch	mm	inch	mm	inch	daN	lb	daN	lb	daN	lb	cm ³	in ³	~Kg	~lb	
RF 1000 - 013 - A	13	0.51	74	2.91	61	2.40	920 2068 ± 5% 150 bar 2175 psi + 20 °C + 68 °F		1349	3033	1599	3595	29,0	1.77	0,65	1,43	✓
RF 1000 - 016 - A	16	0.63	80	3.15	64	2.52			1386	3117	1658	3727	34,0	2.07	0,68	1.50	✓
RF 1000 - 019 - A	19	0.75	86	3.39	67	2.64			1416	3183	1705	3833	39,0	2.38	0,70	1.54	✓
RF 1000 - 025 - A	25	0.98	98	3.86	73	2.87			1460	3282	1775	3990	48,0	2.93	0,75	1.65	✓
RF 1000 - 032 - A	32	1.26	112	4.41	80	3.15			1495	3361	1832	4118	59,0	3.60	0,81	1.79	✓
RF 1000 - 038 - A	38	1.50	124	4.88	86	3.39			1517	3410	1868	4199	69,0	4.21	0,85	1.87	✓
RF 1000 - 050 - A	50	1.97	148	5.83	98	3.86			1548	3479	1919	4314	88,0	5.37	0,95	2.09	✓
RF 1000 - 063 - A	63	2.48	174	6.85	111	4.37			1570	3528	1955	4395	108,0	6.59	1,05	2.31	✓
RF 1000 - 075 - A	75	2.95	198	7.80	123	4.84			1584	3560	1978	4447	127,0	7.75	1,15	2.54	✓
RF 1000 - 080 - A	80	3.15	208	8.19	128	5.04			1589	3571	1986	4465	135,0	8.24	1,19	2.62	✓
RF 1000 - 100 - A	100	3.94	248	9.76	148	5.83			1603	3604	2011	4521	166,0	10.13	1,35	2.98	✓
RF 1000 - 125 - A	125	4.92	298	11.73	173	6.81			1616	3632	2031	4566	205,0	12.51	1,55	3.42	✓

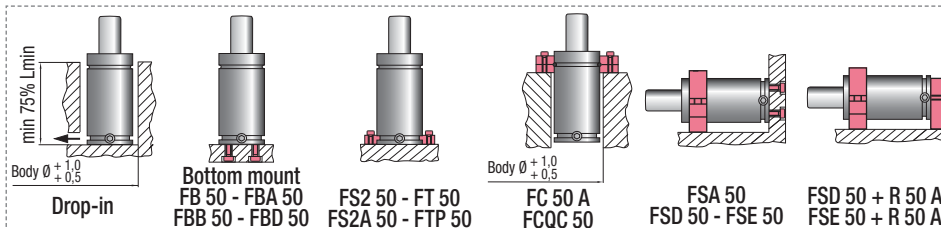

HOW TO ORDER

(10 pcs) RF 1000-050-A
(10 pcs) RF 1000-050-A-N

OSAS + OSM = OVER STROKE ACTIVE SAFETY + OVER STROKE MARKER

ACTIVE SAFETY



OSAS



USAS



OPAS

* F_{1i} =

Isothermal end force at 100% Cu



p. 16



** F_{1p} =

Polytrophic end force at 100% Cu

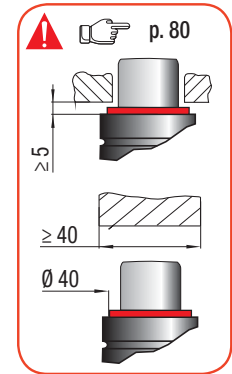
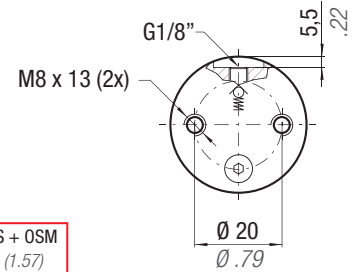
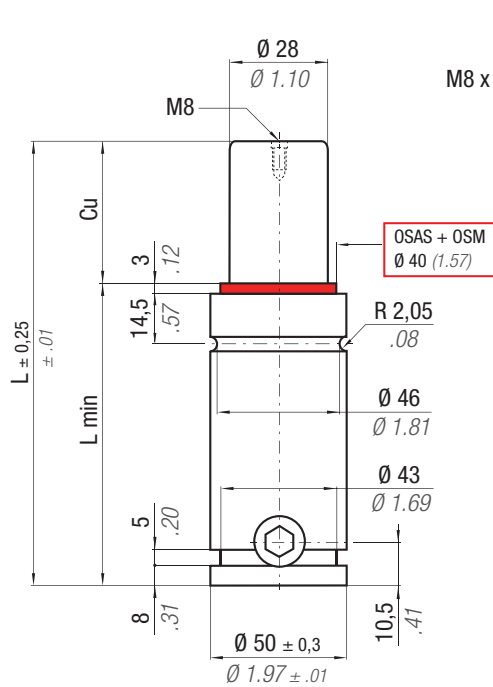

CODE	N ₂	°F 32 - 176	°C 0 - 80	ΔP ± 0,33 %/°C	P max 170 bar 2465 psi	P min 20 bar 290 psi	S 6,15 cm ² 0,953 in ²	SPM ~ 20 - 100 (at 20°C)	Max Speed 1,8 m/s	Maintenance kit 39BMRV01000C	PED	
											2014/68/EU	✓
RF 1200 - 013 - A												✓
RF 1200 - 016 - A												✓
RF 1200 - 019 - A												✓
RF 1200 - 025 - A												✓
RF 1200 - 032 - A												✓
RF 1200 - 038 - A												✓
RF 1200 - 050 - A												✓
RF 1200 - 063 - A												✓
RF 1200 - 075 - A												✓
RF 1200 - 080 - A												✓
RF 1200 - 100 - A												✓
RF 1200 - 125 - A												✓

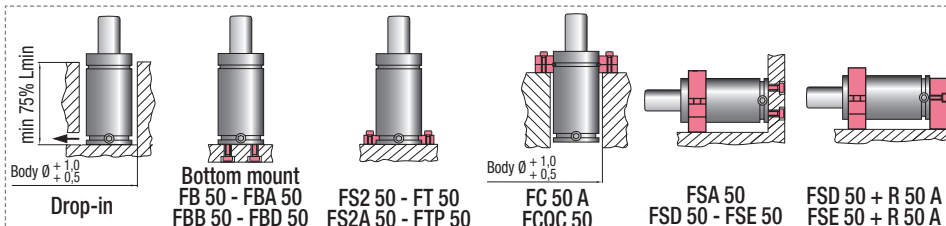

HOW TO ORDER

(10 pcs) RF 1200-050-A
(10 pcs) RF 1200-050-A-N

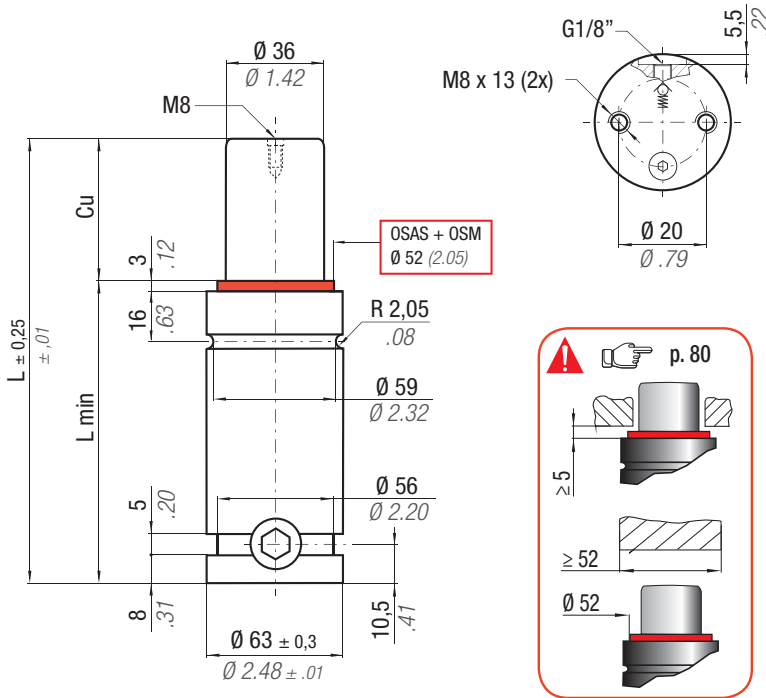

OSAS + OSM = OVER STROKE ACTIVE SAFETY + OVER STROKE MARKER

* F_{1i} = Isothermal end force at 100% Cu p. 16
 ** F_{1p} = Polytropic end force at 100% Cu

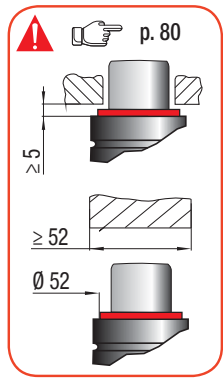

RF

CODE	Cu		L		L min		F ₀		F _{1i} *		F _{1p} **		V ₀		Maintenance kit		
	mm	inch	mm	inch	mm	inch	daN	lb	daN	lb	daN	lb	cm ³	in ³	~Kg	~lb	
RF 1500 - 013 - A	13	0.51	80	3.15	67	2.64	1530 3440 ± 5% 150 bar 2175 psi + 20 °C +68 °F		2152	4838	2521	5667	53,0	3.23	1,15	2.54	✓
RF 1500 - 016 - A	16	0.63	86	3.39	70	2.76			2213	4975	2616	5881	61,0	3.72	1,18	2.60	✓
RF 1500 - 019 - A	19	0.75	92	3.62	73	2.87			2262	5085	2693	6054	69,0	4.21	1,22	2.69	✓
RF 1500 - 025 - A	25	0.98	104	4.09	79	3.11			2336	5252	2811	6319	85,0	5.19	1,29	2.84	✓
RF 1500 - 032 - A	32	1.26	118	4.65	86	3.39			2397	5389	2908	6537	103,0	6.28	1,37	3.02	✓
RF 1500 - 038 - A	38	1.50	130	5.12	92	3.62			2435	5475	2971	6679	119,0	7.26	1,44	3.17	✓
RF 1500 - 050 - A	50	1.97	154	6.06	104	4.09			2490	5597	3059	6877	151,0	9.21	1,58	3.48	✓
RF 1500 - 063 - A	63	2.48	180	7.09	117	4.61			2529	5685	3123	7021	186,0	11.35	1,74	3.84	✓
RF 1500 - 075 - A	75	2.95	204	8.03	129	5.08			2555	5743	3165	7115	217,0	13.24	1,88	4.14	✓
RF 1500 - 080 - A	80	3.15	214	8.43	134	5.28			2563	5763	3180	7149	231,0	14.09	1,94	4.28	✓
RF 1500 - 100 - A	100	3.94	254	10.00	154	6.06			2590	5824	3224	7248	284,0	17.32	2,18	4.81	✓
RF 1500 - 125 - A	125	4.92	304	11.97	179	7.05			2613	5875	3262	7333	350,0	21.35	2,47	5.45	✓

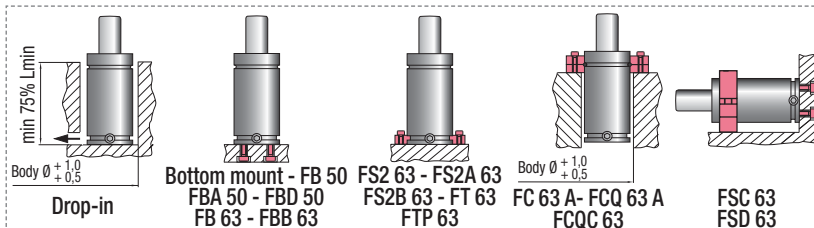

HOW TO ORDER

(10 pcs) RF 1500-050-A
 (10 pcs) RF 1500-050-A-N

OSAS + OSM = OVER STROKE ACTIVE SAFETY + OVER STROKE MARKER

ACTIVE SAFETY



p. 211



OSAS



USAS



OPAS

* $F_{1i} =$

Isothermal end force at 100% Cu

p. 16

** $F_{1p} =$

Polytropic end force at 100% Cu

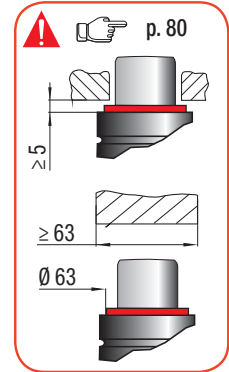
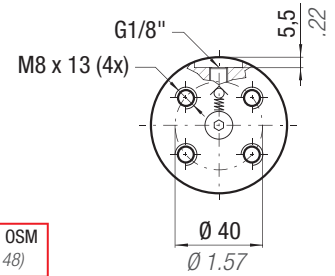
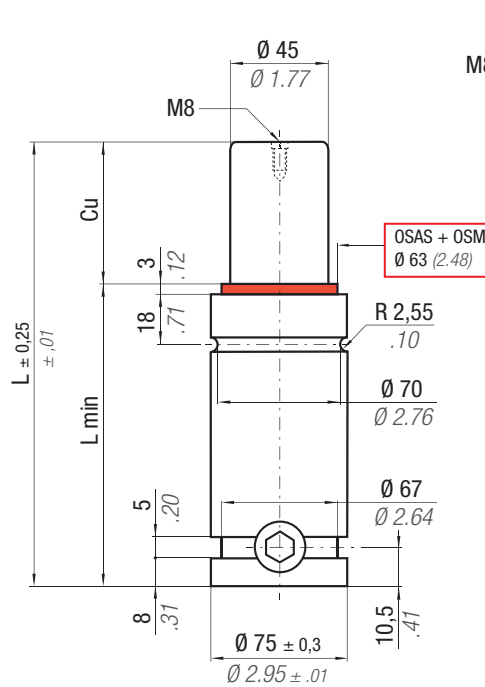

	°F 32 - 176	°C 0 - 80	ΔP ± 0,33 %/°C	P max 150 bar 2175 psi	P min 20 bar 290 psi	S 15,90 cm ² 2,465 in ²	SPM ~ 20 - 100 (at 20°C)	Max Speed 1,8 m/s	Maintenance kit 39BMRV02400C
--	----------------------	--------------------	---------------------------	------------------------------	----------------------------	---	--------------------------------	----------------------	---------------------------------

CODE	Cu		L		L min		F ₀		F _{1i} *		F _{1p} **		V ₀		PED		
	mm	inch	mm	inch	mm	inch	daN	lb	daN	lb	daN	lb	cm ³	in ³	~Kg	~lb	2014/68/EU
RF 2400 - 016 - A	16	0.63	87	3.43	71	2.80	2385 ± 5%	5362	3493	7852	4142	9312	93,0	5.67	1,68	3.70	✓
RF 2400 - 019 - A	19	0.75	93	3.66	74	2.91			3574	8035	4271	9602	105,0	6.41	1,73	3.81	✓
RF 2400 - 025 - A	25	0.98	105	4.13	80	3.15			3698	8313	4468	10044	129,0	7.87	1,82	4.01	✓
RF 2400 - 032 - A	32	1.26	119	4.69	87	3.43			3800	8542	4632	10413	157,0	9.58	1,93	4.25	✓
RF 2400 - 038 - A	38	1.50	131	5.16	93	3.66			3864	8687	4737	10649	181,0	11.04	2,03	4.48	✓
RF 2400 - 050 - A	50	1.97	155	6.10	105	4.13			3956	8893	4887	10986	230,0	14.03	2,21	4.87	✓
RF 2400 - 063 - A	63	2.48	181	7.13	118	4.65			4022	9042	4996	11231	282,0	17.20	2,42	5.34	✓
RF 2400 - 075 - A	75	2.95	205	8.07	130	5.12			4066	9140	5068	11393	330,0	20.13	2,61	5.75	✓
RF 2400 - 080 - A	80	3.15	215	8.46	135	5.31			4081	9174	5093	11450	350,0	21.35	2,69	5.93	✓
RF 2400 - 100 - A	100	3.94	255	10.04	155	6.10			4127	9278	5169	11620	431,0	26.29	3,00	6.61	✓
RF 2400 - 125 - A	125	4.92	305	12.01	180	7.09	4166	9365	5234	11767	532,0	32.45	3,40	7.50	✓		

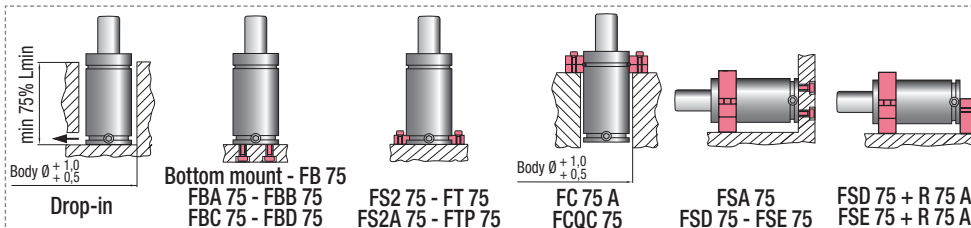

HOW TO ORDER

(10 pcs) RF 2400-050-A
(10 pcs) RF 2400-050-A-N



THIS PAGE IS INTENTIONALLY LEFT BLANK



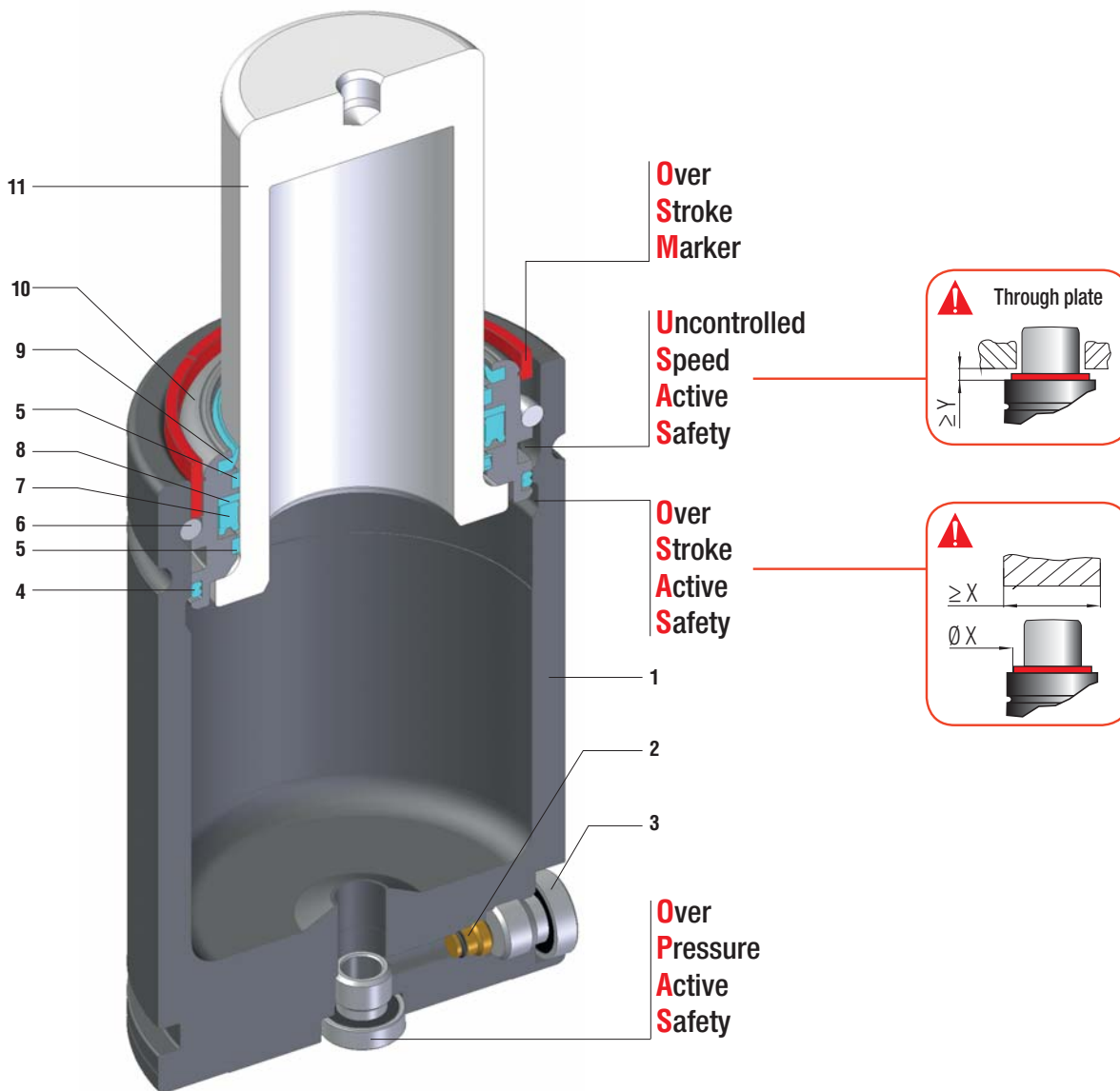





Minima altezza, massima forza, collegabili G1/8 - Minimum height, maximum force, hose cylinders with G1/8 charging port - Minimale Höhe, maximale Kraft, Gdf. mit G1/8 Öffnung verbindbar - Hauteur minimale, force maximale, cylindres raccordés avec trou G1/8 gaz - Mínima altura, máxima fuerza, cilindros conectados con agujero G1/8 gas - Altura mínima, força máxima, cilindros conectados com furo G1/8 gás

SEALING	ROD SEAL
DESIGN	BUSH - BODY DESIGN

1	Body	5	Guide ring	9	Rod wiper
2	Valve	6	Retaining ring	10	Bush
3	Plug	7	Rod seal	11	Rod (nitrited superfinished)
4	Dual ring seal	8	Back-up ring		

RANGE CHART

Model	Body Ø		Stroke Cu		Initial force F0					
	mm	inch	mm	inch	daN	lb	OSAS	USAS	OPAS	SKUDO
RG 750	45	1.77	10 - 125	0.39 - 4.92	740	1664	✓	✓	✓	-
RG 1000	50	1.97	10 - 125	0.39 - 4.92	920	2068	✓	✓	✓	-
RG 1500	63	2.48	10 - 125	0.39 - 4.92	1530	3440	✓	✓	✓	-
RG 2400	75	2.95	10 - 125	0.39 - 4.92	2385	5362	✓	✓	✓	-
RG 4200	95	3.74	16 - 125	0.63 - 4.92	4240	9532	✓	✓	✓	-
RG 6600	120	4.72	16 - 125	0.63 - 4.92	6630	14905	✓	✓	✓	-

RG



HOW TO ORDER



RG 2400-050-A - N - E

IT Codice cilindro autonomo
EN Self-contained cylinder code
DE Kode des eingeständigen Gdf.
FR Code du cylindre autonome
ES Código del cilindro autónomo
PT Código do cilindro autónomo

IT Collegabile con tubi, cilindro fornito scarico e senza valvola unidirezionale
EN Linkable with hoses, cylinder supplied without pressure and oneway valve
DE Anschlussfähig mit Leitungen, Gdf. geliefert ohne Druck und RückschlagVentil
FR Connectable avec tubes, ressort fourni sans pression ni valve unidirectionelle
ES Connectable con tubos, cilindro suministrado sin presión y sin válvula unidireccional
PT Acompláveis com tubos, cilindro fornecidos sem pressão e sem válvula unidireccional

IT Collegabile EASY MANIFOLD, fornito scarico + guarnizione di collegamento
EN Linkable EASY MANIFOLD, supplied without pressure + connecting seal
DE Anschlussfähig EASY MANIFOLD, geliefert ohne Druck + Verbindungsdichtung
FR Connectable EASY MANIFOLD, fourni sans pression + joint de connexion
ES Connectable EASY MANIFOLD, suministrado sin presión + junta de conexión
PT Acompláveis EASY MANIFOLD, fornecidos sem pressão + vedantes de conexão



OSAS + OSM = OVER STROKE ACTIVE SAFETY + OVER STROKE MARKER

ACTIVE SAFETY



OSAS



USAS



OPAS

* F_{1i} = Isothermal end force at 100% Cu p. 16 → ** F_{1p} = Polytrophic end force at 100% Cu

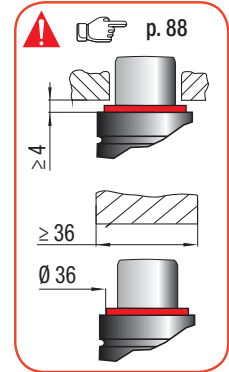
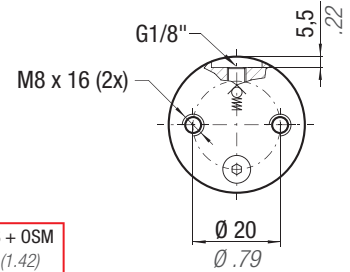
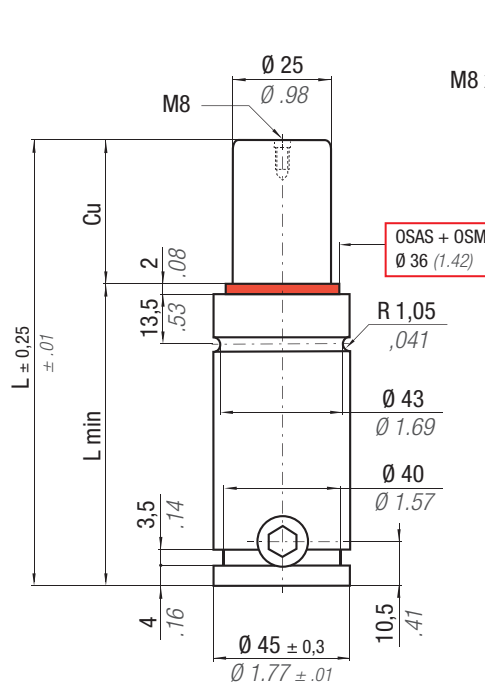

CODE	Cu		L		L min		F ₀		F _{1i} *		F _{1p} **		V ₀		Maintenance kit		
	mm	inch	mm	inch	mm	inch	daN	lb	daN	lb	daN	lb	cm ³	in ³	~Kg	~lb	
RG 750 - 010 - A	10	0.39	67	2.64	57	2.24	740 ± 5% 150 bar 2175psi + 20 °C +68 °F	1664	1018	2288	1184	2662	21,0	1.28	0,50	1.10	✓
RG 750 - 013 - A	13	0.51	73	2.87	60	2.36			1056	2373	1243	2795	24,0	1.46	0,52	1.15	✓
RG 750 - 016 - A	16	0.63	79	3.11	63	2.48			1085	2439	1289	2899	28,0	1.71	0,54	1.19	✓
RG 750 - 019 - A	19	0.75	85	3.35	66	2.60			1108	2492	1326	2982	32,0	1.95	0,56	1.23	✓
RG 750 - 025 - A	25	0.98	97	3.82	72	2.83			1143	2570	1382	3107	40,0	2.44	0,60	1.32	✓
RG 750 - 032 - A	32	1.26	111	4.37	79	3.11			1172	2634	1428	3210	49,0	2.99	0,64	1.41	✓
RG 750 - 038 - A	38	1.50	123	4.84	85	3.35			1189	2674	1457	3275	56,0	3.42	0,68	1.50	✓
RG 750 - 050 - A	50	1.97	147	5.79	97	3.82			1214	2730	1497	3366	72,0	4.39	0,76	1.68	✓
RG 750 - 063 - A	63	2.48	173	6.81	110	4.33			1232	2770	1527	3432	88,0	5.37	0,84	1.85	✓
RG 750 - 075 - A	75	2.95	197	7.76	122	4.80			1244	2796	1546	3475	103,0	6.28	0,92	2.03	✓
RG 750 - 080 - A	80	3.15	207	8.15	127	5.00			1248	2805	1552	3490	110,0	6.71	0,95	2.09	✓
RG 750 - 100 - A	100	3.94	247	9.72	147	5.79			1260	2832	1573	3535	135,0	8.24	1,08	2.38	✓
RG 750 - 125 - A	125	4.92	297	11.69	172	6.77			1270	2855	1589	3573	167,0	10.19	1,24	2.73	✓

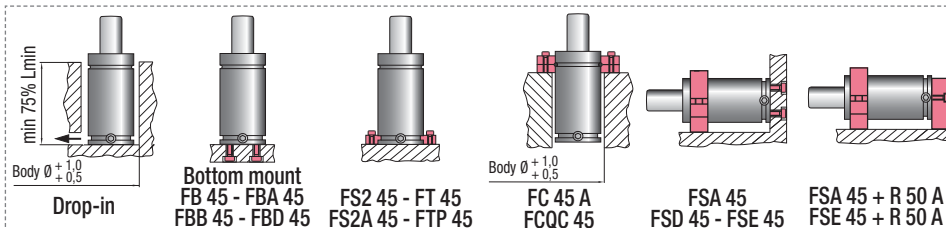

HOW TO ORDER

(10 pcs) RG 750-050-A
(10 pcs) RG 750-050-A-N

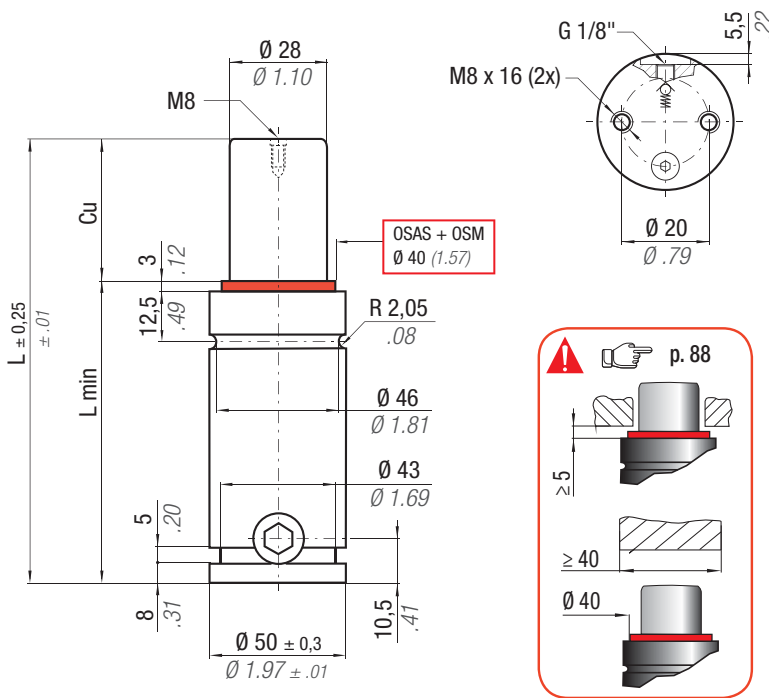

OSAS + OSM = OVER STROKE ACTIVE SAFETY + OVER STROKE MARKER

* F_{1i} = Isothermal end force at 100% Cu p. 16
 ** F_{1p} = Polythropic end force at 100% Cu



ACTIVE SAFETY



OSAS



USAS



OPAS

RG

CODE	Cu		L		L min		F ₀		F _{1i} *		F _{1p} **		V ₀		Maintenance kit		
	mm	inch	mm	inch	mm	inch	daN	lb	daN	lb	daN	lb	cm ³	in ³	~Kg	~lb	
RG 1000 - 010 - A	10	0.39	72	2.83	62	2.44	920 ± 5%	2068	1274	2863	1481	3329	26,0	1.59	0,67	1,48	✓
RG 1000 - 013 - A	13	0.51	78	3.07	65	2.56			1323	2973	1557	3500	31,0	1.89	0,70	1,54	✓
RG 1000 - 016 - A	16	0.63	84	3.31	68	2.68			1361	3059	1617	3635	35,0	2.14	0,72	1,59	✓
RG 1000 - 019 - A	19	0.75	90	3.54	71	2.80			1391	3128	1666	3745	40,0	2.44	0,75	1,65	✓
RG 1000 - 025 - A	25	0.98	102	4.02	77	3.03			1437	3232	1739	3909	50,0	3.05	0,79	1,74	✓
RG 1000 - 032 - A	32	1.26	116	4.57	84	3.31			1475	3316	1800	4047	61,0	3.72	0,85	1,87	✓
RG 1000 - 038 - A	38	1.50	128	5.04	90	3.54			1499	3369	1838	4132	70,0	4.27	0,90	1,98	✓
RG 1000 - 050 - A	50	1.97	152	5.98	102	4.02			1532	3445	1893	4256	89,0	5.43	0,99	2,18	✓
RG 1000 - 063 - A	63	2.48	178	7.01	115	4.53			1556	3499	1933	4346	109,0	6.65	1,10	2,43	✓
RG 1000 - 075 - A	75	2.95	202	7.95	127	5.00			1572	3534	1959	4404	128,0	7.81	1,19	2,62	✓
RG 1000 - 080 - A	80	3.15	212	8.35	132	5.20	1578	3546	1968	4424	136,0	8.30	1,23	2,71	✓		
RG 1000 - 100 - A	100	3.94	252	9.92	152	5.98	1594	3584	1995	4485	167,0	10.19	1,39	3,06	✓		
RG 1000 - 125 - A	125	4.92	302	11.89	177	6.97	1608	3615	2018	4537	207,0	12.63	1,60	3,53	✓		

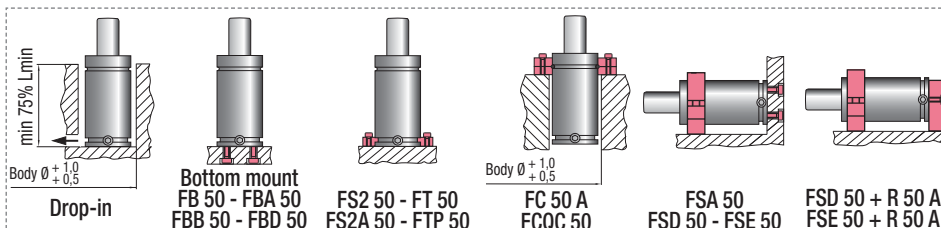

HOW TO ORDER

(10 pcs) RG 1000-050-A
 (10 pcs) RG 1000-050-A-N



OSAS + OSM = OVER STROKE ACTIVE SAFETY + OVER STROKE MARKER

ACTIVE SAFETY

* F_{1i} = Isothermal end force at 100% Cu p. 16 ** F_{1p} = Polytrophic end force at 100% Cu



OSAS



USAS



OPAS

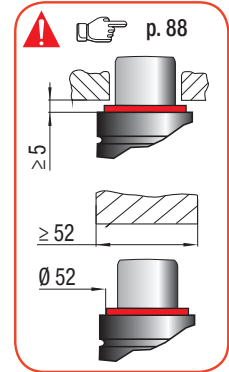
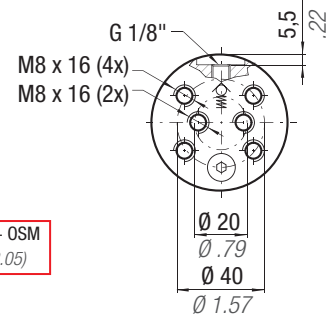
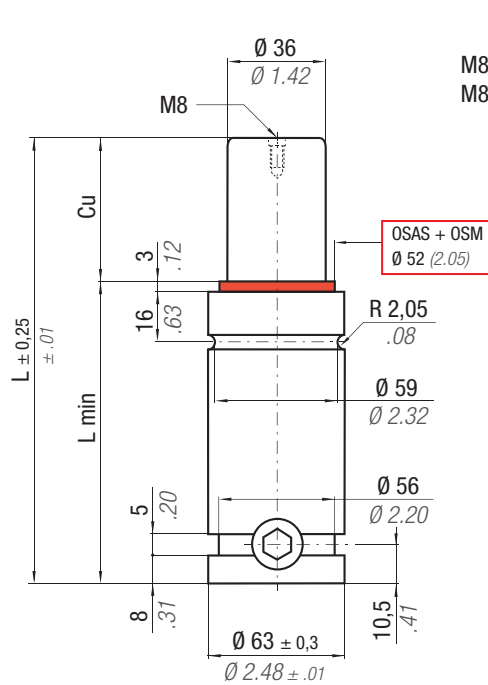

CODE	N ₂	°F 32 - 176	°C 0 - 80	ΔP ± 0,33 %/°C	P max 150 bar 2175 psi	P min 20 bar 290 psi	S 10,18 cm ² 1.578 in ²	SPM ~ 20 - 100 (at 20°C)	Max Speed 1,8 m/s	Maintenance kit 39BMRV01500C	Vo		PED		
											cm ³	in ³	~Kg	~lb	2014/68/EU
RG 1500 - 010 - A											45,0	2,75	1,04	2,29	✓
RG 1500 - 013 - A											53,0	3,23	1,08	2,38	✓
RG 1500 - 016 - A											61,0	3,72	1,11	2,45	✓
RG 1500 - 019 - A											69,0	4,21	1,15	2,54	✓
RG 1500 - 025 - A											85,0	5,19	1,22	2,69	✓
RG 1500 - 032 - A											104,0	6,34	1,30	2,87	✓
RG 1500 - 038 - A											119,0	7,26	1,37	3,02	✓
RG 1500 - 050 - A											151,0	9,21	1,51	3,33	✓
RG 1500 - 063 - A											186,0	11,35	1,67	3,68	✓
RG 1500 - 075 - A											218,0	13,30	1,81	3,99	✓
RG 1500 - 080 - A											231,0	14,09	1,87	4,12	✓
RG 1500 - 100 - A											284,0	17,32	2,11	4,65	✓
RG 1500 - 125 - A											350,0	21,35	2,40	5,29	✓

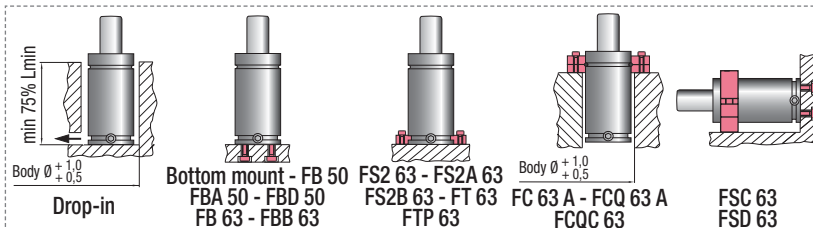

HOW TO ORDER

(10 pcs) RG 1500-050-A
(10 pcs) RG 1500-050-A-N

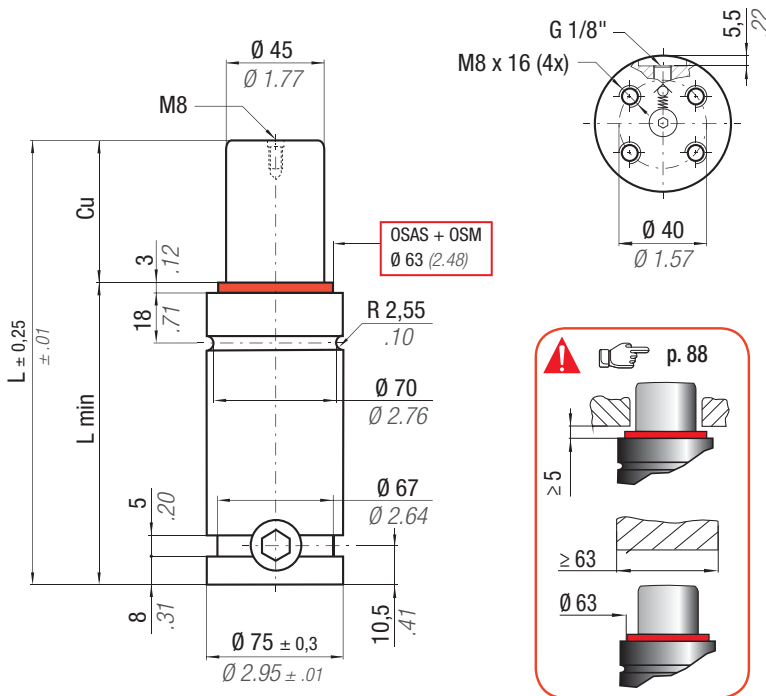

OSAS + OSM = OVER STROKE ACTIVE SAFETY + OVER STROKE MARKER



easu MANIFOLD READY p. 211

ACTIVE SAFETY

* F_{1i} =

Isothermal end force at 100% Cu

p. 16

** F_{1p} =

Polytropic end force at 100% Cu



OSAS



USAS



OPAS

RG

	$^{\circ}\text{F}$ 32 - 176	$^{\circ}\text{C}$ 0 - 80	ΔP $\pm 0,33\% / ^{\circ}\text{C}$	P max 150 bar 2175 psi	P min 20 bar 290 psi	S 15,90 cm ² 2.465 in ²	SPM ~ 20 - 100 (at 20°C)	Max Speed 1,8 m/s	Maintenance kit 39BMRV02400C								
CODE	Cu		L		L min		F₀ Initial force		F_{1i} * End force		F_{1p} ** End force		V₀				
	mm	inch	mm	inch	mm	inch	daN	lb	daN	lb	daN	lb	cm ³	in ³	~Kg	~lb	2014/68/EU
RG 2400 - 010 - A	10	0.39	79	3.11	69	2.72	2385 ± 5% 5362	150 bar 2175 psi	3125	7026	3574	8035	78,0	4.76	1,65	3.64	✓
RG 2400 - 013 - A	13	0.51	85	3.35	72	2.83			3249	7305	3763	8460	90,0	5.49	1,70	3.75	✓
RG 2400 - 016 - A	16	0.63	91	3.58	75	2.95			3350	7532	3920	8813	103,0	6.28	1,75	3.86	✓
RG 2400 - 019 - A	19	0.75	97	3.82	78	3.07			3434	7721	4051	9107	115,0	7.02	1,79	3.95	✓
RG 2400 - 025 - A	25	0.98	109	4.29	84	3.31			3566	8016	4258	9572	139,0	8.48	1,89	4.17	✓
RG 2400 - 032 - A	32	1.26	123	4.84	91	3.58			3678	8268	4436	9973	167,0	10.19	1,99	4.39	✓
RG 2400 - 038 - A	38	1.50	135	5.31	97	3.82			3751	8433	4554	10238	191,0	11.65	2,09	4.61	✓
RG 2400 - 050 - A	50	1.97	159	6.26	109	4.29			3858	8672	4726	10624	239,0	14.58	2,28	5.03	✓
RG 2400 - 063 - A	63	2.48	185	7.28	122	4.80			3937	8850	4855	10914	292,0	17.81	2,49	5.49	✓
RG 2400 - 075 - A	75	2.95	209	8.23	134	5.28			3989	8969	4942	11110	340,0	20.74	2,68	5.91	✓
RG 2400 - 080 - A	80	3.15	219	8.62	139	5.47	4008	9010	4972	11178	360,1	21.97	2,75	6.06	✓		
RG 2400 - 100 - A	100	3.94	259	10.20	159	6.26	4065	9138	5066	11389	441,0	26.90	3,07	6.77	✓		
RG 2400 - 125 - A	125	4.92	309	12.17	184	7.24	4113	9247	5147	11571	541,0	33.00	3,46	7.63	✓		

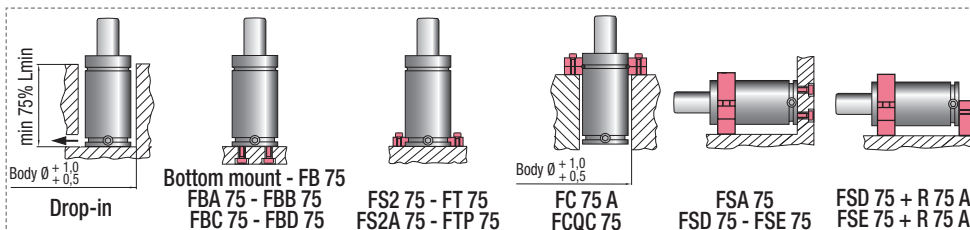

HOW TO ORDER

(10 pcs) RG2400-050-A
(10 pcs) RG 2400-050-A-N



OSAS + OSM = OVER STROKE ACTIVE SAFETY + OVER STROKE MARKER

ACTIVE SAFETY

easyl MANIFOLD p. 211



OSAS

* F_{1i} = Isothermal end force at 100% Cu p. 16

** F_{1p} = Polytropic end force at 100% Cu p. 16



USAS



OPAS

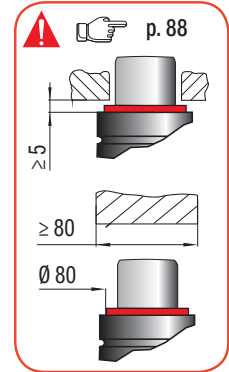
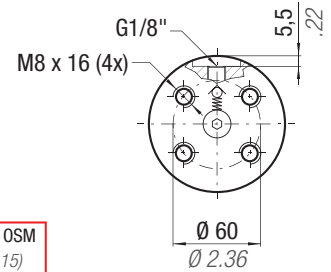
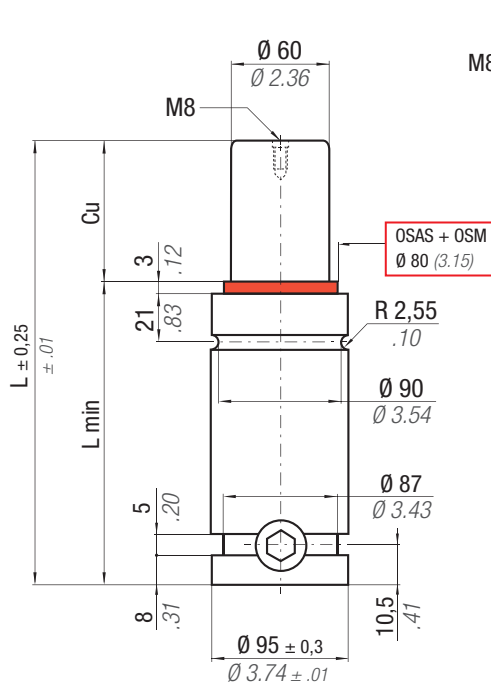

CODE	N ₂	°F 32 - 176	°C 0 - 80	ΔP ± 0,33 %/°C	P max 150 bar 2175 psi	P min 20 bar 290 psi	S 28,27 cm ² 4,382 in ²	SPM ~ 20 - 100 (at 20°C)	Max Speed 1,8 m/s	Maintenance kit 39BMRV04200C	Vo		PED		
											mm	inch	~Kg	~lb	2014/68/EU
RG 4200 - 016 - A											16	0.63	2,98	6,57	✓
RG 4200 - 019 - A											19	0.75	3,05	6,72	✓
RG 4200 - 025 - A											25	0.98	3,20	7,05	✓
RG 4200 - 032 - A											32	1.26	3,38	7,45	✓
RG 4200 - 038 - A											38	1.50	3,52	7,76	✓
RG 4200 - 050 - A											50	1.97	3,82	8,42	✓
RG 4200 - 063 - A											63	2.48	4,15	9,15	✓
RG 4200 - 075 - A											75	2.95	4,45	9,81	✓
RG 4200 - 080 - A											80	3.15	4,57	10,08	✓
RG 4200 - 100 - A											100	3.94	5,07	11,18	✓
RG 4200 - 125 - A											125	4.92	5,69	12,54	✓

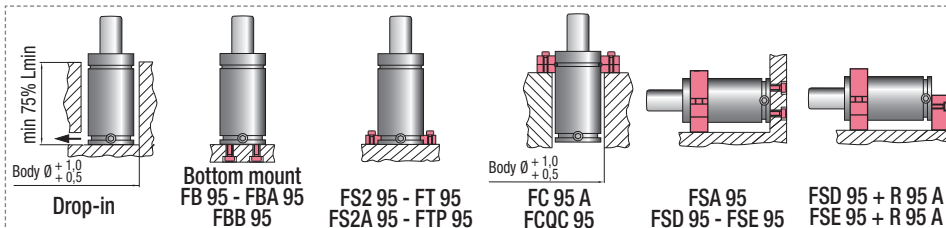

HOW TO ORDER

(10 pcs) RG 4200-050-A
(10 pcs) RG 4200-050-A-N

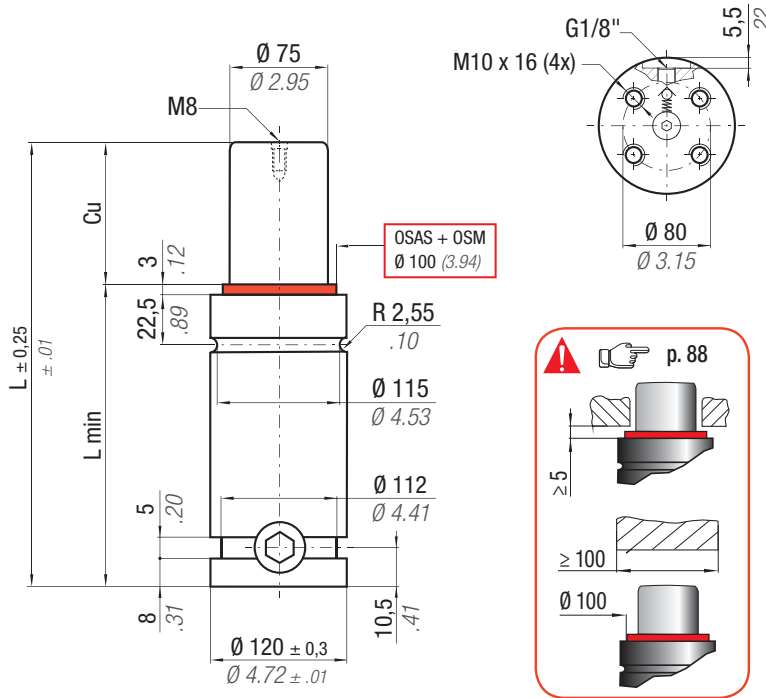

OSAS + OSM = OVER STROKE ACTIVE SAFETY + OVER STROKE MARKER



easu MANIFOLD p. 211

ACTIVE SAFETY

* F_{1i} =

Isothermal end force at 100% Cu p. 16

** F_{1p} =

Polytrophic end force at 100% Cu



OSAS



USAS



OPAS

RG

	$^{\circ}\text{F}$ 32 176	$^{\circ}\text{C}$ 0 80	ΔP $\pm 0,33\% / ^{\circ}\text{C}$	P max 150 bar 2175 psi	P min 20 bar 290 psi	S 44,18 cm ² 6.848 in ²	SPM ~ 20 - 100 (at 20°C)	Max Speed 1,8 m/s	Maintenance kit 39BMRV06600C
--	---------------------------------	-------------------------------	---	-------------------------------------	-----------------------------------	--	---------------------------------------	-----------------------------	--

CODE	Cu		L		L min		F ₀ Initial force		F _{1i} * End force		F _{1p} ** End force		V ₀		PED 2014/68/EU		
	mm	inch	mm	inch	mm	inch	daN	lb	daN	lb	daN	lb	cm ³	in ³	~Kg	~lb	
RG 6600 - 016 - A	16	0.63	104	4.09	88	3.46	6630 ± 5%	14904	9032	20306	10464	23524	309,0	18.85	5,40	11.90	✓
RG 6600 - 019 - A	19	0.75	110	4.33	91	3.58			9281	20864	10847	24385	341,0	20.80	5,52	12.17	✓
RG 6600 - 025 - A	25	0.98	122	4.80	97	3.82			9684	21771	11478	25804	405,0	24.71	5,76	12.70	✓
RG 6600 - 032 - A	32	1.26	136	5.35	104	4.09			10044	22579	12047	27083	479,0	29.22	6,04	13.32	✓
RG 6600 - 038 - A	38	1.50	148	5.83	110	4.33			10286	23124	12435	27955	544,0	33.18	6,28	13.85	✓
RG 6600 - 050 - A	50	1.97	172	6.77	122	4.80			10652	23946	13025	29281	672,0	40.99	6,76	14.90	✓
RG 6600 - 063 - A	63	2.48	198	7.80	135	5.31			10932	24577	13483	30311	811,0	49.47	7,28	16.05	✓
RG 6600 - 075 - A	75	2.95	222	8.74	147	5.79			11125	25011	13800	31024	939,0	57.28	7,75	17.09	✓
RG 6600 - 080 - A	80	3.15	232	9.13	152	5.98			11193	25162	13910	31271	992,0	60.51	7,95	17.53	✓
RG 6600 - 100 - A	100	3.94	272	10.71	172	6.77			11407	25643	14264	32067	1206,0	73.57	8,75	19.29	✓
RG 6600 - 125 - A	125	4.92	322	12.68	197	7.76	11593	26061	14574	32764	1473,0	89.85	9,75	21.50	✓		

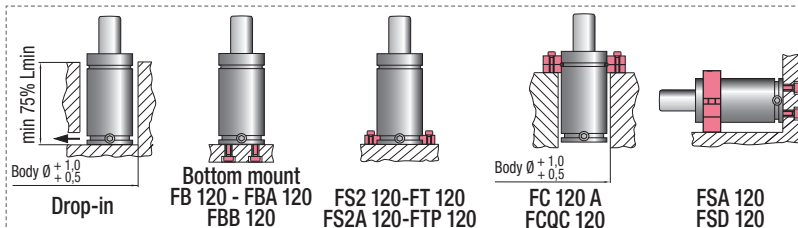

HOW TO ORDER

(10 pcs) RG 6600-050-A
(10 pcs) RG 6600-050-A-N

Mazda	Nissan	PSA
Toyota		

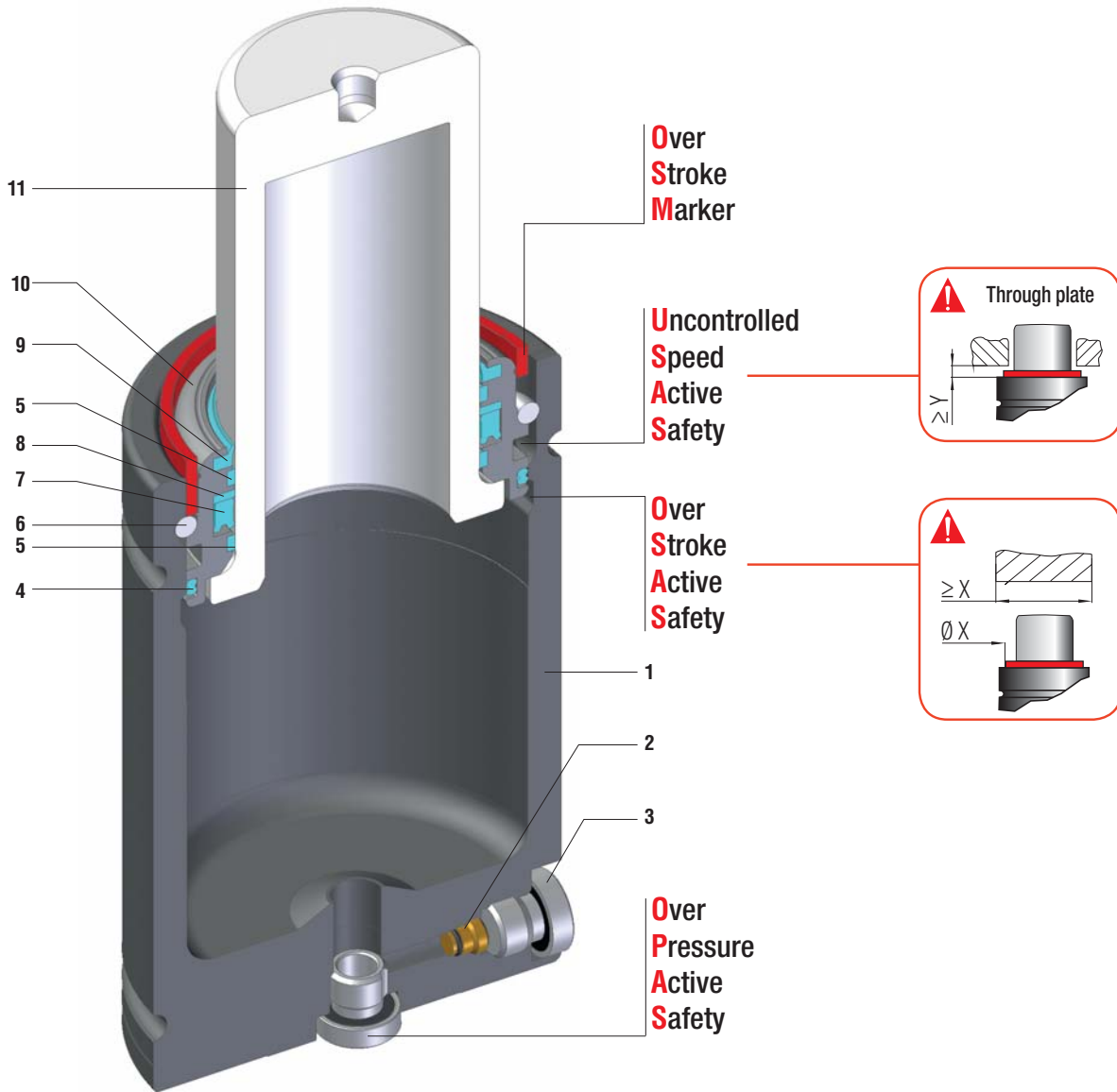

Minima altezza, massima forza, collegabili G1/8 - Minimum height, maximum force, hose cylinders with G1/8 charging port
 Minimale Höhe, maximale Kraft, Gdf. mit G1/8 Öffnung verbindbar - Hauteur minimale, force maximale, cylindres raccordés avec trou G1/8 gaz
 Mínima altura, máxima fuerza, cilindros conectados con agujero G1/8 gas - Altura mínima, força máxima, cilindros conectados com furo G1/8 gás

SEALING	ROD SEAL
DESIGN	BUSH - BODY DESIGN

1	Body	5	Guide ring	9	Rod wiper
2	Valve	6	Retaining ring	10	Bush
3	Plug	7	Rod seal	11	Rod (nitrited superfinished)
4	Dual ring seal	8	Back-up ring		

RANGE CHART

Model	Body Ø		Stroke Cu		Initial force F0					
	mm	inch	mm	inch	daN	lb				
RT 350	32	1.26	10 - 125	0.39 - 4.92	360	809	✓	✓	✓	-
RT 500	38	1.50	10 - 125	0.39 - 4.92	470	1057	✓	✓	✓	-
RT 750	45	1.77	10 - 125	0.39 - 4.92	740	1664	✓	✓	✓	-
RT 1000	50	1.97	10 - 125	0.39 - 4.92	920	2068	✓	✓	✓	-
RT 1200	50	1.97	10 - 125	0.39 - 4.92	1060	2383	✓	✓	✓	-
RT 1500	63	2.48	10 - 125	0.39 - 4.92	1530	3440	✓	✓	✓	-
RT 2400	75	2.95	10 - 125	0.39 - 4.92	2385	5362	✓	✓	✓	-
RT 4200	95	3.74	16 - 125	0.63 - 4.92	4240	9532	✓	✓	✓	-
RT 6600	120	4.72	16 - 125	0.63 - 4.92	6630	14905	✓	✓	✓	-
RT 9500	150	5.91	19 - 125	0.75 - 4.92	9540	21447	✓	✓	✓	-

RT

HOW TO ORDER

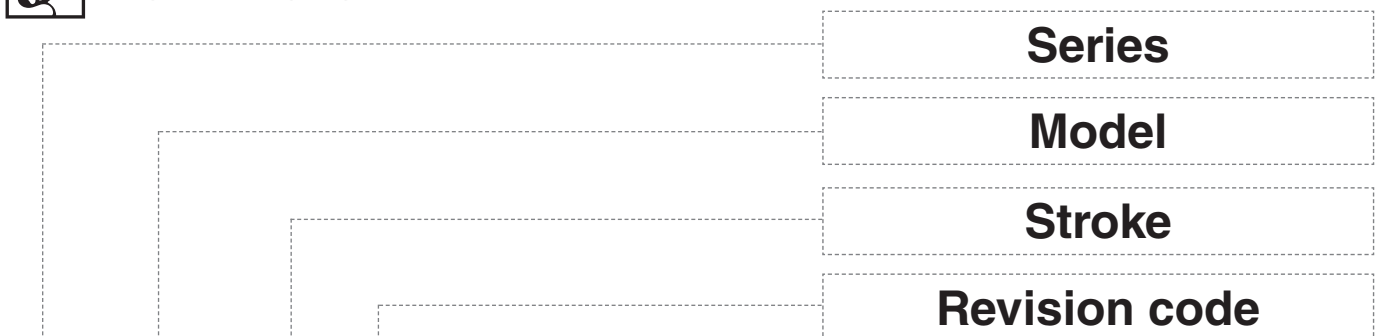

RT 2400-050-A - N - E

- IT** Codice cilindro autonomo
- EN** Self-contained cylinder code
- DE** Kode des eingeständigen Gdf.
- FR** Code du cylindre autonome
- ES** Código del cilindro autónomo
- PT** Código do cilindro autónomo

- IT** Collegabile con tubi, cilindro fornito scarico e senza valvola unidirezionale
- EN** Linkable with hoses, cylinder supplied without pressure and oneway valve
- DE** Anschlussfähig mit Leitungen, Gdf. geliefert ohne Druck und RückschlagVentil
- FR** Connectable avec tubes, ressort fourni sans pression ni valve unidirectionelle
- ES** Connectable con tubos, cilindro suministrado sin presión y sin válvula unidireccional
- PT** Acompláveis com tubos, cilindro fornecidos sem pressão e sem válvula unidireccional

- IT** Collegabile EASY MANIFOLD, fornito scarico + guarnizione di collegamento
- EN** Linkable EASY MANIFOLD, supplied without pressure + connecting seal
- DE** Anschlussfähig EASY MANIFOLD, geliefert ohne Druck + Verbindungsdichtung
- FR** Connectable EASY MANIFOLD, fourni sans pression + joint de connexion
- ES** Connectable EASY MANIFOLD, suministrado sin presión + junta de conexión
- PT** Acompláveis EASY MANIFOLD, fornecidos sem pressão + vedantes de conexão



OSAS + OSM = **OVER STROKE ACTIVE SAFETY** + **OVER STROKE MARKER**

ACTIVE SAFETY

* F_{1i} = Isothermal end force at 100% Cu p. 16
 ** F_{1p} = Polytrophic end force at 100% Cu



OSAS



USAS



OPAS

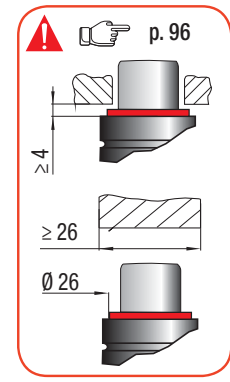
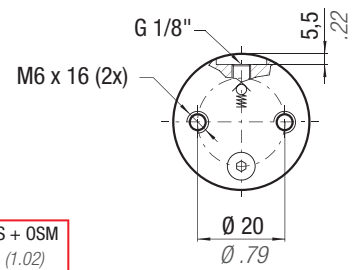
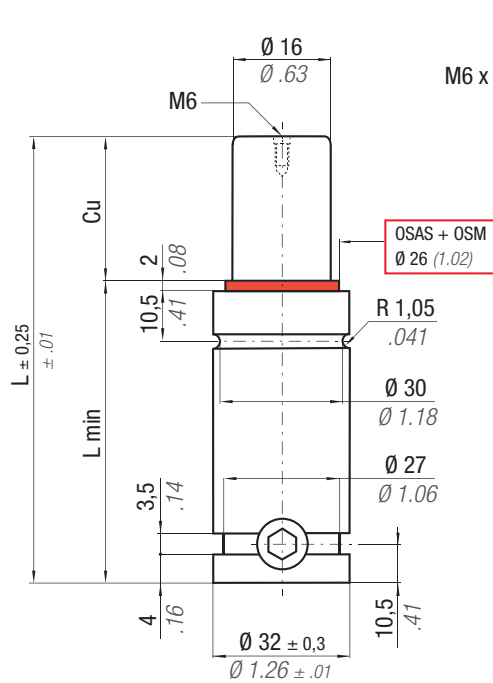

	$^{\circ}\text{F}$ 32 - 176	$^{\circ}\text{C}$ 0 - 80	ΔP ± 0,33 %/°C	P max 180 bar 2610 psi	P min 20 bar 290 psi	S 2,01 cm ² 0,312 in ²	SPM ~ 20 - 100 (at 20°C)	Max Speed 1,8 m/s	Maintenance kit 39BMRV00350C
--	--------------------------------------	------------------------------------	---------------------------------	-------------------------------------	-----------------------------------	---	---------------------------------------	-----------------------------	--

CODE	Cu		L		L min		F ₀		F _{1i} *		F _{1p} **		V ₀		PED		
	mm	inch	mm	inch	mm	inch	daN	lb	daN	lb	daN	lb	cm ³	in ³	~Kg	~lb	2014/68/EU
RT 350 - 010 - A	10	0.39	60	2.36	50	1.97	360 809 ± 5%		523	1176	596	1340	8,0	0.49	0,22	0.48	✓
RT 350 - 013 - A	13	0.51	66	2.60	53	2.09			536	1206	615	1384	10,0	0.61	0,23	0.50	✓
RT 350 - 016 - A	16	0.63	72	2.83	56	2.20			546	1228	629	1415	12,0	0.73	0,24	0.52	✓
RT 350 - 019 - A	19	0.75	78	3.07	59	2.32			553	1244	640	1439	13,0	0.79	0,25	0.54	✓
RT 350 - 025 - A	25	0.98	90	3.54	65	2.56			564	1267	655	1472	17,0	1.04	0,27	0.60	✓
RT 350 - 032 - A	32	1.26	104	4.09	72	2.83			571	1285	666	1497	21,0	1.28	0,29	0.64	✓
RT 350 - 038 - A	38	1.50	116	4.57	78	3.07			576	1295	673	1513	25,0	1.53	0,31	0.68	✓
RT 350 - 050 - A	50	1.97	140	5.51	90	3.54			582	1309	682	1533	32,0	1.95	0,35	0.77	✓
RT 350 - 063 - A	63	2.48	166	6.54	103	4.06			587	1319	688	1547	40,0	2.44	0,39	0.86	✓
RT 350 - 075 - A	75	2.95	190	7.48	115	4.53			589	1325	692	1556	47,0	2.87	0,43	0.95	✓
RT 350 - 080 - A	80	3.15	200	7.87	120	4.72	590	1327	693	1559	50,0	3.05	0,45	0.99	✓		
RT 350 - 100 - A	100	3.94	240	9.45	140	5.51	593	1333	698	1568	62,0	3.79	0,51	1.12	✓		
RT 350 - 125 - A	125	4.92	290	11.42	165	6.50	595	1338	701	1576	77,0	4.71	0,59	1.30	✓		

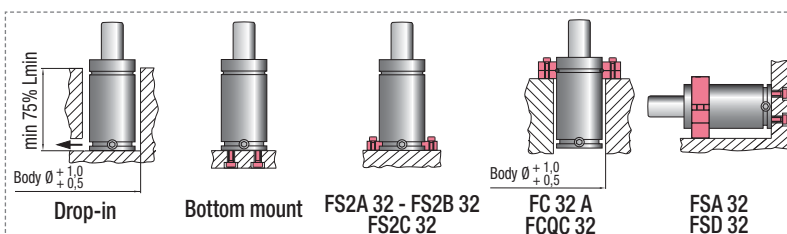

HOW TO ORDER
 (10 pcs) RT 350-050-A
 (10 pcs) RT 350-050-A-N

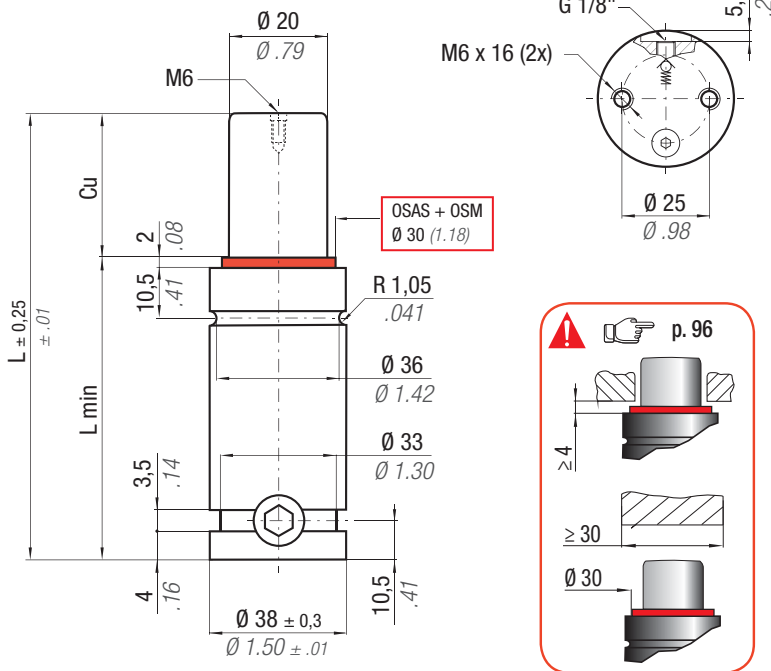

OSAS + OSM = OVER STROKE ACTIVE SAFETY + OVER STROKE MARKER

* F_{1i} = Isothermal end force at 100% Cu

** F_{1p} = Polythropic end force at 100% Cu



ACTIVE SAFETY



OSAS



USAS



OPAS

	°F 32 - 176	°C 0 - 80	ΔP ± 0,33 %/°C	P max 150 bar 2175 psi	P min 20 bar 290 psi	S 3,14 cm ² 0.487 in ²	SPM ~ 20 - 100 (at 20°C)	Max Speed 1,8 m/s	Maintenance kit 39BMRV00500C
--	----------------------	--------------------	---------------------------	-------------------------------------	-----------------------------------	---	---------------------------------------	-----------------------------	--

CODE	Cu		L		L min		F ₀ Initial force		F _{1i} * End force *		F _{1p} ** End force **		V ₀		PED 2014/68/EU		
	mm	inch	mm	inch	mm	inch	daN	lb	daN	lb	daN	lb	cm ³	in ³	~Kg	~lb	✓
RT 500 - 010 - A	10	0.39	60	2.36	50	1.97	470 ± 5%	1057	692	1555	821	1845	11,0	0.67	0,32	0.71	✓
RT 500 - 013 - A	13	0.51	66	2.60	53	2.09			711	1598	851	1914	14,0	0.85	0,34	0.75	✓
RT 500 - 016 - A	16	0.63	72	2.83	56	2.20			725	1629	873	1963	17,0	1.04	0,36	0.79	✓
RT 500 - 019 - A	19	0.75	78	3.07	59	2.32			735	1652	890	2001	19,0	1.16	0,37	0.82	✓
RT 500 - 025 - A	25	0.98	90	3.54	65	2.56			750	1685	914	2054	24,0	1.46	0,40	0.88	✓
RT 500 - 032 - A	32	1.26	104	4.09	72	2.83			761	1710	932	2094	30,0	1.83	0,43	0.95	✓
RT 500 - 038 - A	38	1.50	116	4.57	78	3.07			767	1725	942	2119	36,0	2.20	0,46	1.01	✓
RT 500 - 050 - A	50	1.97	140	5.51	90	3.54			776	1746	957	2152	46,0	2.81	0,52	1.15	✓
RT 500 - 063 - A	63	2.48	166	6.54	103	4.06			783	1759	967	2175	57,0	3.48	0,58	1.28	✓
RT 500 - 075 - A	75	2.95	190	7.48	115	4.53			787	1768	974	2189	67,0	4.09	0,63	1.39	✓
RT 500 - 080 - A	80	3.15	200	7.87	120	4.72	788	1771	976	2194	72,0	4.39	0,66	1.46	✓		
RT 500 - 100 - A	100	3.94	240	9.45	140	5.51	792	1780	983	2209	89,0	5.43	0,75	1.65	✓		
RT 500 - 125 - A	125	4.92	290	11.42	165	6.50	795	1788	988	2221	110,0	6.71	0,87	1.92	✓		

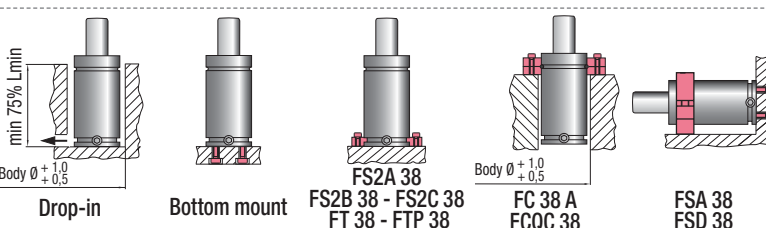

HOW TO ORDER

(10 pcs) RT 500-050-A
(10 pcs) RT 500-050-A-N

OSAS + OSM

 OVER STROKE
ACTIVE SAFETY + OVER
STROKE MARKER

ACTIVE SAFETY
 $* F_{1i} =$

 Isothermal
end force
at 100% Cu

p. 16

 $** F_{1p} =$

 Polytrophic
end force
at 100% Cu



OSAS



USAS

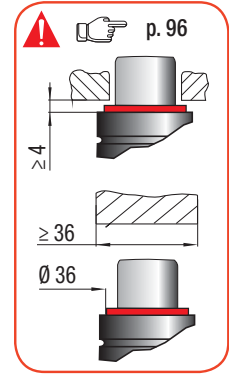
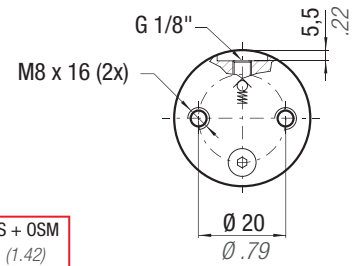
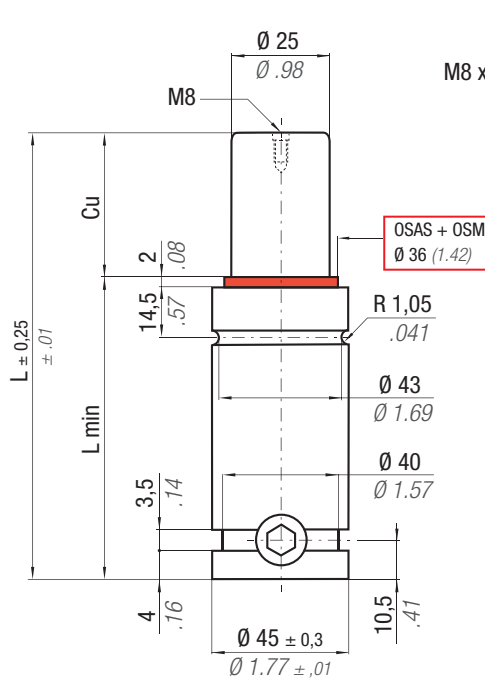

OPAS



	°F 32 - 176	°C 0 - 80	ΔP ± 0,33 %/°C	P max 150 bar 2175 psi	P min 20 bar 290 psi	S 4,91 cm ² 0,761 in ²	SPM ~ 20 - 100 (at 20°C)	Max Speed 1,8 m/s	Maintenance kit 39BMRV00750C
--	----------------------	--------------------	---------------------------	-------------------------------------	-----------------------------------	---	---------------------------------------	-----------------------------	--

CODE	Cu		L		L min		F ₀		F _{1i} *		F _{1p} **		V ₀		PED		
	mm	inch	mm	inch	mm	inch	daN	lb	daN	lb	daN	lb	cm ³	in ³	~Kg	~lb	2014/68/EU
RT 750 - 010 - A	10	0.39	67	2.64	57	2.24	740 ± 5%	1664	1018	2288	1184	2662	21,0	1.28	0,50	1.10	✓
RT 750 - 013 - A	13	0.51	73	2.87	60	2.36			1056	2373	1243	2794	24,0	1.46	0,52	1.15	✓
RT 750 - 016 - A	16	0.63	79	3.11	63	2.48			1085	2439	1289	2898	28,0	1.71	0,54	1.19	✓
RT 750 - 019 - A	19	0.75	85	3.35	66	2.60			1108	2492	1326	2981	32,0	1.95	0,56	1.23	✓
RT 750 - 025 - A	25	0.98	97	3.82	72	2.83			1143	2570	1382	3107	40,0	2.44	0,60	1.32	✓
RT 750 - 032 - A	32	1.26	111	4.37	79	3.11			1172	2634	1428	3210	49,0	2.99	0,64	1.41	✓
RT 750 - 038 - A	38	1.50	123	4.84	85	3.35			1189	2674	1457	3275	56,0	3.42	0,68	1.50	✓
RT 750 - 050 - A	50	1.97	147	5.79	97	3.82			1214	2730	1497	3365	72,0	4.39	0,76	1.68	✓
RT 750 - 063 - A	63	2.48	173	6.81	110	4.33			1232	2770	1527	3433	88,0	5.37	0,84	1.85	✓
RT 750 - 075 - A	75	2.95	197	7.76	122	4.80			1244	2796	1546	3476	103,0	6.28	0,92	2.03	✓
RT 750 - 080 - A	80	3.15	207	8.15	127	5.00	1248	2805	1552	3489	110,0	6.71	0,95	2.09	✓		
RT 750 - 100 - A	100	3.94	247	9.72	147	5.79	1260	2832	1573	3536	135,0	8.24	1,08	2.38	✓		
RT 750 - 125 - A	125	4.92	297	11.69	172	6.77	1270	2855	1589	3572	167,0	10.19	1,24	2.73	✓		

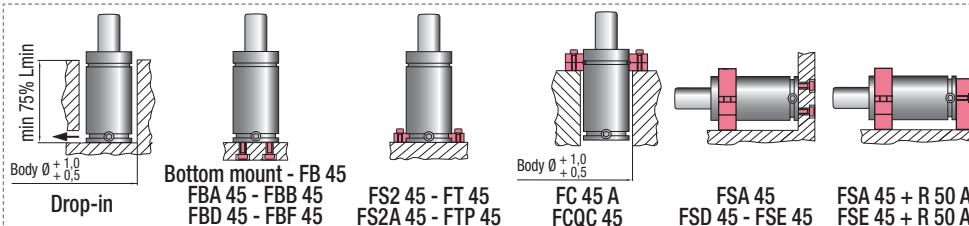
HOW TO ORDER

 (10 pcs) RT 750-050-A
 (10 pcs) RT 750-050-A-N

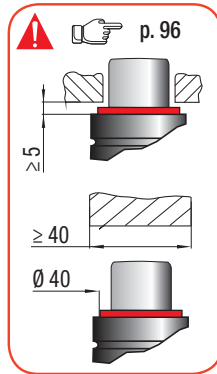
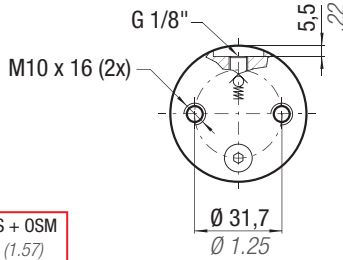
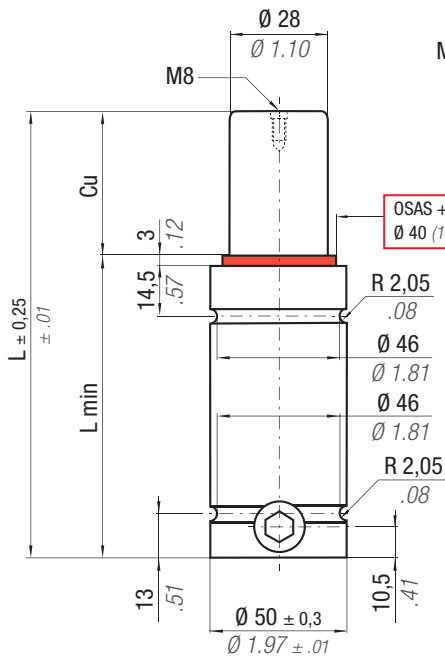

OSAS + OSM = OVER STROKE ACTIVE SAFETY + OVER STROKE MARKER

* F_{1i} = Isothermal end force at 100% Cu

** F_{1p} = Polytropic end force at 100% Cu

p. 16



ACTIVE SAFETY



OSAS



USAS



OPAS

CODE	Cu	L	L min	F ₀ Initial force	F _{1i} *		F _{1p} **		V ₀	Maintenance kit			
					daN	lb	daN	lb		~Kg	~lb		
RT 1000 - 010 - A	10	72	62	920 ± 5%	1274	2863	1481	3329	26,0	1,59	0,68	1,50	✓
RT 1000 - 013 - A	13	78	65		1323	2973	1557	3500	31,0	1,89	0,70	1,54	✓
RT 1000 - 016 - A	16	84	68		1361	3059	1617	3635	35,0	2,14	0,73	1,61	✓
RT 1000 - 019 - A	19	90	71		1391	3128	1666	3745	40,0	2,44	0,75	1,65	✓
RT 1000 - 025 - A	25	102	77		1437	3232	1739	3909	50,0	3,05	0,80	1,76	✓
RT 1000 - 032 - A	32	116	84		1475	3316	1800	4047	61,0	3,72	0,86	1,90	✓
RT 1000 - 038 - A	38	128	90		1499	3369	1838	4132	70,0	4,27	0,90	1,98	✓
RT 1000 - 050 - A	50	152	102		1532	3445	1893	4256	89,0	5,43	1,00	2,20	✓
RT 1000 - 063 - A	63	178	115		1556	3499	1933	4346	109,0	6,65	1,10	2,43	✓
RT 1000 - 075 - A	75	202	127		1572	3534	1959	4404	128,0	7,81	1,20	2,65	✓
RT 1000 - 080 - A	80	212	132	1578	3546	1968	4424	136,0	8,30	1,24	2,73	✓	
RT 1000 - 100 - A	100	252	152	1594	3584	1995	4485	167,0	10,19	1,40	3,09	✓	
RT 1000 - 125 - A	125	302	177	1608	3615	2018	4537	207,0	12,63	1,60	3,53	✓	

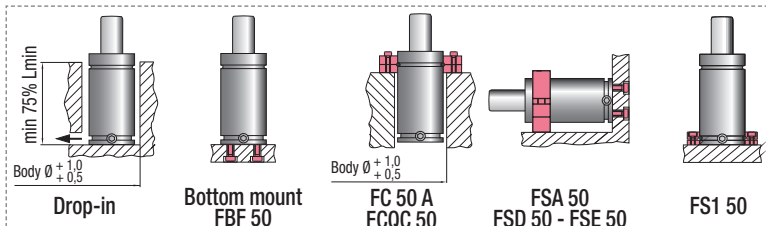

HOW TO ORDER

(10 pcs) RT 1000-050-A
(10 pcs) RT 1000-050-A-N



OSAS + OSM = OVER STROKE ACTIVE SAFETY + OVER STROKE MARKER

ACTIVE SAFETY

* F_{1i} = Isothermal end force at 100% Cu p. 16 ** F_{1p} = Polytrophic end force at 100% Cu



OSAS



USAS



OPAS

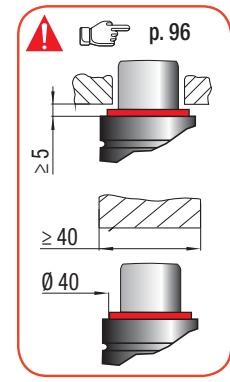
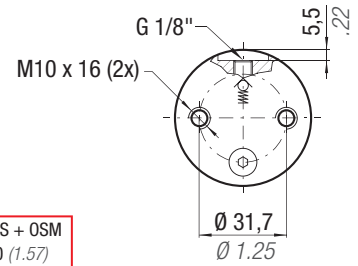
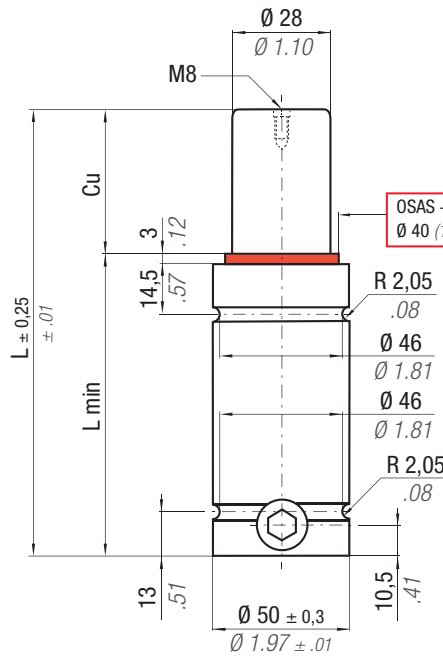

CODE	N ₂	°F 32 - 176	°C 0 - 80	ΔP ± 0,33 %/°C	P max 170 bar 2465 psi	P min 20 bar 290 psi	S 6,15 cm ² 0,953 in ²	SPM ~ 20 - 100 (at 20°C)	Max Speed 1,8 m/s	Maintenance kit 39BMRV01000C	Cu		L		L min		F ₀		F _{1i} *		F _{1p} **		V ₀		PED 2014/68/EU			
											mm	inch	mm	inch	mm	inch	daN	lb	daN	lb	daN	lb	cm ³	in ³	~Kg	~lb	✓	✓
RT 1200 - 010 - A											10	0.39	72	2.83	62	2.44	1060 ± 5%	2383	1462	3287	1670	3754	26,0	1,59	0,68	1,50	✓	✓
RT 1200 - 013 - A											13	0.51	78	3.07	65	2.56			1521	3419	1755	3946	31,0	1,89	0,70	1,54	✓	✓
RT 1200 - 016 - A											16	0.63	84	3.31	68	2.68			1566	3522	1823	4098	35,0	2,14	0,73	1,61	✓	✓
RT 1200 - 019 - A											19	0.75	90	3.54	71	2.80			1603	3604	1878	4221	40,0	2,44	0,75	1,65	✓	✓
RT 1200 - 025 - A											25	0.98	102	4.02	77	3.03			1658	3728	1961	4408	50,0	3,05	0,80	1,76	✓	✓
RT 1200 - 032 - A											32	1.26	116	4.57	84	3.31			1704	3830	2029	4562	61,0	3,72	0,86	1,90	✓	✓
RT 1200 - 038 - A											38	1.50	128	5.04	90	3.54			1732	3894	2073	4660	70,0	4,27	0,90	1,98	✓	✓
RT 1200 - 050 - A											50	1.97	152	5.98	102	4.02			1772	3985	2134	4798	89,0	5,43	1,00	2,20	✓	✓
RT 1200 - 063 - A											63	2.48	178	7.01	115	4.53			1801	4050	2179	4899	109,0	6,65	1,10	2,43	✓	✓
RT 1200 - 075 - A											75	2.95	202	7.95	127	5.00			1820	4092	2208	4965	128,0	7,81	1,20	2,65	✓	✓
RT 1200 - 080 - A											80	3.15	212	8.35	132	5.20	1827	4107	2218	4987	136,0	8,30	1,24	2,73	✓	✓		
RT 1200 - 100 - A											100	3.94	252	9.92	152	5.98	1847	4152	2249	5057	167,0	10,19	1,40	3,09	✓	✓		
RT 1200 - 125 - A											125	4.92	302	11.89	177	6.97	1864	4190	2275	5115	207,0	12,63	1,60	3,53	✓	✓		

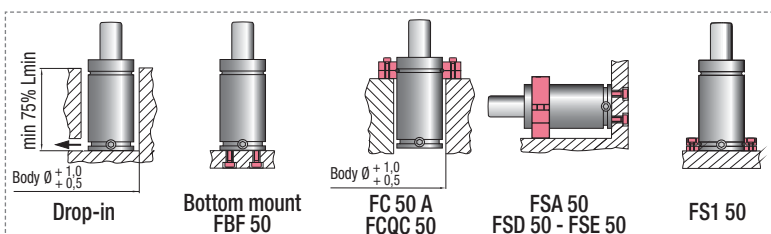

HOW TO ORDER
 (10 pcs) RT 1200-050-A
 (10 pcs) RT 1200-050-A-N

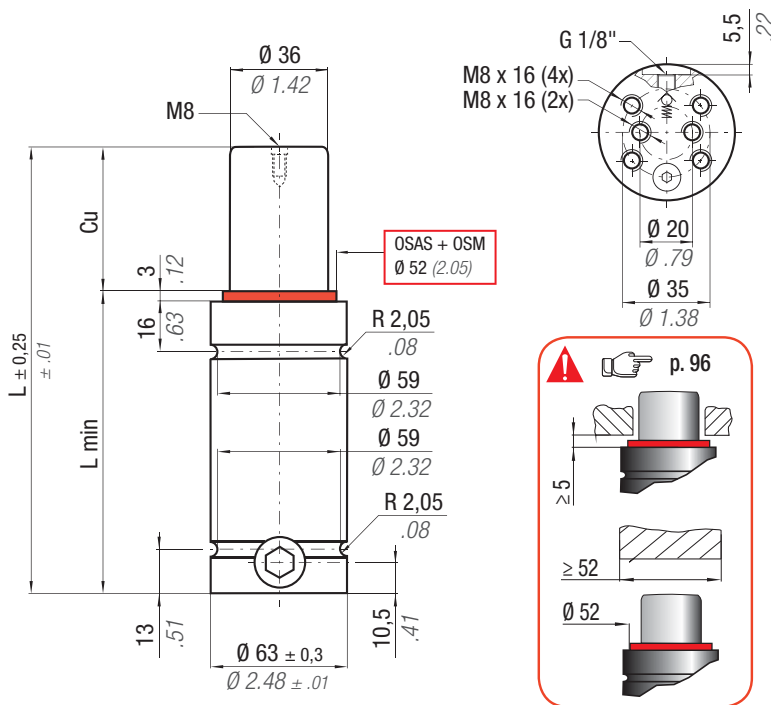

OSAS + OSM = OVER STROKE ACTIVE SAFETY + OVER STROKE MARKER

* F_{1i} = Isothermal end force at 100% Cu

** F_{1p} = Polytropic end force at 100% Cu



ACTIVE SAFETY



OSAS



USAS



OPAS

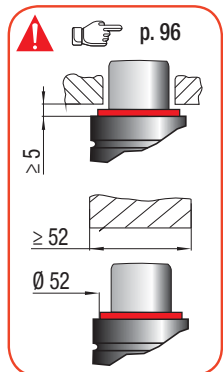

CODE	N ₂	°F 32 - 176	°C 0 - 80	ΔP $\pm 0,33\%/^{\circ}C$	P max 150 bar 2175 psi	P min 20 bar 290 psi	S 10,18 cm ² 1.578 in ²	SPM ~ 20 - 100 (at 20°C)	Max Speed 1,8 m/s	Maintenance kit 39BMRV01500C	Cu		L		L min		F ₀ Initial force		F _{1i} * End force		F _{1p} ** End force		V ₀		PED 2014/68/EU	
											mm	inch	mm	inch	mm	inch	daN	lb	daN	lb	daN	lb	cm ³	in ³	~Kg	~lb
RT 1500 - 010 - A											10	0.39	72	2.83	62	2.44	1530 3440 $\pm 5\%$	2071	4655	2395	5384	45,0	2.75	1,05	2.31	✓
RT 1500 - 013 - A										13	0.51	78	3.07	65	2.56	2149		4830	2515	5654	53,0	3.23	1,09	2.40	✓	
RT 1500 - 016 - A										16	0.63	84	3.31	68	2.68	2210		4967	2611	5870	61,0	3.72	1,13	2.49	✓	
RT 1500 - 019 - A										19	0.75	90	3.54	71	2.80	2258		5076	2687	6041	69,0	4.21	1,16	2.56	✓	
RT 1500 - 025 - A										25	0.98	102	4.02	77	3.03	2333		5245	2806	6308	85,0	5.19	1,23	2.71	✓	
RT 1500 - 032 - A										32	1.26	116	4.57	84	3.31	2394		5382	2904	6528	104,0	6.34	1,31	2.89	✓	
RT 1500 - 038 - A										38	1.50	128	5.04	90	3.54	2433		5469	2966	6668	119,0	7.26	1,38	3.04	✓	
RT 1500 - 050 - A										50	1.97	152	5.98	102	4.02	2488		5592	3055	6868	151,0	9.21	1,53	3.37	✓	
RT 1500 - 063 - A										63	2.48	178	7.01	115	4.53	2527		5681	3120	7014	186,0	11.35	1,69	3.73	✓	
RT 1500 - 075 - A										75	2.95	202	7.95	127	5.00	2553		5739	3163	7111	218,0	13.30	1,83	4.03	✓	
RT 1500 - 080 - A										80	3.15	212	8.35	132	5.20	2562	5759	3177	7142	231,0	14.09	1,89	4.17	✓		
RT 1500 - 100 - A										100	3.94	252	9.92	152	5.98	2589	5821	3222	7243	284,0	17.32	2,12	4.67	✓		
RT 1500 - 125 - A										125	4.92	302	11.89	177	6.97	2612	5872	3260	7329	350,0	21.35	2,41	5.31	✓		

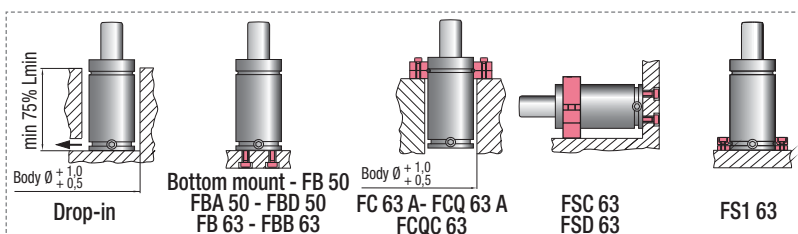

HOW TO ORDER

(10 pcs) RT 1500-050-A
(10 pcs) RT 1500-050-A-N



OSAS + OSM

OVER STROKE ACTIVE SAFETY + OVER STROKE MARKER

ACTIVE SAFETY

easu MANIFOLD p. 211



OSAS

* F_{1i} = Isothermal end force at 100% Cu p. 16

** F_{1p} = Polytropic end force at 100% Cu p. 16



USAS



OPAS

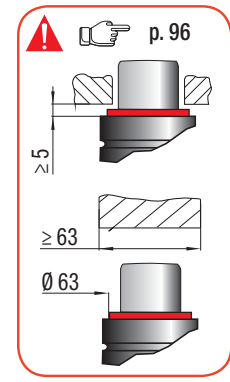
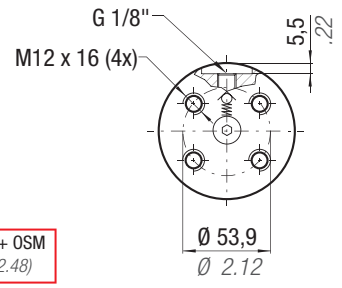
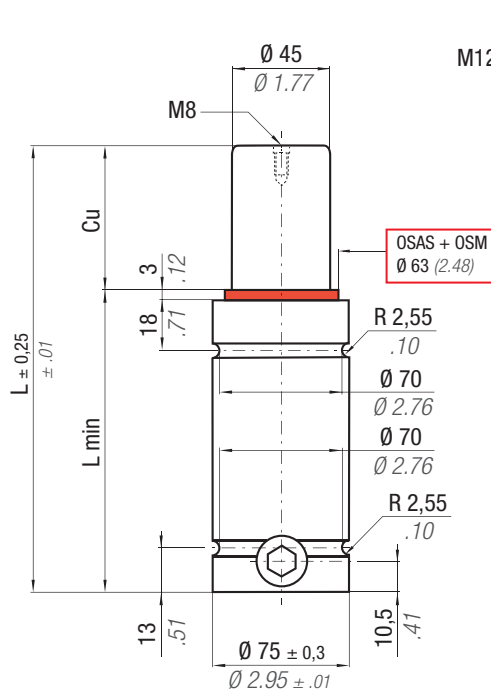

	$^{\circ}\text{F}$ 32 - 176	$^{\circ}\text{C}$ 0 - 80	ΔP $\pm 0,33\% / ^{\circ}\text{C}$	P max 150 bar 2175 psi	P min 20 bar 290 psi	S 15,90 cm ² 2.465 in ²	SPM ~ 20 - 100 (at 20°C)	Max Speed 1,8 m/s	Maintenance kit 39BMRV02400C
--	--------------------------------------	------------------------------------	---	-------------------------------------	-----------------------------------	--	---------------------------------------	-----------------------------	--

CODE	Cu		L		L min		F ₀		F _{1i} *		F _{1p} **		V ₀		PED			
	mm	inch	mm	inch	mm	inch	daN	lb	daN	lb	daN	lb	cm ³	in ³	~Kg	~lb	2014/68/EU	
RT 2400 - 010 - A	10	0.39	79	3.11	69	2.72	2385 ± 5%	5362	3125	7026	3574	8035	78,0	4.76	1,44	3.17	✓	
RT 2400 - 013 - A	13	0.51	85	3.35	72	2.83			3249	7305	3763	8460	90,0	5.49	1,64	3.62	✓	
RT 2400 - 016 - A	16	0.63	91	3.58	75	2.95			3350	7532	3920	8813	103,0	6.28	1,74	3.84	✓	
RT 2400 - 019 - A	19	0.75	97	3.82	78	3.07			3434	7721	4051	9107	115,0	7.02	1,78	3.92	✓	
RT 2400 - 025 - A	25	0.98	109	4.29	84	3.31			3566	8016	4258	9572	139,0	8.48	1,88	4.14	✓	
RT 2400 - 032 - A	32	1.26	123	4.84	91	3.58			3678	8268	4436	9973	170,0	10.37	1,99	4.39	✓	
RT 2400 - 038 - A	38	1.50	135	5.31	97	3.82			150 bar	3751	8433	4554	10238	191,0	11.65	2,08	4.59	✓
RT 2400 - 050 - A	50	1.97	159	6.26	109	4.29			2175 psi	3858	8672	4726	10624	239,0	14.58	2,27	5.00	✓
RT 2400 - 063 - A	63	2.48	185	7.28	122	4.80			+ 20 °C +68 °F	3937	8850	4855	10914	292,0	17.81	2,48	5.47	✓
RT 2400 - 075 - A	75	2.95	209	8.23	134	5.28			3989	8969	4942	11110	340,0	20.74	2,67	5.89	✓	
RT 2400 - 080 - A	80	3.15	219	8.62	139	5.47	4008	9010	4972	11178	360,0	21.96	2,74	6.04	✓			
RT 2400 - 100 - A	100	3.94	259	10.20	159	6.26	4065	9138	5066	11389	441,0	26.90	3,06	6.75	✓			
RT 2400 - 125 - A	125	4.92	309	12.17	184	7.24	4113	9247	5147	11571	541,0	33.00	3,45	7.61	✓			

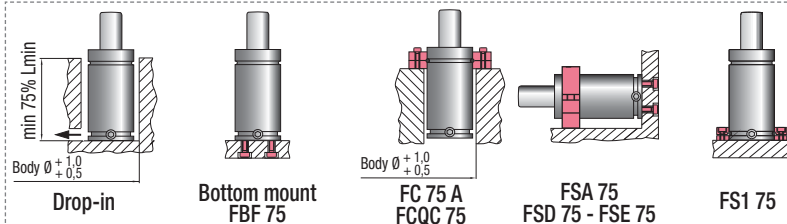

HOW TO ORDER

(10 pcs) RT 2400-050-A
(10 pcs) RT 2400-050-A-N

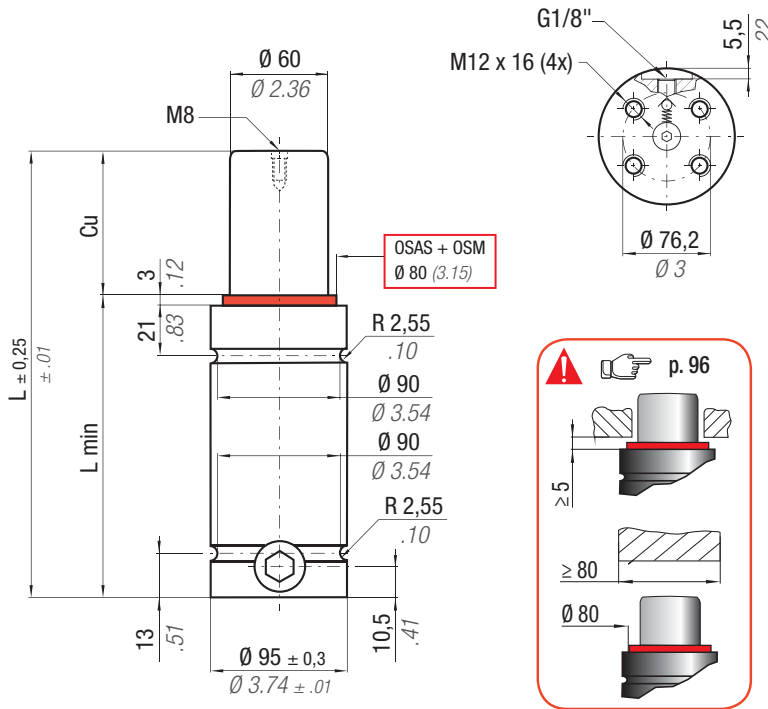

OSAS + OSM = OVER STROKE ACTIVE SAFETY + OVER STROKE MARKER



easu MANIFOLD p. 211

ACTIVE SAFETY

* F_{1i} =

Isothermal end force at 100% Cu

p. 16

** F_{1p} =

Polytropic end force at 100% Cu



OSAS



USAS



OPAS

CODE	N ₂		ΔP ± 0,33 %/°C	P max 150 bar 2175 psi	P min 20 bar 290 psi	S 28,27 cm ² 4.382 in ²	SPM ~ 20 - 100 (at 20°C)	Max Speed 1,8 m/s	Maintenance kit 39BMRV04200C	Cu		L		L min		F ₀ Initial force		F _{1i} * End force		F _{1p} ** End force		V ₀		PED 2014/68/EU	
	mm	inch								mm	inch	mm	inch	daN	lb	daN	lb	daN	lb	cm ³	in ³	~Kg	~lb	✓	✓
RT 4200 - 016 - A	16	0.63	94	3.70	78	3.07	4240 ± 5% 9532 150 bar 2175 psi + 20 °C +68 °F	6073	13653	7150	16074	174,0	10.61	2,97	6.55	✓									
RT 4200 - 019 - A	19	0.75	100	3.94	81	3.19		6238	14024	7409	16656	194,0	11.83	3,05	6.72	✓									
RT 4200 - 025 - A	25	0.98	112	4.41	87	3.43		6499	14609	7823	17587	235,0	14.34	3,20	7.05	✓									
RT 4200 - 032 - A	32	1.26	126	4.96	94	3.70		6723	15113	8183	18396	282,0	17.20	3,37	7.43	✓									
RT 4200 - 038 - A	38	1.50	138	5.43	100	3.94		6870	15443	8421	18931	323,0	19.70	3,52	7.76	✓									
RT 4200 - 050 - A	50	1.97	162	6.38	112	4.41		7085	15928	8774	19725	404,0	24.64	3,82	8.42	✓									
RT 4200 - 063 - A	63	2.48	188	7.40	125	4.92		7246	16289	9039	20320	492,0	30.01	4,14	9.13	✓									
RT 4200 - 075 - A	75	2.95	212	8.35	137	5.39		7354	16533	9219	20725	573,0	34.95	4,44	9.79	✓									
RT 4200 - 080 - A	80	3.15	222	8.74	142	5.59		7391	16616	9281	20865	606,0	36.97	4,57	10.08	✓									
RT 4200 - 100 - A	100	3.94	262	10.31	162	6.38		7509	16880	9477	21305	742,0	45.26	5,07	11.18	✓									
RT 4200 - 125 - A	125	4.92	312	12.28	187	7.36	7609	17105	9645	21683	911,0	55.57	5,69	12.54	✓										

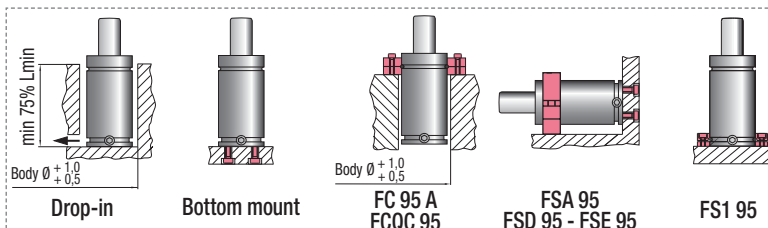

HOW TO ORDER

(10 pcs) RT 4200-050-A
(10 pcs) RT 4200-050-A-N



OSAS + OSM

OVER STROKE ACTIVE SAFETY + OVER STROKE MARKER

ACTIVE SAFETY

easyl MANIFOLD p. 211



OSAS

* $F_{1i} =$

Isothermal end force at 100% Cu p. 16

** $F_{1p} =$

Polytropic end force at 100% Cu



USAS



OPAS

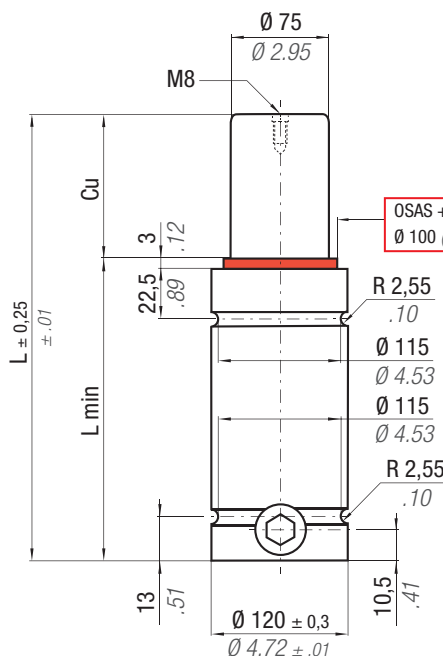

OSAS + OSM
Ø 100 (3.94)

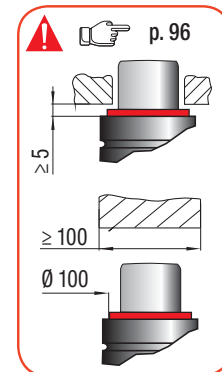

	N₂	°F 32 - 176	°C 0 - 80	ΔP ± 0,33 %/°C	P max 150 bar 2175 psi	P min 20 bar 290 psi	S 44,18 cm ² 6.848 in ²	SPM ~ 20 - 100 (at 20°C)	Max Speed 1,8 m/s	Maintenance kit 39BMRV06600C
--	----------------------	-----------------------------	---------------------------	--------------------------	-------------------------------------	-----------------------------------	--	---------------------------------------	-----------------------------	--

CODE	Cu		L		L min		F ₀		F _{1i} *		F _{1p} **		V ₀		PED		
	mm	inch	mm	inch	mm	inch	daN	lb	daN	lb	daN	lb	cm ³	in ³	~Kg	~lb	2014/68/EU
RT 6600 - 016 - A	16	0.63	104	4.09	88	3.46	6630 ± 5%	14904	9032	20306	10464	23524	309,0	18.85	5,41	11.93	✓
RT 6600 - 019 - A	19	0.75	110	4.33	91	3.58			9281	20864	10847	24385	341,0	20.80	5,53	12.19	✓
RT 6600 - 025 - A	25	0.98	122	4.80	97	3.82			9684	21771	11478	25804	405,0	24.71	5,77	12.72	✓
RT 6600 - 032 - A	32	1.26	136	5.35	104	4.09			10044	22579	12047	27083	479,0	29.22	6,05	13.34	✓
RT 6600 - 038 - A	38	1.50	148	5.83	110	4.33			10286	23124	12435	27955	544,0	33.18	6,25	13.78	✓
RT 6600 - 050 - A	50	1.97	172	6.77	122	4.80			10652	23946	13025	29281	672,0	40.99	6,77	14.93	✓
RT 6600 - 063 - A	63	2.48	198	7.80	135	5.31			10932	24577	13483	30311	811,0	49.47	7,25	15.98	✓
RT 6600 - 075 - A	75	2.95	222	8.74	147	5.79			11125	25011	13800	31024	939,0	57.28	7,77	17.13	✓
RT 6600 - 080 - A	80	3.15	232	9.13	152	5.98			11193	25162	13910	31271	992,0	60.51	7,97	17.57	✓
RT 6600 - 100 - A	100	3.94	272	10.71	172	6.77			11407	25643	14264	32067	1206,0	73.57	8,76	19.31	✓
RT 6600 - 125 - A	125	4.92	322	12.68	197	7.76	11593	26061	14574	32764	1473,0	89.85	9,76	21.52	✓		

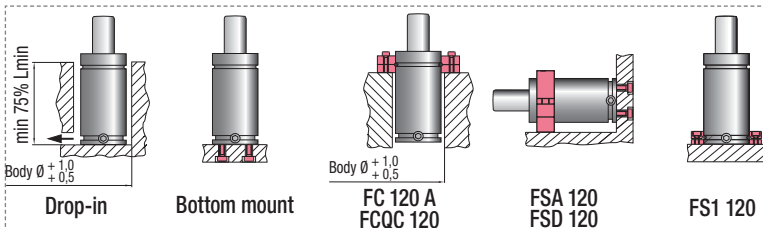

HOW TO ORDER

(10 pcs) RT 6600-050-A
(10 pcs) RT 6600-050-A-N

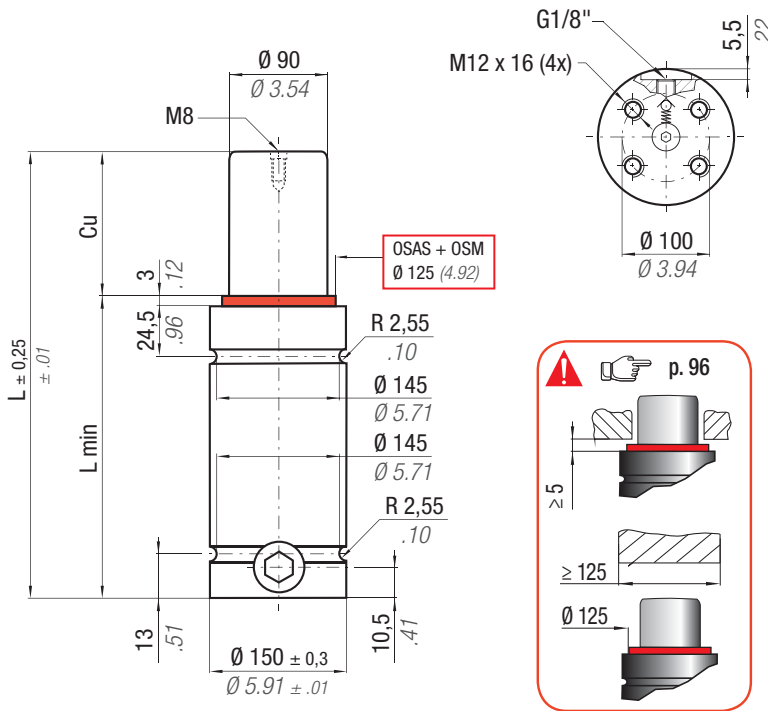

OSAS + OSM = OVER STROKE ACTIVE SAFETY + OVER STROKE MARKER



easu MANIFOLD p. 211

ACTIVE SAFETY

* F_i =

Isothermal end force at 100% Cu p. 16

** F_p =

Polytrophic end force at 100% Cu



OSAS



USAS



OPAS

	°F 32 - 176	°C 0 - 80	ΔP ± 0,33 %/°C	P max 150 bar 2175 psi	P min 20 bar 290 psi	S 63,62 cm ² 9.864 in ²	SPM ~ 20 - 100 (at 20°C)	Max Speed 1,8 m/s	Maintenance kit 39BMRV09500C
--	----------------------	--------------------	-------------------	------------------------------	----------------------------	---	--------------------------------	----------------------	---------------------------------

CODE	Cu		L		L min		F ₀ Initial force		F _i * End force		F _p ** End force		V ₀		PED 2014/68/EU		
	mm	inch	mm	inch	mm	inch	daN	lb	daN	lb	daN	lb	cm ³	in ³	~Kg	~lb	
RT 9500 - 019 - A	19	0.75	116	4.57	97	3.82	9540 ± 5% 150 bar 2175 psi + 20 °C +68 °F	21446	13206	29688	15375	34564	506,0	30.87	9,58	21.12	✓
RT 9500 - 025 - A	25	0.98	128	5.04	103	4.06			13741	30892	16208	36437	603,0	36.78	9,95	21.94	✓
RT 9500 - 032 - A	32	1.26	142	5.59	110	4.33			14214	31954	16952	38110	716,0	43.68	10,39	22.91	✓
RT 9500 - 038 - A	38	1.50	154	6.06	116	4.57			14530	32665	17455	39240	812,0	49.53	10,76	23.72	✓
RT 9500 - 050 - A	50	1.97	178	7.01	128	5.04			15003	33729	18214	40947	1006,0	61.37	11,51	25.38	✓
RT 9500 - 063 - A	63	2.48	204	8.03	141	5.55			15364	34539	18797	42257	1215,0	74.12	12,32	27.16	✓
RT 9500 - 075 - A	75	2.95	228	8.98	153	6.02			15610	35093	19198	43159	1409,0	85.95	13,07	28.81	✓
RT 9500 - 080 - A	80	3.15	238	9.37	158	6.22			15696	35285	19338	43474	1489,0	90.83	13,38	29.50	✓
RT 9500 - 100 - A	100	3.94	278	10.94	178	7.01			15967	35895	19783	44474	1812,0	110.53	14,63	32.25	✓
RT 9500 - 125 - A	125	4.92	328	12.91	203	7.99	16202	36423	20170	45344	2215,0	135.12	16,19	35.69	✓		

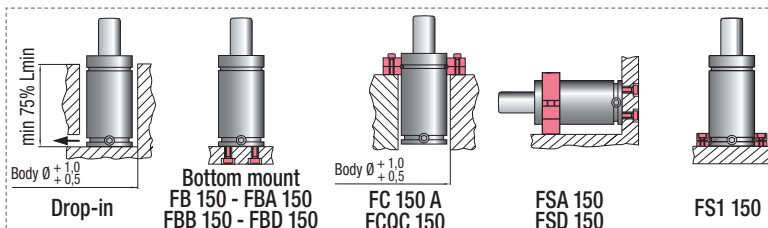

HOW TO ORDER

(10 pcs) RT 9500-050-A
(10 pcs) RT 9500-050-A-N

MB	Renault	Suzuki

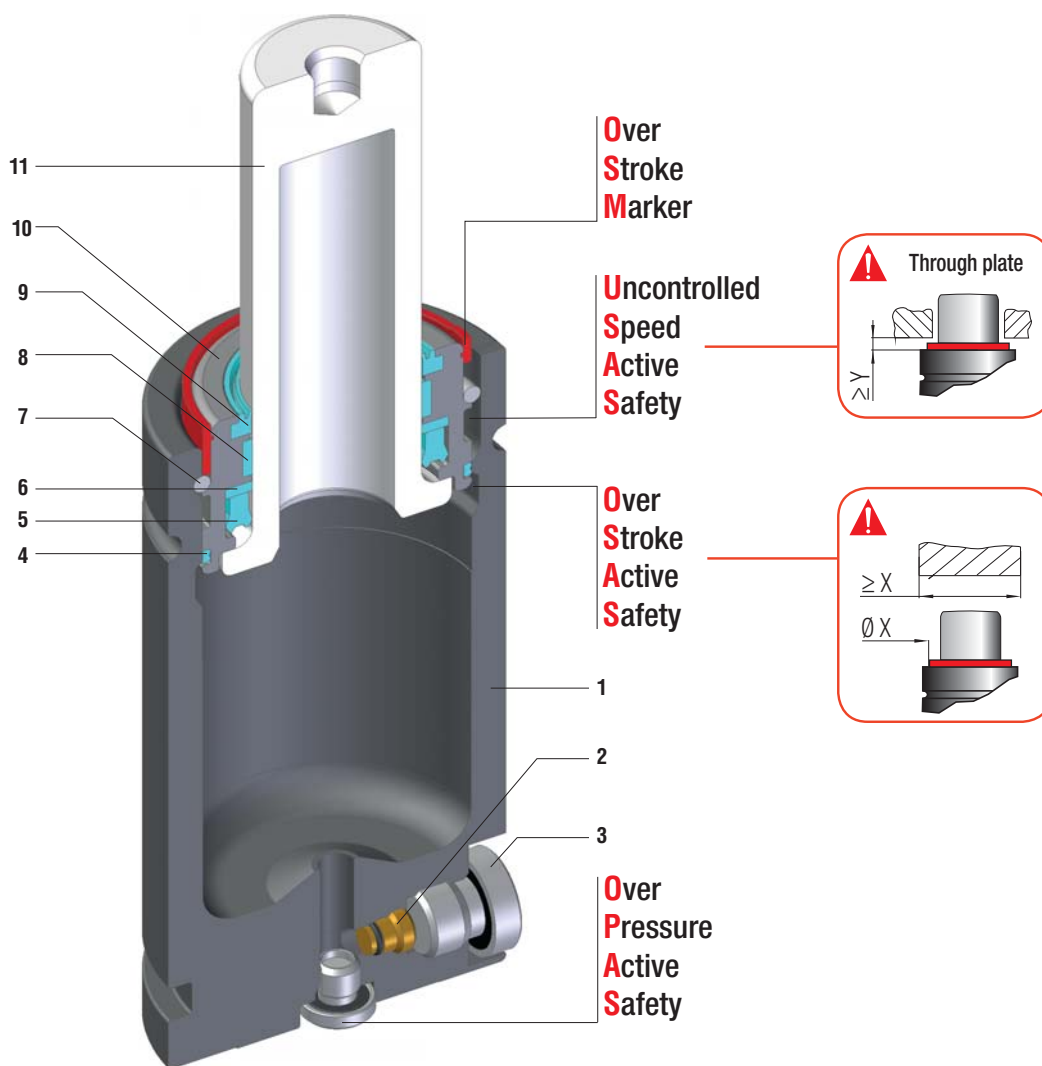

Forze ISO, altezza ridotta - ISO forces, reduced height - ISO Kräfte, Reduzierte Höhe
 Forces ISO, Hauteur réduite - ISO fuerzas, altura reducida - Forças ISO, altura reduzida

SEALING	ROD SEAL
DESIGN	BUSH - BODY DESIGN

1	Body	5	Rod seal	9	Rod wiper
2	Valve	6	Back-up ring	10	Bush
3	Plug	7	Retaining ring	11	Rod (nitrited superfinished)
4	Dual ring seal	8	Guide ring		

RANGE CHART

Model	Body Ø		Stroke Cu		Initial force F0					
	mm	inch	mm	inch	daN	lb				
S 500	45	1.77	6 - 125	0.24 - 4.92	470	1057	-	-	-	-
S 750	50	1.97	6 - 125	0.24 - 4.92	740	1664	✓	✓	✓	-
S 1500	75	2.95	25 - 100	0.98 - 3.94	1530	3440	-	-	✓	-
S 3000	95	3.74	25 - 100	0.98 - 3.94	2945	6621	-	-	✓	-



HOW TO ORDER

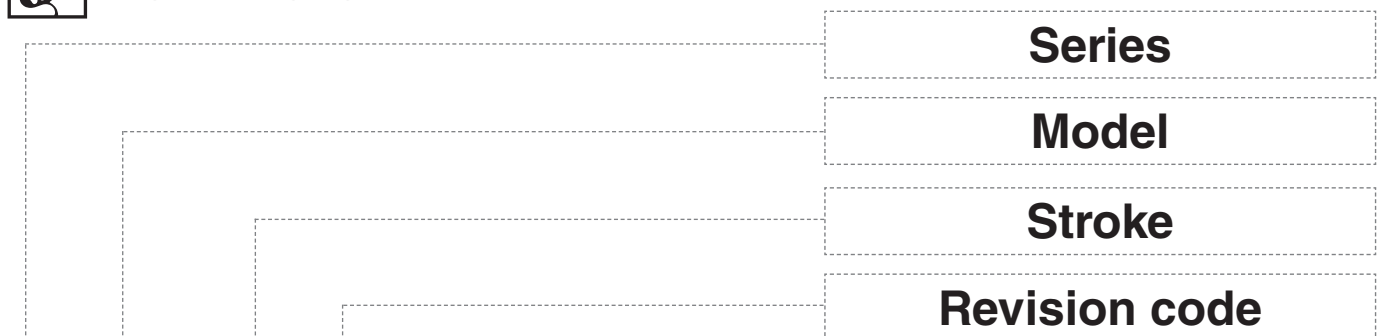

S 1500-050-A - N - E

IT Codice cilindro autonomo
EN Self-contained cylinder code
DE Kode des eingeständigen Gdf.
FR Code du cylindre autonome
ES Código del cilindro autónomo
PT Código do cilindro autónomo

IT Collegabile con tubi, cilindro fornito scarico e senza valvola unidirezionale
EN Linkable with hoses, cylinder supplied without pressure and oneway valve
DE Anschlussfähig mit Leitungen, Gdf. geliefert ohne Druck und RückschlagVentil
FR Connectable avec tubes, ressort fourni sans pression ni valve unidirectionelle
ES Connectable con tubos, cilindro suministrado sin presión y sin válvula unidireccional
PT Acompláveis com tubos, cilindro fornecidos sem pressão e sem válvula unidireccional

IT Collegabile EASY MANIFOLD, fornito scarico + guarnizione di collegamento
EN Linkable EASY MANIFOLD, supplied without pressure + connecting seal
DE Anschlussfähig EASY MANIFOLD, geliefert ohne Druck + Verbindungsdichtung
FR Connectable EASY MANIFOLD, fourni sans pression + joint de connexion
ES Connectable EASY MANIFOLD, suministrado sin presión + junta de conexión
PT Acompláveis EASY MANIFOLD, fornecidos sem pressão + vedantes de conexão

ACTIVE SAFETY

* $F_{1i} =$

Isothermal end force at 100% Cu



p. 16



** $F_{1p} =$

Polytropic end force at 100% Cu

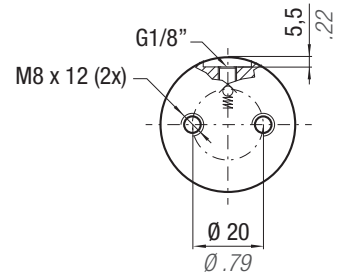
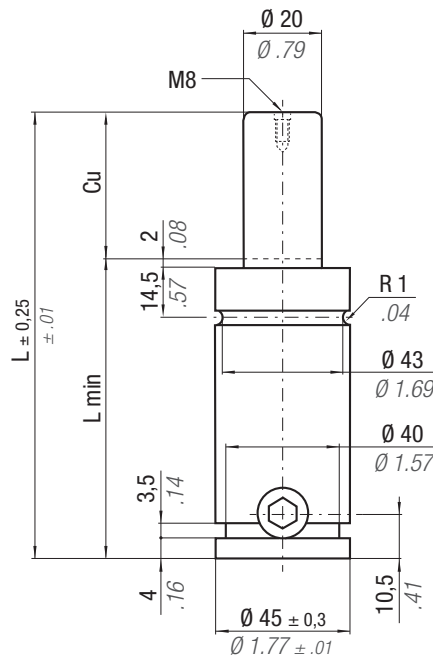

CODE	N ₂	°F 32 - 176	°C 0 - 80	ΔP ± 0,33 %/°C	P max 150 bar 2175 psi	P min 20 bar 290 psi	S 3,14 cm ² 0,487 in ²	SPM ~ 40 - 100 (at 20°C)	Max Speed 1,8 m/s	Maintenance kit 39BMS00500A	PED 2014/68/EU	
												Cu
S 500 - 006 - A												✓
S 500 - 013 - A												✓
S 500 - 019 - A												✓
S 500 - 025 - A												✓
S 500 - 038 - A												✓
S 500 - 050 - A												✓
S 500 - 063 - A												✓
S 500 - 080 - A												✓
S 500 - 100 - A												✓
S 500 - 125 - A												✓

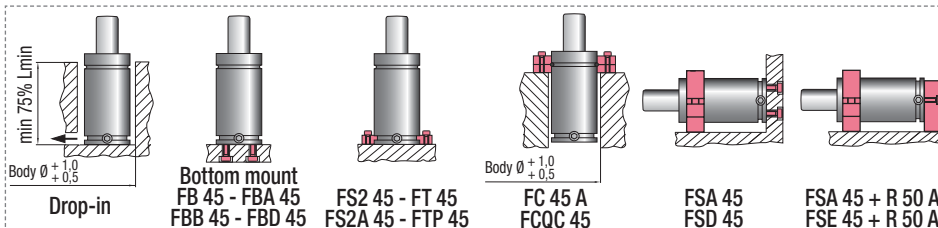

HOW TO ORDER

(10 pcs) S 500-050-A
(10 pcs) S 500-050-A-N

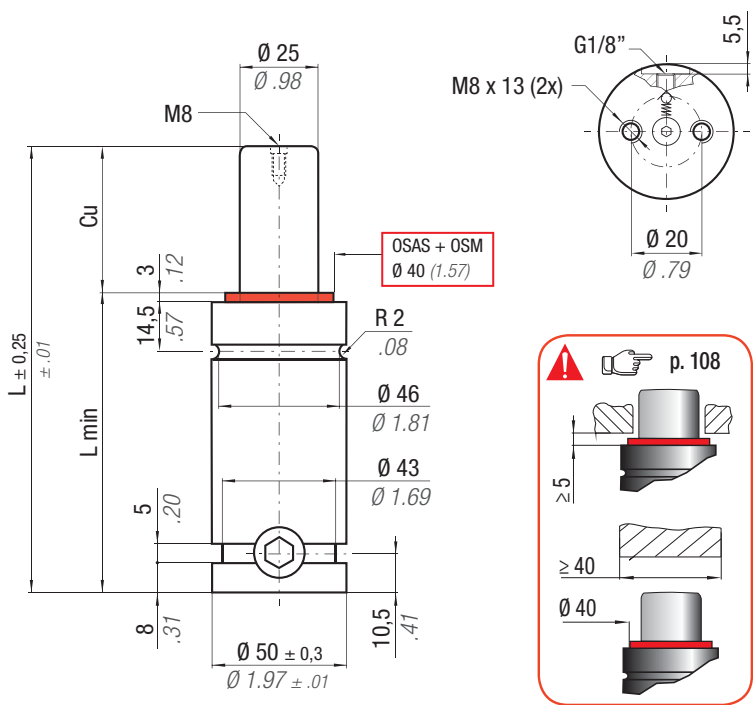

OSAS + OSM = OVER STROKE ACTIVE SAFETY + OVER STROKE MARKER

* F_{1i} = Isothermal end force at 100% Cu p. 16
 ** F_{1p} = Polytropic end force at 100% Cu



	$^{\circ}\text{F}$ 32 - 176	$^{\circ}\text{C}$ 0 - 80	ΔP $\pm 0,33\% / ^{\circ}\text{C}$	P max 150 bar 2175 psi	P min 20 bar 290 psi	S 4,91 cm ² 0,761 in ²	SPM ~ 30 - 80 (at 20°C)	Max Speed 1,8 m/s	Maintenance kit 39BMS00750B
--	--------------------------------------	------------------------------------	---	-------------------------------------	-----------------------------------	---	--------------------------------------	-----------------------------	---------------------------------------

CODE PHASING OUT from 01/2018	NEW	Cu		L		L min		F ₀ Initial force		F _{1i} * End force		F _{1p} ** End force		V ₀		PED 2014/68/EU		
		mm	inch	mm	inch	mm	inch	daN	lb	daN	lb	daN	lb	cm ³	in ³	~Kg	~lb	✓
S 750 - 006 - A	S 750 - 006 - B	6	0.24	62	2.44	56	2.20	740 1664 ± 5% 150 bar 2175 psi + 20 °C +68 °F		909	2044	1019	2291	18,0	1.10	0,60	1.32	✓
S 750 - 013 - A	S 750 - 013 - B	13	0.51	76	2.99	63	2.48			995	2237	1149	2583	29,0	1.77	0,66	1.46	✓
S 750 - 019 - A	S 750 - 019 - B	19	0.75	88	3.46	69	2.72			1035	2327	1212	2725	38,0	2.32	0,71	1.57	✓
S 750 - 025 - A	S 750 - 025 - B	25	0.98	100	3.94	75	2.95			1062	2387	1253	2817	46,0	2.81	0,75	1.65	✓
S 750 - 038 - A	S 750 - 038 - B	38	1.50	126	4.96	88	3.46			1096	2464	1307	2938	66,0	4.03	0,85	1.87	✓
S 750 - 050 - A	S 750 - 050 - B	50	1.97	150	5.91	100	3.94			1114	2504	1336	3003	84,0	5.12	0,95	2.09	✓
S 750 - 063 - A	S 750 - 063 - B	63	2.48	176	6.93	113	4.45			1128	2536	1357	3051	103,0	6.28	1,05	2.31	✓
S 750 - 080 - A	S 750 - 080 - B	80	3.15	210	8.27	130	5.12			1139	2561	1375	3091	128,0	7.81	1,18	2.60	✓
S 750 - 100 - A	S 750 - 100 - B	100	3.94	250	9.84	150	5.91			1148	2581	1390	3125	158,0	9.64	1,33	2.93	✓
S 750 - 125 - A	S 750 - 125 - B	125	4.92	300	11.81	175	6.89			1155	2597	1401	3150	195,0	11.90	1,52	3.35	✓

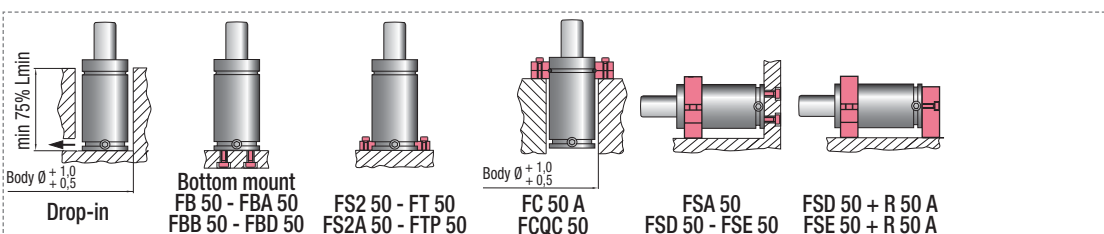

HOW TO ORDER
 (10 pcs) S 750-050-B
 (10 pcs) S 750-050-B-N



p. 211

ACTIVE SAFETY

* $F_{1i} =$

Isothermal end force at 100% Cu

p. 16

** $F_{1p} =$

Polytropic end force at 100% Cu



OPAS

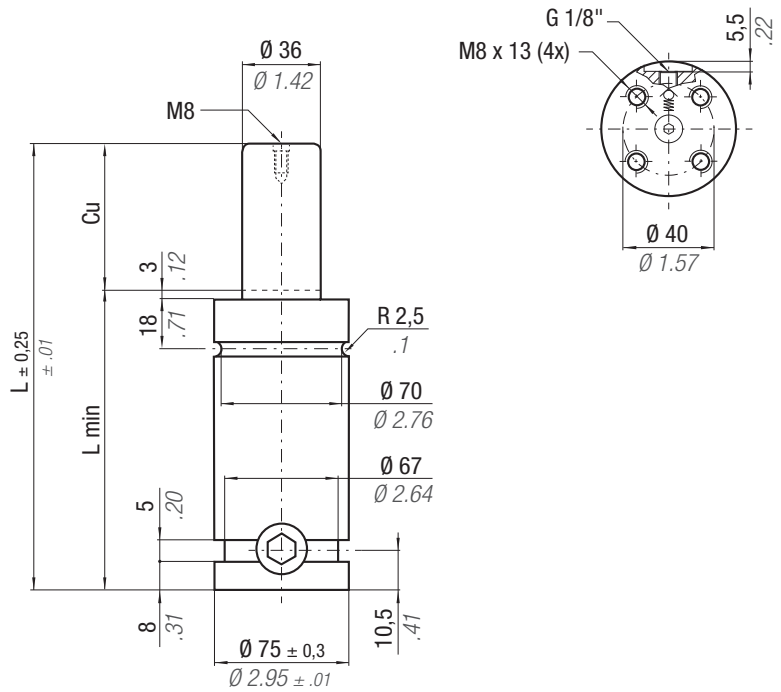

CODE	N ₂	°F 32 - 176	°C 0 - 80	ΔP $\pm 0,33 \%/^{\circ}C$	P max 150 bar 2175 psi	P min 20 bar 290 psi	S 10,18 cm ² 1,578 in ²	SPM ~ 20 - 80 (at 20°C)	Max Speed 1,8 m/s	Maintenance kit 39BMS01500A	Vo		PED		
											mm	inch	~Kg	~lb	2014/68/EU
S 1500 - 025 - A											25	0,98	2,25	4,96	✓
S 1500 - 038 - A											38	1,50	2,53	5,58	✓
S 1500 - 050 - A											50	1,97	2,78	6,13	✓
S 1500 - 063 - A											63	2,48	3,06	6,75	✓
S 1500 - 080 - A											80	3,15	3,42	7,54	✓
S 1500 - 100 - A											100	3,94	3,84	8,47	✓

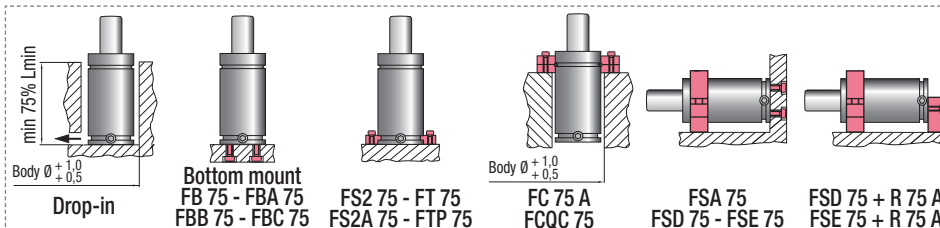

HOW TO ORDER

(10 pcs) S 1500-050-A
(10 pcs) S 1500-050-A-N

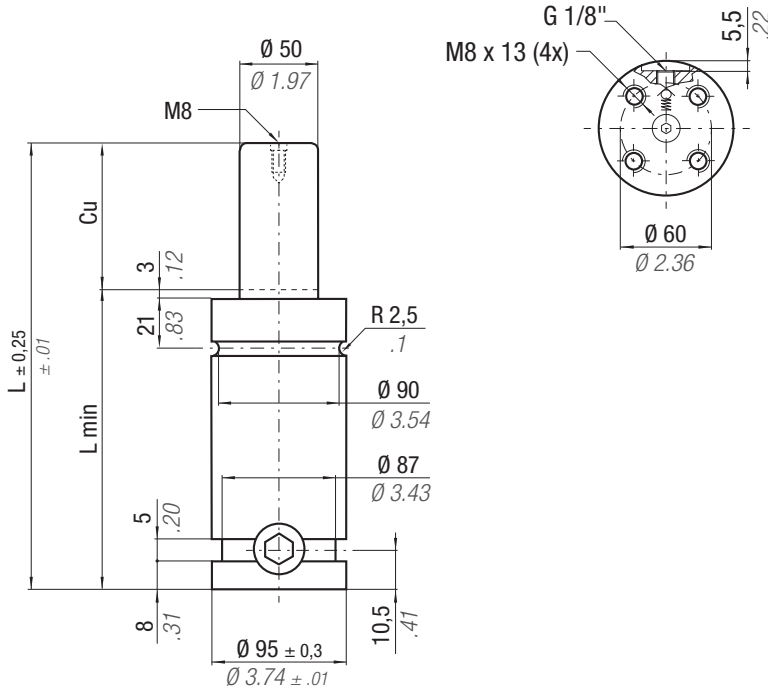

easu MANIFOLD p. 211

* $F_{1i} =$

Isothermal end force at 100% Cu p. 16

** $F_{1p} =$

Polytropic end force at 100% Cu

ACTIVE SAFETY



	$^{\circ}F$ 32 - 176	$^{\circ}C$ 0 - 80	ΔP $\pm 0,33 \% / ^{\circ}C$	P max 150 bar 2175 psi	P min 20 bar 290 psi	S 19,63 cm ² 3,043 in ²	SPM ~ 15 - 60 (at 20°C)	Max Speed 1,8 m/s	Maintenance kit 39BMS03000A
--	-------------------------------	-----------------------------	---	-------------------------------------	-----------------------------------	--	--------------------------------------	-----------------------------	---------------------------------------

CODE	Cu		L		L min		F ₀		F _{1i} *		F _{1p} **		V ₀		PED		
	mm	inch	mm	inch	mm	inch	daN	lb	daN	lb	daN	lb	cm ³	in ³	~Kg	~lb	2014/68/EU
S 3000 - 025 - A	25	0.98	120	4.72	95	3.74	2945	6621	4860	10927	5995	13477	143,0	8.72	4,13	9.11	✓
S 3000 - 038 - A	38	1.50	146	5.75	108	4.25	$\pm 5\%$		5101	11467	6391	14368	202,0	12.32	4,61	10.16	✓
S 3000 - 050 - A	50	1.97	170	6.69	120	4.72	150 bar 2175 psi		5233	11764	6612	14865	256,0	15.62	5,04	11.11	✓
S 3000 - 063 - A	63	2.48	196	7.72	133	5.24			5328	11979	6773	15227	315,0	19.22	5,51	12.15	✓
S 3000 - 080 - A	80	3.15	230	9.06	150	5.91			5413	12168	6916	15547	392,0	23.91	6,13	13.51	✓
S 3000 - 100 - A	100	3.94	270	10.63	170	6.69	+ 20 °C +68 °F		5479	12317	7028	15800	483,0	29.46	6,86	15.12	✓

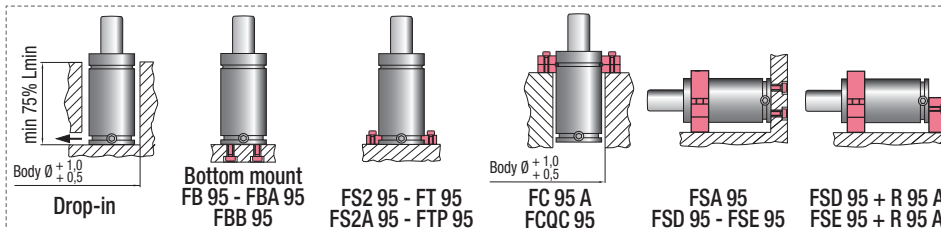

HOW TO ORDER

(10 pcs) S 3000-050-A
(10 pcs) S 3000-050-A-N

ISO	VDI	BMW
FCA	Ford	Mazda
MB	Nissan	PSA
Reanult	Suzuki	VW

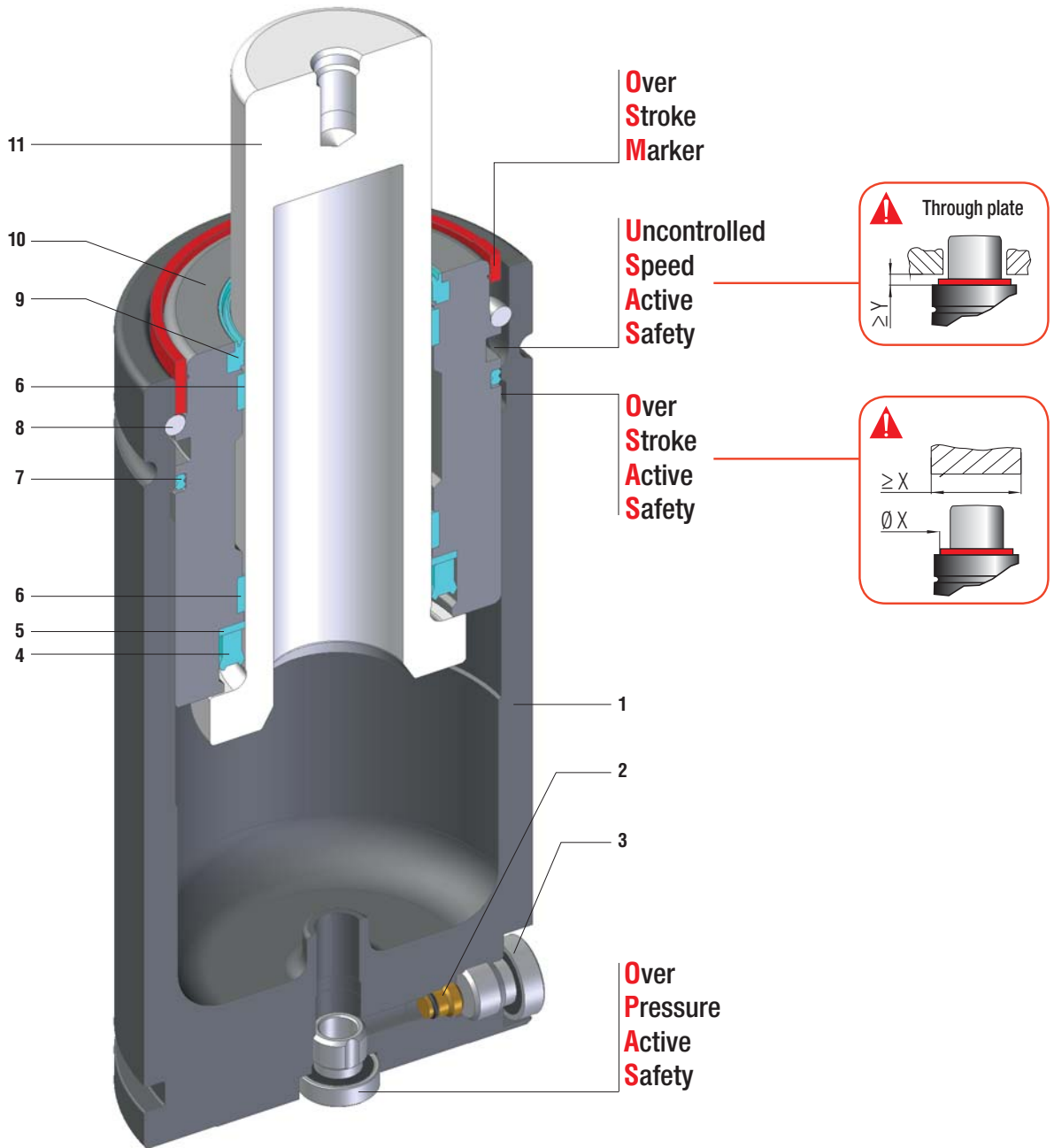

ISO 11901 standard - ISO 11901 standard - ISO 11901 standard
 Conforme ISO 11901 - ISO 11901 standard - Norma ISO 11901

SEALING	ROD SEAL
DESIGN	BUSH - BODY DESIGN

1	Body	5	Back-up ring	9	Rod wiper
2	Valve	6	Guide ring	10	Bush
3	Plug	7	Dual ring seal	11	Rod (nitrited superfinished)
4	Rod seal	8	Retaining ring		

RANGE CHART

Model	Body Ø		Stroke Cu		Initial force F0					
	mm	inch	mm	inch	daN	lb				
SC 150	32	1.26	10 - 125	0.39 - 4.92	170	382	✓	✓	✓	-
SC 250	38	1.50	10 - 125	0.39 - 4.92	260	585	✓	✓	✓	-
SCF 250	M 38 X 1,5	M 38 X 1,5	10 - 125	0.39 - 4.92	260	585	✓	✓	✓	-
SC 500	45	1.77	10 - 200	0.39 - 6.30	470	1057	✓	✓	✓	-
SC 750	50	1.97	13 - 300	0.51 - 11.81	740	1664	✓	✓	✓	-
SC 1500	75	2.95	13 - 300	0.51 - 11.81	1530	3440	✓	✓	✓	-
SC 3000	95	3.74	13 - 300	0.51 - 11.81	2945	6621	✓	✓	✓	-
SC 5000	120	4.72	25 - 300	0.98 - 11.81	4980	11195	✓	✓	✓	-
SC 7500	150	5.91	25 - 300	0.98 - 11.81	7540	16950	✓	✓	✓	-
SC 10000	195	7.68	25 - 300	0.98 - 11.81	10600	23830	✓	✓	✓	-

SC
SCF

HOW TO ORDER



SC 1500-050-A - N - E

IT Codice cilindro autonomo
EN Self-contained cylinder code
DE Kode des eingeständigen Gdf.
FR Code du cylindre autonome
ES Código del cilindro autónomo
PT Código do cilindro autónomo

IT Collegabile con tubi, cilindro fornito scarico e senza valvola unidirezionale
EN Linkable with hoses, cylinder supplied without pressure and oneway valve
DE Anschlussfähig mit Leitungen, Gdf. geliefert ohne Druck und RückschlagVentil
FR Connectable avec tubes, ressort fourni sans pression ni valve unidirectionelle
ES Connectable con tubos, cilindro suministrado sin presión y sin válvula unidireccional
PT Acompláveis com tubos, cilindro fornecidos sem pressão e sem válvula unidireccional

IT Collegabile EASY MANIFOLD, fornito scarico + guarnizione di collegamento
EN Linkable EASY MANIFOLD, supplied without pressure + connecting seal
DE Anschlussfähig EASY MANIFOLD, geliefert ohne Druck + Verbindungsdichtung
FR Connectable EASY MANIFOLD, fourni sans pression + joint de connexion
ES Connectable EASY MANIFOLD, suministrado sin presión + junta de conexión
PT Acompláveis EASY MANIFOLD, fornecidos sem pressão + vedantes de conexão

SC 150

ISO 11901 - 1 B8 3180 220 000 001(MB)	VDI 3003 E24.54.815.G (PSA)	075.90.55 (FCA) EM24.54.700 (Renault)	B2 4006 (BMW) 39D 878 (VW)
--	--------------------------------	--	-------------------------------



OSAS + OSM = OVER STROKE ACTIVE SAFETY + OVER STROKE MARKER

ACTIVE SAFETY

easq MANIFOLD p. 211



OSAS



USAS



OPAS

* F_{1i} = Isothermal end force at 100% Cu p. 16

** F_{1p} = Polytrophic end force at 100% Cu

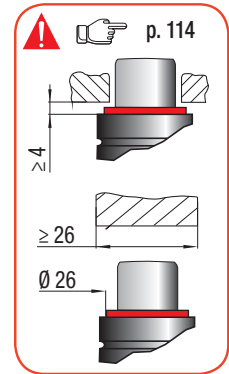
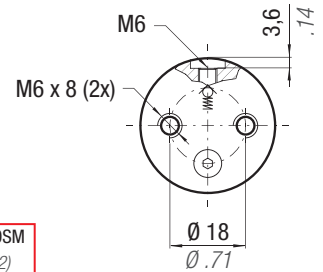
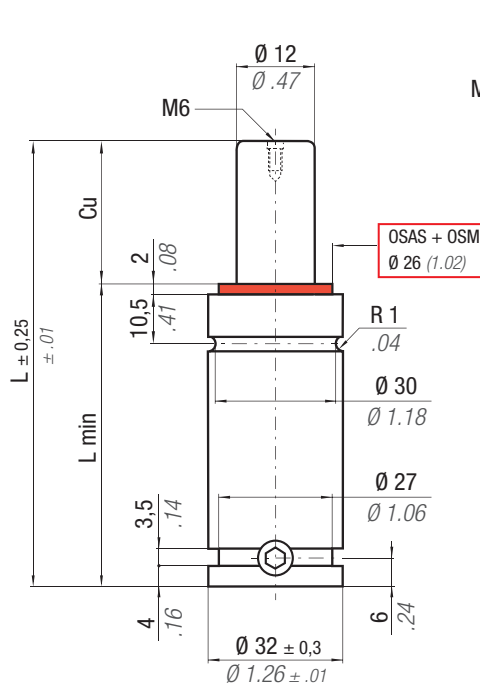

	°F 32 - 176	°C 0 - 80	ΔP $\pm 0,33 \%/^{\circ}C$	P max 150 bar 2175 psi	P min 20 bar 290 psi	S 1,13 cm ² 0.175 in ²	SPM ~ 80 - 100 (at 20°C)	Max Speed 1,8 m/s	Maintenance kit 39BMSC00150E
--	----------------------	--------------------	---------------------------------------	-------------------------------------	-----------------------------------	---	---------------------------------------	-----------------------------	--

CODE	Cu		L		L min		F ₀		F _{1i} *		F _{1p} **		V ₀		~Kg	~lb	2014/68/EU
	mm	inch	mm	inch	mm	inch	daN	lb	daN	lb	daN	lb	cm ³	in ³			
SC 150 - 010 - D	10	0.39	70	2.76	60	2.36	170 382 ± 5% 150 bar 2175 psi + 20 °C +68 °F		191	429	207	466	12,0	0.73	0,28	0,62	✓
SC 150 - 013 - D	12,7	0.51	75,4	2.97	62,7	2.47			194	435	212	476	14,0	0.85	0,29	0,64	✓
SC 150 - 016 - D	16	0.63	82	3.23	66	2.60			197	442	216	486	16,0	0.98	0,30	0,66	✓
SC 150 - 025 - D	25	0.98	100	3.94	75	2.95			202	455	224	504	21,0	1.28	0,33	0,73	✓
SC 150 - 038 - D	38	1.50	126	4.96	88	3.46			207	465	231	519	28,0	1.71	0,36	0,79	✓
SC 150 - 050 - D	50	1.97	150	5.91	100	3.94			209	471	235	528	35,0	2.14	0,40	0,88	✓
SC 150 - 063 - D	63,5	2.48	177	6.97	113,5	4.47			211	475	238	535	43,0	2.62	0,44	0,97	✓
SC 150 - 080 - D	80	3.15	210	8.27	130	5.12			213	479	240	540	52,0	3.17	0,49	1.08	✓
SC 150 - 100 - D	100	3.94	250	9.84	150	5.91			214	482	242	545	63,0	3.84	0,55	1.21	✓
SC 150 - 125 - D	125	4.92	300	11.81	175	6.89			216	485	244	549	78,0	4.76	0,64	1.41	✓

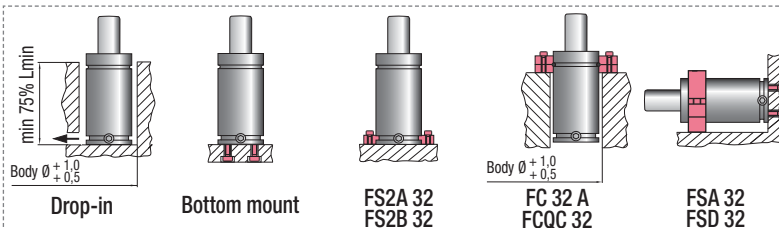

HOW TO ORDER

(10 pcs) SC 150-050-D
(10 pcs) SC 150-050-D-N

ISO 11901 - 1	VDI 3003	B2 4006 (BMW)	075.90.55 (FCA)
B8 3180 220 000 001(MB)	K 32 S (Nissan)	E24.54.815.G (PSA)	EM24.54.700 (Renault)
SES-K 5404e (Suzuki)	39D 878 (VW)		

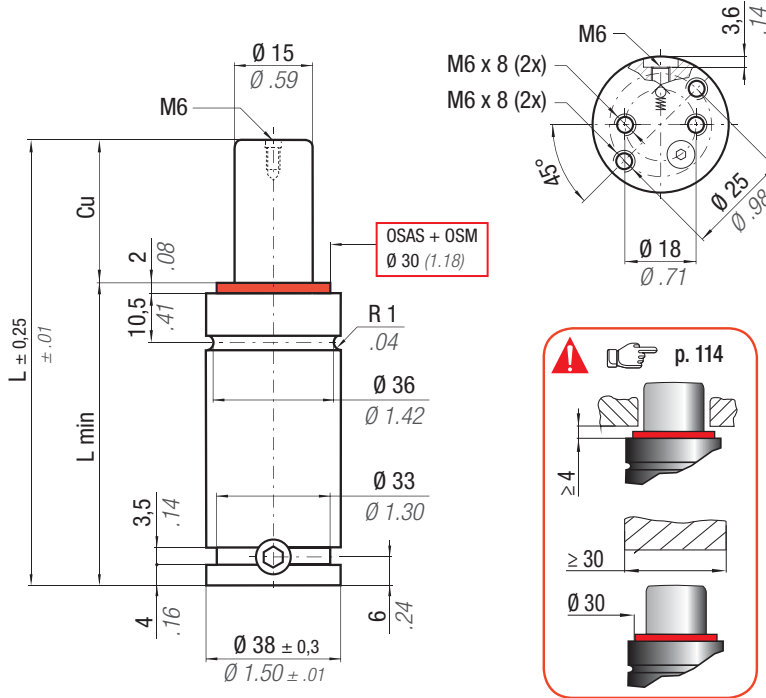

OSAS + OSM = OVER STROKE ACTIVE SAFETY + OVER STROKE MARKER

easu MANIFOLD p. 211

* F_{1i} = Isothermal end force at 100% Cu p. 16
 ** F_{1p} = Polyphoric end force at 100% Cu

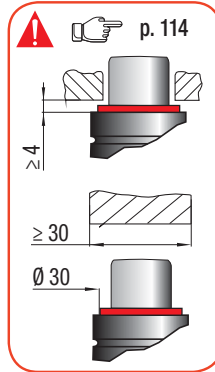

ACTIVE SAFETY



OSAS



USAS



OPAS

	°F 32 - 176 °C 0 - 80	ΔP ± 0,33 %/°C	P max 150 bar 2175 psi	P min 20 bar 290 psi	S 1,77 cm ² 0,274 in ²	SPM ~ 80 - 100 (at 20°C)	Max Speed 1,8 m/s	Maintenance kit 39BMSC00250E
--	--------------------------	---------------------------	-------------------------------------	-----------------------------------	---	---------------------------------------	-----------------------------	--

CODE	Cu		L		L min		F ₀ Initial force		F _{1i} * End force		F _{1p} ** End force		V ₀		PED 2014/68/EU		
	mm	inch	mm	inch	mm	inch	daN	lb	daN	lb	daN	lb	cm ³	in ³	~Kg	~lb	
SC 250 - 010 - D	10	0.39	70	2.76	60	2.36	260 585 ± 5% 150 bar 2175 psi + 20 °C +68 °F		303	682	332	746	16,0	0.98	0,40	0.88	✓
SC 250 - 013 - D	12,7	0.50	75,4	2.97	62,7	2.47			309	695	340	765	19,0	1.16	0,41	0.90	✓
SC 250 - 016 - D	16	0.63	82	3.23	66	2.60			315	707	348	783	21,0	1.28	0,43	0.95	✓
SC 250 - 019 - D	19	0.75	88	3.46	69	2.72			319	717	354	797	23,0	1.40	0,45	0.99	✓
SC 250 - 025 - D	25	0.98	100	3.94	75	2.95			325	731	364	818	28,0	1.71	0,48	1.06	✓
SC 250 - 038 - D	38	1.50	126	4.96	88	3.46			334	751	377	848	38,0	2.32	0,54	1.19	✓
SC 250 - 050 - D	50	1.97	150	5.91	100	3.94			339	762	385	865	47,0	2.87	0,60	1.32	✓
SC 250 - 063 - D	63,5	2.50	177	6.97	113,5	4.47			343	771	391	878	58,0	3.54	0,66	1.46	✓
SC 250 - 080 - D	80	3.15	210	8.27	130	5.12			346	778	395	889	70,0	4.27	0,74	1.63	✓
SC 250 - 100 - D	100	3.94	250	9.84	150	5.91			349	784	399	898	85,0	5.19	0,81	1.79	✓
SC 250 - 125 - D	125	4.92	300	11.81	175	6.89	351	789	403	906	105,0	6.41	0,98	2.16	✓		

SC SCF

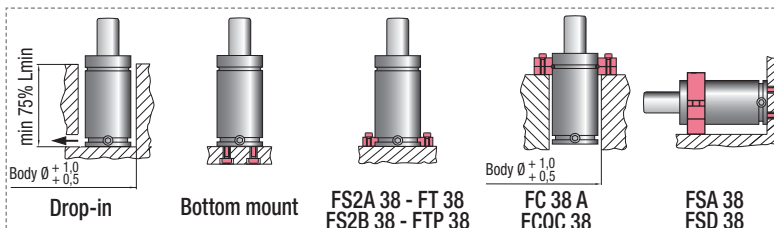

HOW TO ORDER

(10 pcs) SC 250-050-D
 (10 pcs) SC 250-050-D-N



ACTIVE SAFETY



OSAS



USAS



OPAS

OSAS + OSM = OVER STROKE ACTIVE SAFETY + OVER STROKE MARKER

Il nuovo codice sarà fornito solo ad esaurimento del vecchio

The new code will be supplied only when the old will be out of stock

Der neue Kode wird geliefert nur wenn der alte nicht mehr im Lager ist

Le nouveau code sera fourni uniquement lorsque le vieux stock sera écoulé

El nuevo código será suministrado sólo cuando el viejo está fuera de stock

O novo código irá ser fornecido apenas quando o antigo esgotar stock

* $F_{1i} =$

Isothermal end force at 100% Cu



p. 16

** $F_{1p} =$

Polytropic end force at 100% Cu

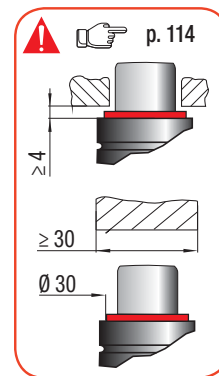
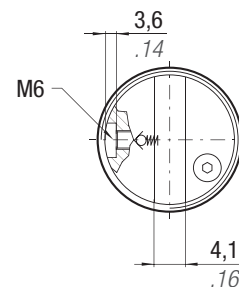
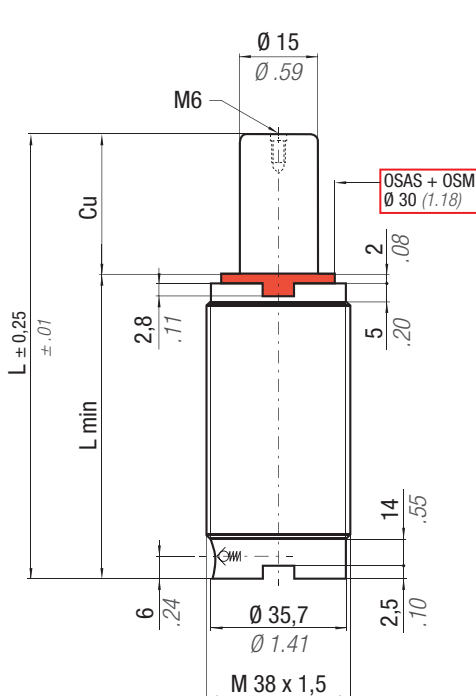

N ₂	°F 32 -176	°C 0 -80	ΔP ± 0,33 %/°C	P max 150 bar 2175 psi	P min 20 bar 290 psi	S 1,77 cm ² 0,274 in ²	SPM ~ 80 - 100 (at 20°C)	Max Speed 1,8 m/s	Maintenance kit 39BMSC00250E
----------------	------------------	----------------	---------------------------	------------------------------	----------------------------	--	--------------------------------	----------------------	---------------------------------

CODE PHASING OUT from 09/2009	NEW	Cu		L		L min		F ₀		F _{1i} *		F _{1p} **		V ₀		~Kg	~lb	PED 2014/68/EU
		mm	inch	mm	inch	mm	inch	daN	lb	daN	lb	daN	lb	cm ³	in ³			
SCF 250 - 010 - A	SCF 250 - 010 - D	10	0.39	70	2.76	60	2.36	260 585 ± 5%	150 bar 2175 psi	303	682	332	746	16,0	0.98	0,37	0.81	✓
SCF 250 - 013 - A	SCF 250 - 013 - D	12,7	0.50	75,4	2.97	62,7	2.47			309	695	340	765	19,0	1.16	0,38	0.84	✓
SCF 250 - 016 - A	SCF 250 - 016 - D	16	0.63	82	3.23	66	2.60			315	707	348	783	21,0	1.28	0,39	0.86	✓
-	SCF 250 - 019 - D	19	0.75	88	3.46	69	2.72			319	717	354	797	23,0	1.40	0,42	0.92	✓
SCF 250 - 025 - A	SCF 250 - 025 - D	25	0.98	100	3.94	75	2.95			325	731	364	818	28,0	1.71	0,44	0.97	✓
SCF 250 - 038 - A	SCF 250 - 038 - D	38	1.50	126	4.96	88	3.46			334	751	377	848	38,0	2.32	0,50	1.10	✓
SCF 250 - 050 - A	SCF 250 - 050 - D	50	1.97	150	5.91	100	3.94			339	762	385	865	47,0	2.87	0,55	1.21	✓
SCF 250 - 063 - A	SCF 250 - 063 - D	63,5	2.50	177	6.97	113,5	4.47			343	771	391	878	58,0	3.54	0,63	1.39	✓
SCF 250 - 080 - A	SCF 250 - 080 - D	80	3.15	210	8.27	130	5.12			346	778	395	889	70,0	4.27	0,70	1.54	✓
SCF 250 - 100 - A	SCF 250 - 100 - D	100	3.94	250	9.84	150	5.91			349	784	399	898	86,0	5.25	0,75	1.65	✓
SCF 250 - 125 - A	SCF 250 - 125 - D	125	4.92	300	11.81	175	6.89	351	789	403	906	105,0	6.41	0,93	2.05	✓		

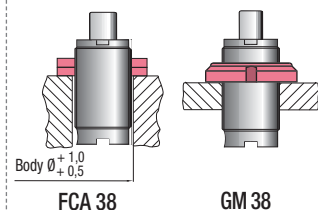

HOW TO ORDER

(10 pcs) SCF250-050-D

(10 pcs) SCF250-050-D-N

ISO 11901 - 1	VDI 3003	B2 4006 (BMW)	075.90.55 (FCA)
PG23D (Mazda)	B8 3180 220 000 001(MB)	K 32 S (Nissan)	E24.54.815.G (PSA)
EM24.54.700 (Renault)	SES-K 5404e (Suzuki)	39D 878 (VW)	

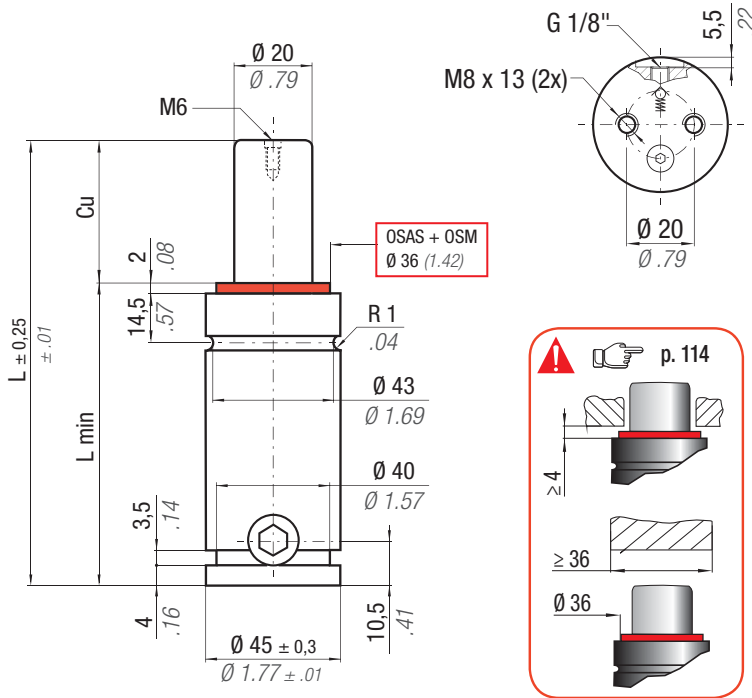

OSAS + OSM = OVER STROKE ACTIVE SAFETY + OVER STROKE MARKER

Il nuovo codice sarà fornito solo ad esaurimento del vecchio
 The new code will be supplied only when the old will be out of stock
 Der neue Kode wird geliefert nur wenn der alte nicht mehr im Lager ist
 Le nouveau code sera fourni uniquement lorsque le vieux stock sera écoulé
 El nuevo código será suministrado sólo cuando el viejo está fuera de stock
 O novo código irá ser fornecido apenas quando o antigo esgotar stock

easu MANIFOLD p. 211

* F_{1i} = Isothermal end force at 100% Cu p. 16
 ** F_{1p} = Polytrophic end force at 100% Cu



ACTIVE SAFETY



OSAS



USAS



OPAS

	$^{\circ}\text{F}$ 32 - 176	$^{\circ}\text{C}$ 0 - 80	ΔP $\pm 0,33\%/^{\circ}\text{C}$	P max 150 bar 2175 psi	P min 20 bar 290 psi	S 3,14 cm ² 0.487 in ²	SPM ~ 40 - 80 (at 20°C)	Max Speed 1,8 m/s	Maintenance kit 39BMS00500D
--	--------------------------------------	------------------------------------	---	-------------------------------------	-----------------------------------	---	--------------------------------------	-----------------------------	---------------------------------------

CODE PHASING OUT from 01/2014	NEW	Cu		L		L min		F0 Initial force		F _{1i} * End force *		F _{1p} ** End force **		V0		PED 2014/68/EU		
		mm	inch	mm	inch	mm	inch	daN	lb	daN	lb	daN	lb	cm ³	in ³	~Kg	~lb	✓
-	SC 500 - 010 - D	10	0.39	105	4.13	95	3.74			595	1338	673	1512	18,0	1.10	0,90	1.98	✓
SC 500 - 013 - B	SC 500 - 013 - D	12,7	0.50	110,4	4.35	97,7	3.85			611	1373	696	1565	20,0	1.22	1,00	2.20	✓
SC 500 - 025 - B	SC 500 - 025 - D	25	0.98	135	5.31	110	4.33			652	1466	759	1707	33,0	2.01	1,09	2.40	✓
SC 500 - 038 - B	SC 500 - 038 - D	38	1.50	161	6.34	123	4.84	470	1057	673	1513	792	1780	46,0	2.81	1,20	2.65	✓
SC 500 - 050 - B	SC 500 - 050 - D	50	1.97	185	7.28	135	5.31	$\pm 5\%$		685	1539	810	1820	58,0	3.54	1,29	2.84	✓
SC 500 - 063 - B	SC 500 - 063 - D	63,5	2.50	212	8.35	148,5	5.85	150 bar		693	1558	823	1850	72,0	4.39	1,38	3.04	✓
SC 500 - 080 - B	SC 500 - 080 - D	80	3.15	245	9.65	165	6.50	2175 psi		700	1573	834	1875	89,0	5.43	1,50	3.31	✓
SC 500 - 100 - B	SC 500 - 100 - D	100	3.94	285	11.22	185	7.28	+ 20 °C + 68 °F		706	1586	843	1895	109,0	6.65	1,64	3.62	✓
SC 500 - 125 - B	SC 500 - 125 - D	125	4.92	335	13.19	210	8.27			710	1597	850	1912	135,0	8.24	1,85	4.08	✓
SC 500 - 160 - B	SC 500 - 160 - D	160	6.30	405	15.94	245	9.65			715	1606	857	1927	170,0	10.37	2,10	4.63	✓
-	SC 500 - 200 - D	200	7.87	485	19.09	285	11.22			728	1637	878	1974	205,0	12.51	2,36	5.20	✓

SC SCF

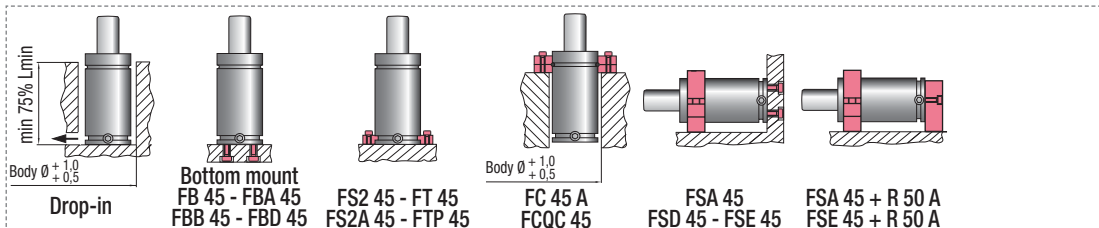

HOW TO ORDER

(10 pcs) SC 500-050-D
 (10 pcs) SC 500-050-D-N

SC 750

ISO 11901 - 1	VDI 3003	B2 4006 (BMW)	075.90.55 (FCA)
W-DX35-6203 (Ford)	PG23D (Mazda)	B8 3180 220 000 001(MB)	K 32 S (Nissan)
E24.54.815.G (PSA)	EM24.54.700 (Renault)	SES-K 5404e (Suzuki)	39D 878 (VW)



ACTIVE SAFETY



OSAS



USAS



OPAS

OSAS + OSM = OVER STROKE SAFETY + OVER STROKE MARKER

Il nuovo codice sarà fornito solo ad esaurimento del vecchio

The new code will be supplied only when the old will be out of stock

Der neue Kode wird geliefert nur wenn der alte nicht mehr im Lager ist

Le nouveau code sera fourni uniquement lorsque le vieux stock sera écoulé

El nuevo código será suministrado sólo cuando el viejo está fuera de stock

O novo código irá ser fornecido apenas quando o antigo esgotar stock

easu MANIFOLD p. 211

* F_{1i} =

Isothermal end force at 100% Cu p. 16

** F_{1p} =

Polytropic end force at 100% Cu p. 16

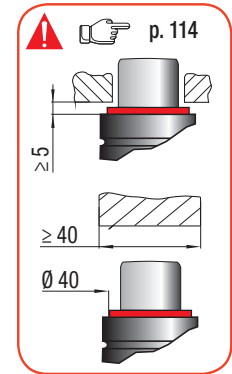
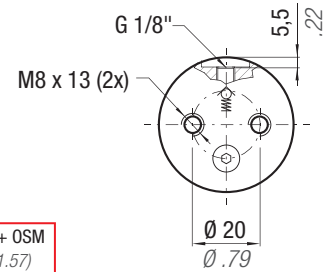
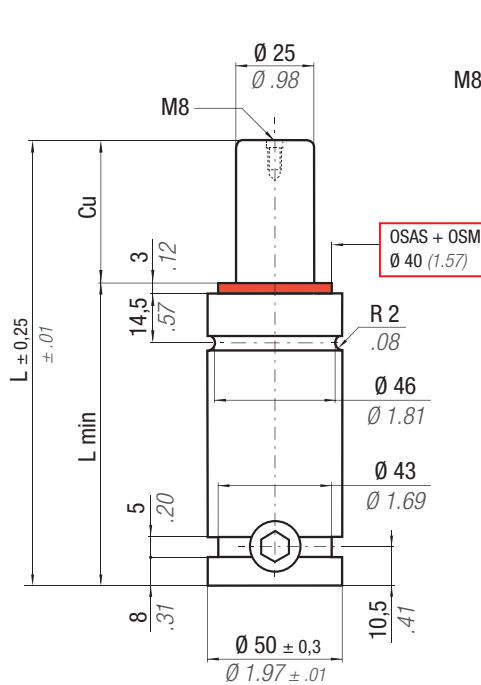

N ₂	°F 32 176	°C 0 80	ΔP ± 0,33 %/°C	P max 150 bar 2175 psi	P min 20 bar 290 psi	S 4,91 cm ² 0,761 in ²	SPM ~ 15 - 50 (at 20°C)	Max Speed 1,8 m/s	Maintenance kit 39BMSOC00750D
----------------	--------------	------------	---------------------------	------------------------------	----------------------------	--	-------------------------------	----------------------	----------------------------------

CODE PHASING OUT from 01/2014	NEW	Cu		L		L min		F ₀		F _{1i} *		F _{1p} **		V ₀		~Kg	~lb	PED 2014/68/EU
		mm	inch	mm	inch	mm	inch	daN	lb	daN	lb	daN	lb	cm ³	in ³			
SC 750 - 013 - B	SC 750 - 013 - D	12,7	0.50	120,4	4.74	107,7	4.24	740 ± 5%	1664	902	2028	1009	2269	40,0	2.44	1,24	2.73	✓
SC 750 - 025 - B	SC 750 - 025 - D	25	0.98	145	5.71	120	4.72			977	2197	1122	2523	58,0	3.54	1,34	2.95	✓
SC 750 - 038 - B	SC 750 - 038 - D	38	1.50	171	6.73	133	5.24			1023	2300	1192	2681	77,0	4.70	1,45	3.20	✓
SC 750 - 050 - B	SC 750 - 050 - D	50	1.97	195	7.68	145	5.71			1050	2362	1235	2777	95,0	5.80	1,54	3.40	✓
SC 750 - 063 - B	SC 750 - 063 - D	63,5	2.50	222	8.74	158,5	6.24			1072	2410	1269	2854	115,0	7.02	1,65	3.64	✓
-	SC 750 - 075 - D	75	2.95	245	9.65	170	6.69			1086	2441	1291	2902	132,0	8.05	1,75	3.86	✓
SC 750 - 080 - B	SC 750 - 080 - D	80	3.15	255	10.04	175	6.89			1091	2452	1299	2920	140,0	8.54	1,79	3.95	✓
-	SC 750 - 088 - D	88	3.46	270	10.63	182	7.17			1101	2475	1314	2954	150,0	9.15	1,85	4.08	✓
SC 750 - 100 - B	SC 750 - 100 - D	100	3.94	295	11.61	195	7.68			1107	2488	1324	2976	169,0	10.31	1,96	4.32	✓
-	SC 750 - 113 - D	113	4.45	320	12.60	207	8.15			1117	2511	1340	3012	188,0	11.47	2,06	4.54	✓
SC 750 - 125 - B	SC 750 - 125 - D	125	4.92	345	13.58	220	8.66			1121	2519	1346	3026	206,0	12.57	2,16	4.76	✓
-	SC 750 - 138 - D	138	5.43	370	14.57	232	9.13			1131	2543	1363	3064	224,0	13.66	2,27	5.00	✓
-	SC 750 - 150 - D	150	5.91	395	15.55	245	9.65			1140	2563	1378	3098	239,0	14.58	2,39	5.27	✓
SC 750 - 160 - B	SC 750 - 160 - D	160	6.30	415	16.34	255	10.04			1149	2582	1391	3126	252,0	15.37	2,49	5.49	✓
-	SC 750 - 175 - D	175	6.89	445	17.52	270	10.63	1160	2608	1408	3165	271,0	16.53	2,64	5.82	✓		
SC 750 - 200 - B	SC 750 - 200 - D	200	7.87	495	19.49	295	11.61	1175	2642	1434	3223	302,0	18.42	2,89	6.37	✓		
-	SC 750 - 225 - D	225	8.86	545	21.46	320	12.60	1188	2671	1455	3271	334,0	20.37	3,13	6.90	✓		
SC 750 - 250 - B	SC 750 - 250 - D	250	9.84	595	23.43	345	13.58	1199	2696	1472	3310	365,0	22.27	3,32	7.32	✓		
-	SC 750 - 275 - D	275	10.83	645	25.39	370	14.57	1208	2716	1488	3345	396,0	24.16	3,63	8.00	✓		
SC 750 - 300 - B	SC 750 - 300 - D	300	11.81	695	27.36	395	15.55	1216	2735	1501	3374	428,0	26.11	3,88	8.55	✓		

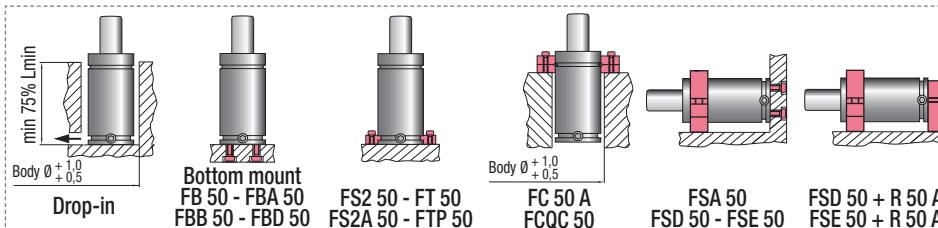

HOW TO ORDER

(10 pcs) SC 750-050-D
(10 pcs) SC 750-050-D-N

ISO 11901 - 1	VDI 3003	B2 4006 (BMW)	075.90.55 (FCA)
W-DX35-6203 (Ford)	PG23D (Mazda)	B8 3180 220 000 001(MB)	K 32 S (Nissan)
E24.54.815.G (PSA)	EM24.54.700 (Renault)	SES-K 5404e (Suzuki)	39D 878 (VW)

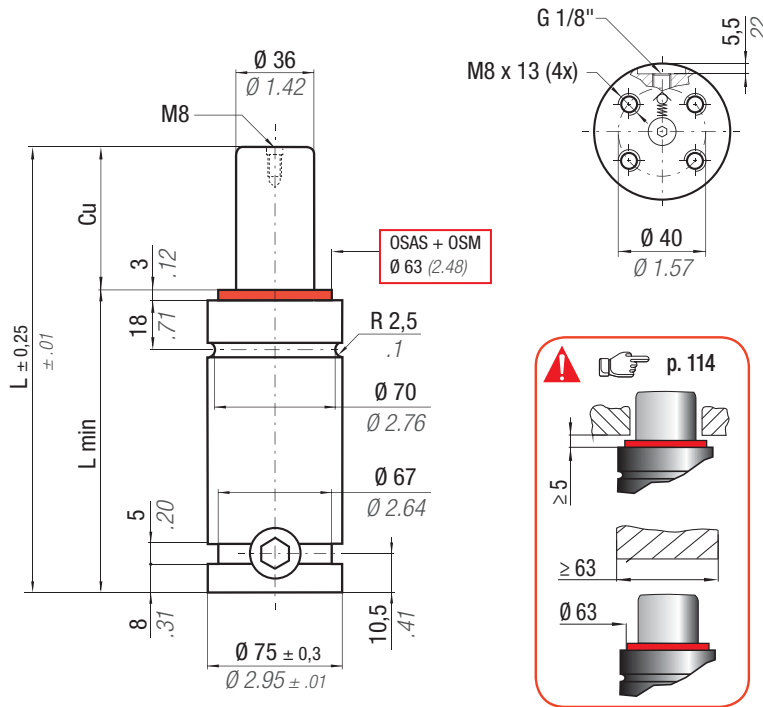

OSAS + OSM = OVER STROKE ACTIVE SAFETY + OVER STROKE MARKER

Il nuovo codice sarà fornito solo ad esaurimento del vecchio
 The new code will be supplied only when the old will be out of stock
 Der neue Kode wird geliefert nur wenn der alte nicht mehr im Lager ist
 Le nouveau code sera fourni uniquement lorsque le vieux stock sera écoulé
 El nuevo código será suministrado sólo cuando el viejo está fuera de stock
 O novo código irá ser fornecido apenas quando o antigo esgotar stock

easu MANIFOLD p. 211

* F_{1i} = Isothermal end force at 100% Cu p. 16
 ** F_{1p} = Polytrophic end force at 100% Cu



ACTIVE SAFETY



OSAS



USAS



OPAS

	$^{\circ}\text{F}$ 32 - 176	$^{\circ}\text{C}$ 0 - 80	ΔP $\pm 0,33\% / ^{\circ}\text{C}$	P max 150 bar 2175 psi	P min 20 bar 290 psi	S 10,18 cm ² 1.578 in ²	SPM ~ 15 - 50 (at 20°C)	Max Speed 1,8 m/s	Maintenance kit 39BMSCO1500D Cu 13 ÷ 80 39BMSCO1500DH Cu 88 ÷ 300
--	--------------------------------------	------------------------------------	---	-------------------------------------	-----------------------------------	--	--------------------------------------	-----------------------------	--

CODE PHASING OUT from 01/2014	NEW	Cu		L		L min		F0 Initial force		F _{1i} *		F _{1p} **		V0		PED 2014/68/EU		
		mm	inch	mm	inch	mm	inch	daN	lb	daN	lb	daN	lb	cm ³	in ³		~Kg	~lb
-	SC 1500 - 013 - D	13	0.51	135	5.31	122	4.80			1819	4089	2016	4532	97,0	5.92	3,26	7.19	✓
SC 1500 - 025 - B	SC 1500 - 025 - D	25	0.98	160	6.30	135	5.31			1925	4329	2174	4888	144,0	8.78	3,47	7.65	✓
SC 1500 - 038 - B	SC 1500 - 038 - D	38	1.50	186	7.32	148	5.83			2000	4496	2287	5141	191,0	11.65	3,67	8.09	✓
SC 1500 - 050 - B	SC 1500 - 050 - D	50	1.97	210	8.27	160	6.30			2045	4596	2355	5294	234,0	14.27	3,85	8.49	✓
SC 1500 - 063 - B	SC 1500 - 063 - D	63,5	2.50	237	9.33	173,5	6.83			2080	4675	2409	5415	283,0	17.26	4,05	8.93	✓
-	SC 1500 - 075 - D	75	2.95	260	10.24	185	7.28			2102	4725	2443	5492	324,0	19.76	4,23	9.33	✓
SC 1500 - 080 - B	SC 1500 - 080 - D	80	3.15	270	10.63	190	7.48			2110	4743	2455	5519	342,0	20.86	4,30	9.48	✓
-	SC 1500 - 088 - D	88	3.46	285	11.22	197	7.76			2130	4788	2486	5589	367,0	22.39	4,42	9.74	✓
SC 1500 - 100 - B	SC 1500 - 100 - D	100	3.94	310	12.20	210	8.27	1530	3440 ± 5%	2136	4802	2495	5609	414,0	25.25	4,60	10.14	✓
-	SC 1500 - 113 - D	113	4.45	335	13.19	222	8.74			2151	4836	2520	5665	459,0	28.00	4,78	10.54	✓
SC 1500 - 125 - B	SC 1500 - 125 - D	125	4.92	360	14.17	235	9.25	150 bar	2175 psi	2158	4851	2529	5685	505,0	30.81	4,97	10.96	✓
-	SC 1500 - 138 - D	138	5.43	385	15.16	247	9.72			2169	4876	2548	5728	550,0	33.55	5,16	11.38	✓
-	SC 1500 - 150 - D	150	5.91	410	16.14	260	10.24			2173	4885	2554	5742	595,0	36.30	5,35	11.79	✓
SC 1500 - 160 - B	SC 1500 - 160 - D	160	6.30	430	16.93	270	10.63	+ 20 °C +68 °F		2178	4896	2562	5760	631,0	38.49	5,50	12.13	✓
-	SC 1500 - 175 - D	175	6.89	460	18.11	285	11.22			2185	4912	2572	5782	685,0	41.79	5,73	12.63	✓
SC 1500 - 200 - B	SC 1500 - 200 - D	200	7.87	510	20.08	310	12.20			2198	4941	2592	5828	772,0	47.09	6,13	13.51	✓
-	SC 1500 - 225 - D	225	8.86	560	22.05	335	13.19			2219	4989	2625	5901	850,0	51.85	6,60	14.55	✓
SC 1500 - 250 - B	SC 1500 - 250 - D	250	9.84	610	24.02	360	14.17			2236	5027	2652	5962	928,0	56.61	7,08	15.61	✓
-	SC 1500 - 275 - D	275	10.83	660	22.05	385	15.16			2251	5060	2676	6016	1006,0	61.37	7,55	16.64	✓
SC 1500 - 300 - B	SC 1500 - 300 - D	300	11.81	710	27.95	410	16.14			2264	5089	2696	6061	1084,0	66.12	8,02	17.68	✓

SC SCF

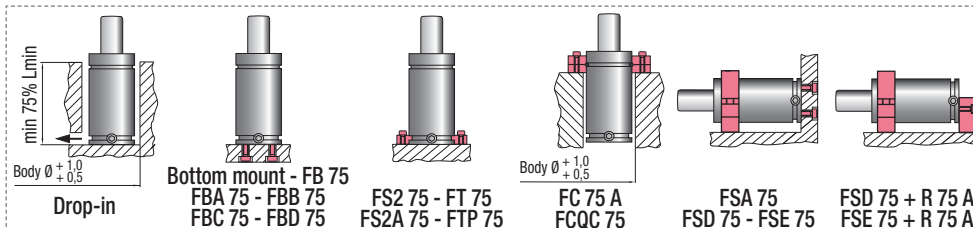

HOW TO ORDER

(10 pcs) SC 1500-050-D
 (10 pcs) SC 1500-050-D-N

SC 3000

ISO 11901 - 1	VDI 3003	B2 4006 (BMW)	075.90.55 (FCA)
W-DX35-6203 (Ford)	PG23D (Mazda)	B8 3180 220 000 001(MB)	K 32 S (Nissan)
E24.54.815.G (PSA)	EM24.54.700 (Renault)	SES-K 5404e (Suzuki)	39D 878 (VW)



OSAS + OSM = OVER STROKE ACTIVE SAFETY + OVER STROKE MARKER

ACTIVE SAFETY



OSAS



USAS



OPAS

Il nuovo codice sarà fornito solo ad esaurimento del vecchio
 The new code will be supplied only when the old will be out of stock
 Der neue Kode wird geliefert nur wenn der alte nicht mehr im Lager ist
 Le nouveau code sera fourni uniquement lorsque le vieux stock sera écoulé
 El nuevo código será suministrado sólo cuando el viejo está fuera de stock
 O novo código irá ser fornecido apenas quando o antigo esgotar stock

easu MANIFOLD p. 211

* F_{1i} = Isothermal end force at 100% Cu p. 16
 ** F_{1p} = Polytrophic end force at 100% Cu

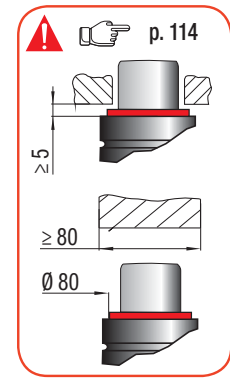
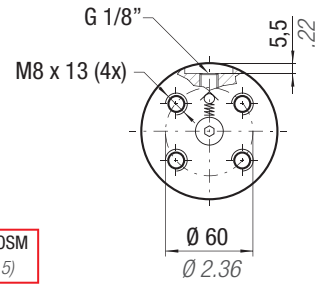
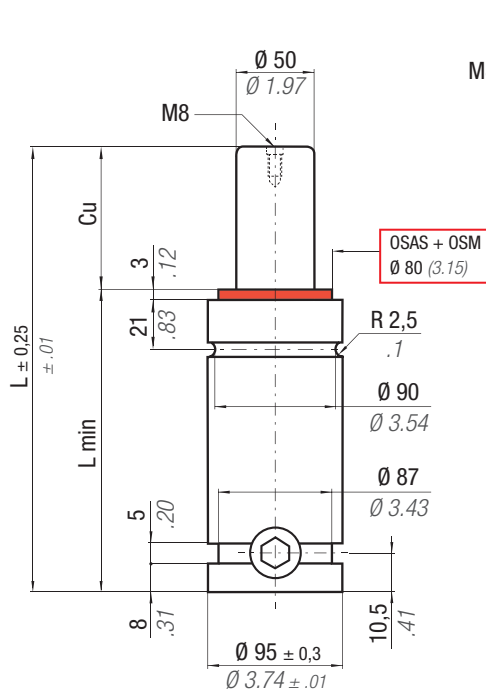

N ₂	°F 32 176	°C 0 80	ΔP ± 0,33 %/°C	P max 150 bar 2175 psi	P min 20 bar 290 psi	S 19,63 cm ² 3.043 in ²	SPM ~ 15 - 50 (at 20°C)	Max Speed 1,8 m/s	Maintenance kit 39BMSCO3000D Cu 13 ÷ 80 39BMSCO3000DH Cu 88 ÷ 300
----------------	--------------	------------	---------------------------	------------------------------	----------------------------	---	-------------------------------	----------------------	---

CODE PHASING OUT from 01/2014	NEW	Cu		L		L min		F ₀		F _{1i} *		F _{1p} **		V ₀		PED 2014/68/EU		
		mm	inch	mm	inch	mm	inch	daN	lb	daN	lb	daN	lb	cm ³	in ³		~Kg	~lb
-	SC 3000 - 013 - D	13	0.51	145	5.71	132	5.20	2945 6621 ± 5%	150 bar 2175 psi	3528	7931	3917	8806	181,0	11.04	5,57	12,28	✓
SC 3000 - 025 - B	SC 3000 - 025 - D	25	0.98	170	6.69	145	5.71			3775	8487	4286	9636	261,0	15.92	5,90	13,01	✓
SC 3000 - 038 - B	SC 3000 - 038 - D	38	1.50	196	7.72	158	6.22			3955	8891	4559	10250	340,0	20.74	6,21	13,69	✓
SC 3000 - 050 - B	SC 3000 - 050 - D	50	1.97	220	8.66	170	6.69			4067	9143	4732	10638	413,0	25.19	6,50	14,33	✓
SC 3000 - 063 - B	SC 3000 - 063 - D	63,5	2.50	247	9.72	183,5	7.22			4158	9347	4873	10954	496,0	30.26	6,83	15,06	✓
-	SC 3000 - 075 - D	75	2.95	270	10.63	195	7.68			4216	9478	4964	11160	566,0	34.53	7,10	15,65	✓
SC 3000 - 080 - B	SC 3000 - 080 - D	80	3.15	280	11.02	200	7.87			4238	9527	4997	11234	596,0	36.36	7,22	15,92	✓
-	SC 3000 - 088 - D	88	3.46	295	11.61	207	8.15			4277	9615	5059	11373	642,0	39.16	7,41	16,34	✓
SC 3000 - 100 - B	SC 3000 - 100 - D	100	3.94	320	12.60	220	8.66			4307	9683	5105	11476	718,0	43.80	7,67	16,91	✓
-	SC 3000 - 113 - D	113	4.45	345	13.58	232	9.13			4348	9775	5171	11625	795,0	48.50	7,97	17,57	✓
SC 3000 - 125 - B	SC 3000 - 125 - D	125	4.92	370	14.57	245	9.65			4367	9817	5201	11692	871,0	53.13	8,27	18,23	✓
-	SC 3000 - 138 - D	138	5.43	395	15.55	257	10.12			4398	9887	5250	11802	947,0	57.77	8,57	18,89	✓
-	SC 3000 - 150 - D	150	5.91	420	16.54	270	10.63			4411	9916	5270	11847	1023,0	62.40	8,87	19,56	✓
SC 3000 - 160 - B	SC 3000 - 160 - D	160	6.30	440	17.32	280	11.02			4425	9948	5292	11897	1085,0	66.19	9,11	20,08	✓
-	SC 3000 - 175 - D	175	6.89	470	18.50	295	11.61	4443	9988	5322	11964	1176,0	71.74	9,47	20,88	✓		
SC 3000 - 200 - B	SC 3000 - 200 - D	200	7.87	520	20.47	320	12.60	4469	10047	5362	12055	1329,0	81.07	10,08	22,22	✓		
-	SC 3000 - 225 - D	225	8.86	570	22.44	345	13.58	4489	10092	5395	12128	1481,0	90.34	10,68	23,55	✓		
SC 3000 - 250 - B	SC 3000 - 250 - D	250	9.84	620	24.41	370	14.57	4506	10130	5422	12189	1634,0	99.67	11,28	24,87	✓		
-	SC 3000 - 275 - D	275	10.83	670	26.38	395	15.55	4520	10161	5444	12239	1786,0	108.95	11,88	26,19	✓		
SC 3000 - 300 - B	SC 3000 - 300 - D	300	11.81	720	28.35	420	16.54	4532	10188	5463	12282	1939,0	118.28	12,49	27,54	✓		

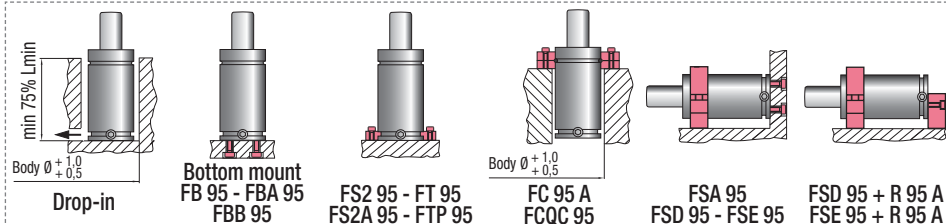

HOW TO ORDER

(10 pcs) SC 3000-050-D
 (10 pcs) SC 3000-050-D-N

ISO 11901 - 1	075.90.55 (FCA)	W-DX35-6203 (Ford)	EM24.54.700 (Renault)
PG23D (Mazda)	VDI 3003	B8 3180 220 000 001(MB)	39D 878 (VW)
SES-K 5404e (Suzuki)	B2 4006 (BMW)	E24.54.815.G (PSA)	K 32 S (Nissan)

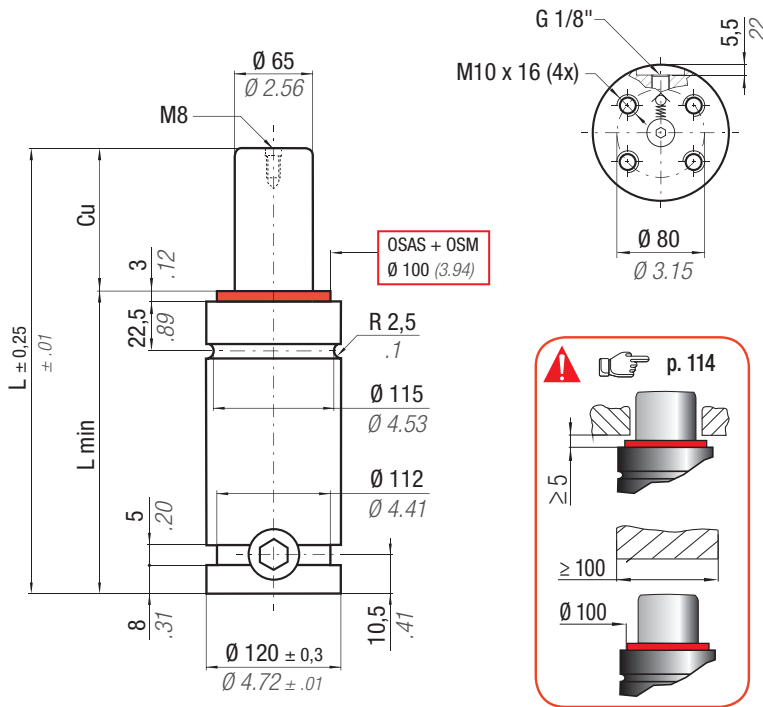

OSAS + OSM = OVER STROKE ACTIVE SAFETY + OVER STROKE MARKER

Il nuovo codice sarà fornito solo ad esaurimento del vecchio
 The new code will be supplied only when the old will be out of stock
 Der neue Kode wird geliefert nur wenn der alte nicht mehr im Lager ist
 Le nouveau code sera fourni uniquement lorsque le vieux stock sera épuisé
 El nuevo código será suministrado sólo cuando el viejo está fuera de stock
 O novo código irá ser fornecido apenas quando o antigo esgotar stock

easu MANIFOLD p. 211

* F_{1i} = Isothermal end force at 100% Cu p. 16
 ** F_{1p} = Polytrophic end force at 100% Cu



ACTIVE SAFETY



OSAS



USAS



OPAS

	$^{\circ}\text{F}$ 32 - 176	$^{\circ}\text{C}$ 0 - 80	ΔP ± 0,33 %/°C	P max 150 bar 2175 psi	P min 20 bar 290 psi	S 33,18 cm ² 5.143 in ²	SPM ~ 15 - 50 (at 20°C)	Max Speed 1,8 m/s	Maintenance kit 39BMS05000D Cu 25 ÷ 80 39BMS05000DH Cu 88 ÷ 300
--	--------------------------------------	------------------------------------	---------------------------------	-------------------------------------	-----------------------------------	--	--------------------------------------	-----------------------------	--

CODE PHASING OUT from 01/2014	NEW	Cu		L		L min		F0 Initial force		F _{1i} * End force *		F _{1p} ** End force **		V0		PED 2014/68/EU		
		mm	inch	mm	inch	mm	inch	daN	lb	daN	lb	daN	lb	cm ³	in ³		~Kg	~lb
SC 5000 - 025 - B	SC 5000 - 025 - D	25	0.98	190	7.48	165	6.50	4980 ± 5%	11195	6316	14199	7148	16068	457,0	27.88	10,94	24.12	✓
SC 5000 - 038 - B	SC 5000 - 038 - D	38	1.50	216	8.50	178	7.01			6652	14955	7657	17214	583,0	35.56	11,46	25.26	✓
SC 5000 - 050 - B	SC 5000 - 050 - D	50	1.97	240	9.45	190	7.48			6872	15448	7994	17972	699,0	42.64	11,94	26.32	✓
SC 5000 - 063 - B	SC 5000 - 063 - D	63,5	2.50	267	10.51	203.5	8.01			7077	15910	8313	18688	823,0	50.20	12,56	27.69	✓
-	SC 5000 - 075 - D	75	2.95	290	11.42	215	8.46			7176	16132	8467	19035	941,0	57.40	12,94	28.53	✓
SC 5000 - 080 - B	SC 5000 - 080 - D	80	3.15	300	11.81	220	8.66			7221	16232	8537	19193	989,0	60.33	13,15	28.99	✓
-	SC 5000 - 088 - D	88	3.46	315	12.40	227	8.94			7300	16411	8662	19473	1061,0	64.72	13,39	29.52	✓
SC 5000 - 100 - B	SC 5000 - 100 - D	100	3.94	340	13.39	240	9.45			7367	16562	8768	19712	1182,0	72.10	13,89	30.62	✓
-	SC 5000 - 113 - D	113	4.45	365	14.37	252	9.92			7454	16757	8906	20021	1303,0	79.48	14,40	31.75	✓
SC 5000 - 125 - B	SC 5000 - 125 - D	125	4.92	390	15.35	265	10.43			7499	16858	8977	20181	1424,0	86.86	14,90	32.85	✓
-	SC 5000 - 138 - D	138	5.43	415	16.34	277	10.91	7564	17005	9081	20415	1545,0	94.25	15,40	33.95	✓		
-	SC 5000 - 150 - D	150	5.91	440	17.32	290	11.42	7595	17074	9130	20525	1665,0	101.57	15,90	35.05	✓		
SC 5000 - 160 - B	SC 5000 - 160 - D	160	6.30	460	18.11	300	11.81	7627	17145	9181	20639	1762,0	107.48	16,30	35.94	✓		
-	SC 5000 - 175 - D	175	6.89	490	19.29	315	12.40	7668	17238	9247	20788	1907,0	116.33	16,90	37.26	✓		
SC 5000 - 200 - B	SC 5000 - 200 - D	200	7.87	540	21.26	340	13.39	7726	17369	9340	20997	2148,0	131.03	17,91	39.48	✓		
-	SC 5000 - 225 - D	225	8.86	590	23.23	365	14.37	7773	17474	9415	21166	2390,0	145.79	18,91	41.69	✓		
SC 5000 - 250 - B	SC 5000 - 250 - D	250	9.84	640	25.20	390	15.35	7811	17560	9477	21305	2632,0	160.55	19,91	43.89	✓		
-	SC 5000 - 275 - D	275	10.83	690	27.17	415	16.34	7843	17632	9529	21422	2873,0	175.25	20,92	46.12	✓		
SC 5000 - 300 - B	SC 5000 - 300 - D	300	11.81	740	29.13	440	17.32	7871	17694	9573	21521	3115,0	190.02	21,92	48.33	✓		

SC
SCF

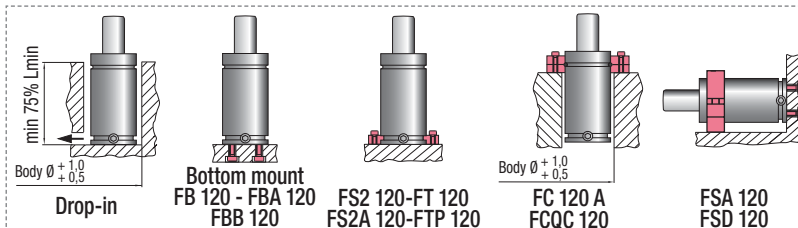

HOW TO ORDER

(10 pcs) SC 5000-050-D
 (10 pcs) SC 5000-050-D-N

ISO 11901 - 1	VDI 3003	B2 4006 (BMW)	075.90.55 (FCA)
W-DX35-6203 (Ford)	PG23D (Mazda)	B8 3180 220 000 001(MB)	E24.54.815.G (PSA)
EM24.54.700 (Renault)	39D 878 (VW)		



ACTIVE SAFETY



OSAS



USAS



OPAS

OSAS + OSM = OVER STROKE ACTIVE SAFETY + OVER STROKE MARKER

Il nuovo codice sarà fornito solo ad esaurimento del vecchio
 The new code will be supplied only when the old will be out of stock
 Der neue Kode wird geliefert nur wenn der alte nicht mehr im Lager ist
 Le nouveau code sera fourni uniquement lorsque le vieux stock sera écoulé
 El nuevo código será suministrado sólo cuando el viejo está fuera de stock
 O novo código irá ser fornecido apenas quando o antigo esgotar stock

easu MANIFOLD p. 211

* F_{1i} = Isothermal end force at 100% Cu p. 16
 ** F_{1p} = Polytropic end force at 100% Cu

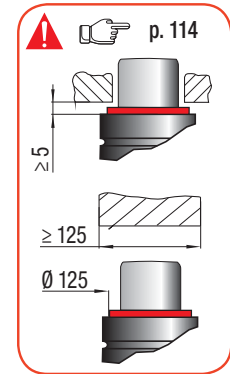
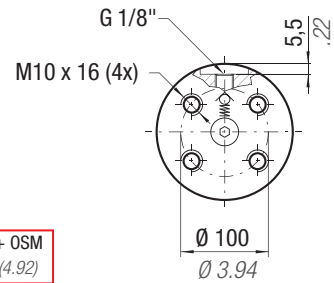
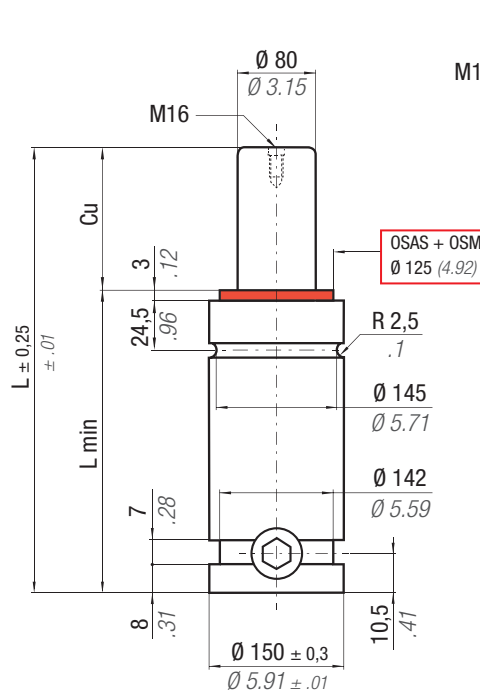

N ₂	°F 32 176	°C 0 80	ΔP ± 0,33 %/°C	P max 150 bar 2175 psi	P min 20 bar 290 psi	S 50,27 cm ² 7.792 in ²	SPM ~ 15 - 50 (at 20°C)	Max Speed 1,8 m/s	Maintenance kit 39BMSOC07500D Cu 25 ÷ 80 39BMSOC07500DH Cu 88 ÷ 300
----------------	--------------	------------	---------------------------	------------------------------	----------------------------	---	-------------------------------	----------------------	---

CODE PHASING OUT from 01/2014	NEW	Cu		L		L min		F ₀ Initial force		F _{1i} * End force *		F _{1p} ** End force **		V ₀		~Kg ~lb	PED 2014/68/EU								
		mm	inch	mm	inch	mm	inch	daN	lb	daN	lb	daN	lb	cm ³	in ³										
SC 7500 - 025 - B	SC 7500 - 025 - D	25	0.98	205	8.07	180	7.09	7540 ± 5% 16950 150 bar 2175 psi + 20 °C +68 °F	9330	20975	10472	23543	767,0	46.79	18,71	41.25	✓								
SC 7500 - 038 - B	SC 7500 - 038 - D	38	1.50	231	9.09	193	7.60										9809	22052	11192	25161	963,0	58.74	19,50	42.99	✓
SC 7500 - 050 - B	SC 7500 - 050 - D	50	1.97	255	10.04	205	8.07										10129	22771	11679	26255	1144,0	69.78	20,24	44.62	✓
SC 7500 - 063 - B	SC 7500 - 063 - D	63,5	2.50	282	11.10	218,5	8.60										10400	23380	12095	27191	1348,0	82.23	21,06	46.43	✓
-	SC 7500 - 075 - D	75	2.95	305	12.1	230	9.06										10581	23787	12375	27820	1522,0	92.84	21,76	47.97	✓
SC 7500 - 080 - B	SC 7500 - 080 - D	80	3.15	315	12.40	235	9.25										10648	23938	12480	28057	1597,0	97.42	22,07	48.66	✓
-	SC 7500 - 088 - D	88	3.46	330	12.99	242	9.53										10778	24230	12682	28510	1706,0	104.07	22,45	49.49	✓
SC 7500 - 100 - B	SC 7500 - 100 - D	100	3.94	355	13.98	255	10.04										10871	24439	12828	28838	1899,0	115.84	23,23	51.21	✓
-	SC 7500 - 113 - D	113	4.45	380	14.96	267	10.51										11013	24758	13051	29340	2083,0	127.06	23,98	52.87	✓
SC 7500 - 125 - B	SC 7500 - 125 - D	125	4.92	405	15.94	280	11.02										11073	24893	13146	29553	2276,0	138.84	24,76	54.59	✓
-	SC 7500 - 138 - D	138	5.43	430	16.93	292	11.50										11182	25138	13318	29940	2460,0	150.06	25,51	56.24	✓
-	SC 7500 - 150 - D	150	5.91	455	17.91	305	12.1										11222	25228	13382	30084	2654,0	161.89	26,28	57.94	✓
SC 7500 - 160 - B	SC 7500 - 160 - D	160	6.30	475	18.70	315	12.40										11272	25340	13459	30258	2805,0	171.11	26,90	59.30	✓
-	SC 7500 - 175 - D	175	6.89	505	19.88	330	12.99										11337	25487	13563	30491	3031,0	184.89	27,81	61.31	✓
SC 7500 - 200 - B	SC 7500 - 200 - D	200	7.87	555	21.85	355	13.98										11427	25689	13707	30815	3409,0	207.95	29,34	64.68	✓
-	SC 7500 - 225 - D	225	8.86	605	23.82	380	14.96										11501	25855	13824	31078	3786,0	230.95	30,87	68.06	✓
SC 7500 - 250 - B	SC 7500 - 250 - D	250	9.84	655	25.79	405	15.94										11562	25992	13921	31296	4164,0	254.00	32,39	71.41	✓
-	SC 7500 - 275 - D	275	10.83	705	27.76	430	16.93										11613	26107	14003	31480	4541,0	277.00	33,92	74.78	✓
SC 7500 - 300 - B	SC 7500 - 300 - D	300	11.81	755	29.72	455	17.91										11657	26206	14073	31637	4919,0	300.06	35,45	78.15	✓

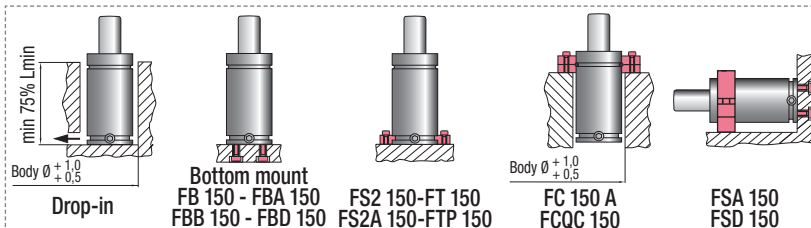

HOW TO ORDER

(10 pcs) SC 7500-050-D
 (10 pcs) SC 7500-050-D-N

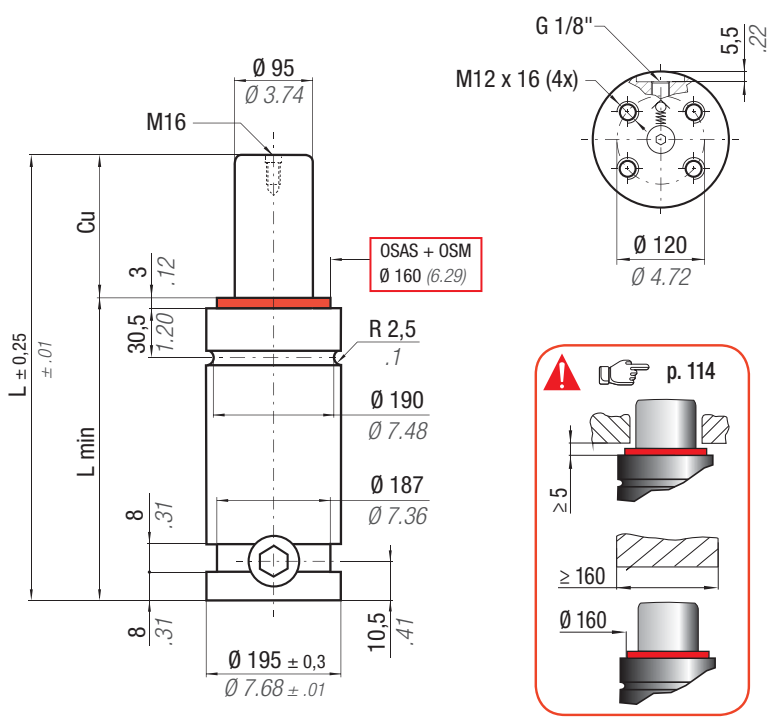

OSAS + OSM = OVER STROKE ACTIVE SAFETY + OVER STROKE SAFETY MARKER

Il nuovo codice sarà fornito solo ad esaurimento del vecchio
 The new code will be supplied only when the old will be out of stock
 Der neue Kode wird geliefert nur wenn der alte nicht mehr im Lager ist
 Le nouveau code sera fourni uniquement lorsque le vieux stock sera écoulé
 El nuevo código será suministrado sólo cuando el viejo está fuera de stock
 O novo código irá ser fornecido apenas quando o antigo esgotar stock

easu MANIFOLD p. 211

* F_{1i} = Isothermal end force at 100% Cu p. 16
 ** F_{1p} = Polytrophic end force at 100% Cu



	$^{\circ}\text{F}$ 32 - 176	$^{\circ}\text{C}$ 0 - 80	ΔP $\pm 0,33\%/^{\circ}\text{C}$	P max 150 bar 2175 psi	P min 20 bar 290 psi	S 70,88 cm ² 10.986 in ²	SPM ~ 15 - 50 (at 20°C)	Max Speed 1,8 m/s	Maintenance kit 39BMSK10000D
--	--------------------------------------	------------------------------------	---	-------------------------------------	-----------------------------------	---	--------------------------------------	-----------------------------	--

CODE PHASING OUT from 01/2014	NEW	Cu		L		L min		F0 Initial force		F1i * End force *		F1p ** End force **		V0		PED 2014/68/EU		
		mm	inch	mm	inch	mm	inch	daN	lb	daN	lb	daN	lb	cm ³	in ³	~Kg	~lb	✓
SC 10000 - 025 - C	SC 10000 - 025 - D	25	0.98	210	8.27	185	7.28	10600 ± 5%	23830	12892	28981	14373	32311	1186,0	72.35	33,73	74.36	✓
SC 10000 - 038 - C	SC 10000 - 038 - D	38	1.50	236	9.29	198	7.80			13463	30267	15225	34228	1497,0	91.32	35,08	77.34	✓
SC 10000 - 050 - C	SC 10000 - 050 - D	50	1.97	260	10.24	210	8.27			13838	31108	15790	35497	1784,0	108.82	36,32	80.07	✓
SC 10000 - 063 - C	SC 10000 - 063 - D	63,5	2.50	287	11.30	223,5	8.80			14151	31812	16266	36567	2108,0	128.59	37,72	83.16	✓
SC 10000 - 080 - C	SC 10000 - 080 - D	80	3.15	320	12.60	240	9.45			14434	32450	16700	37543	2503,0	152.68	39,44	86.95	✓
SC 10000 - 100 - C	SC 10000 - 100 - D	100	3.94	360	14.17	260	10.24			14686	33015	17087	38414	2982,0	181.90	41,51	91.51	✓
SC 10000 - 125 - C	SC 10000 - 125 - D	125	4.92	410	16.14	285	11.22			14912	33524	17438	39202	3581,0	218.44	44,11	97.25	✓
SC 10000 - 160 - C	SC 10000 - 160 - D	160	6.30	480	18.90	320	12.60			15132	34018	17780	39971	4419,0	269.56	47,74	105.25	✓
SC 10000 - 200 - C	SC 10000 - 200 - D	200	7.87	560	22.05	360	14.17			15345	34498	18114	40722	5343,0	325.92	52,17	115.02	✓
SC 10000 - 250 - C	SC 10000 - 250 - D	250	9.84	660	25.98	410	16.14			15696	35286	18665	41961	6348,0	387.23	58,87	129.79	✓
SC 10000 - 300 - C	SC 10000 - 300 - D	300	11.81	760	29.92	460	18.11	15960	35879	19083	42901	7354,0	448.59	65,57	144.56	✓		

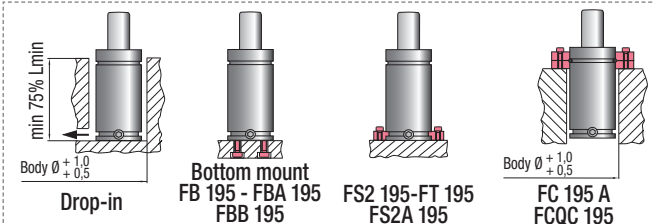

HOW TO ORDER
 (10 pcs) SC 10000-050-D
 (10 pcs) SC 10000-050-D-N

ISO	VDI	BMW
FCA	VW	

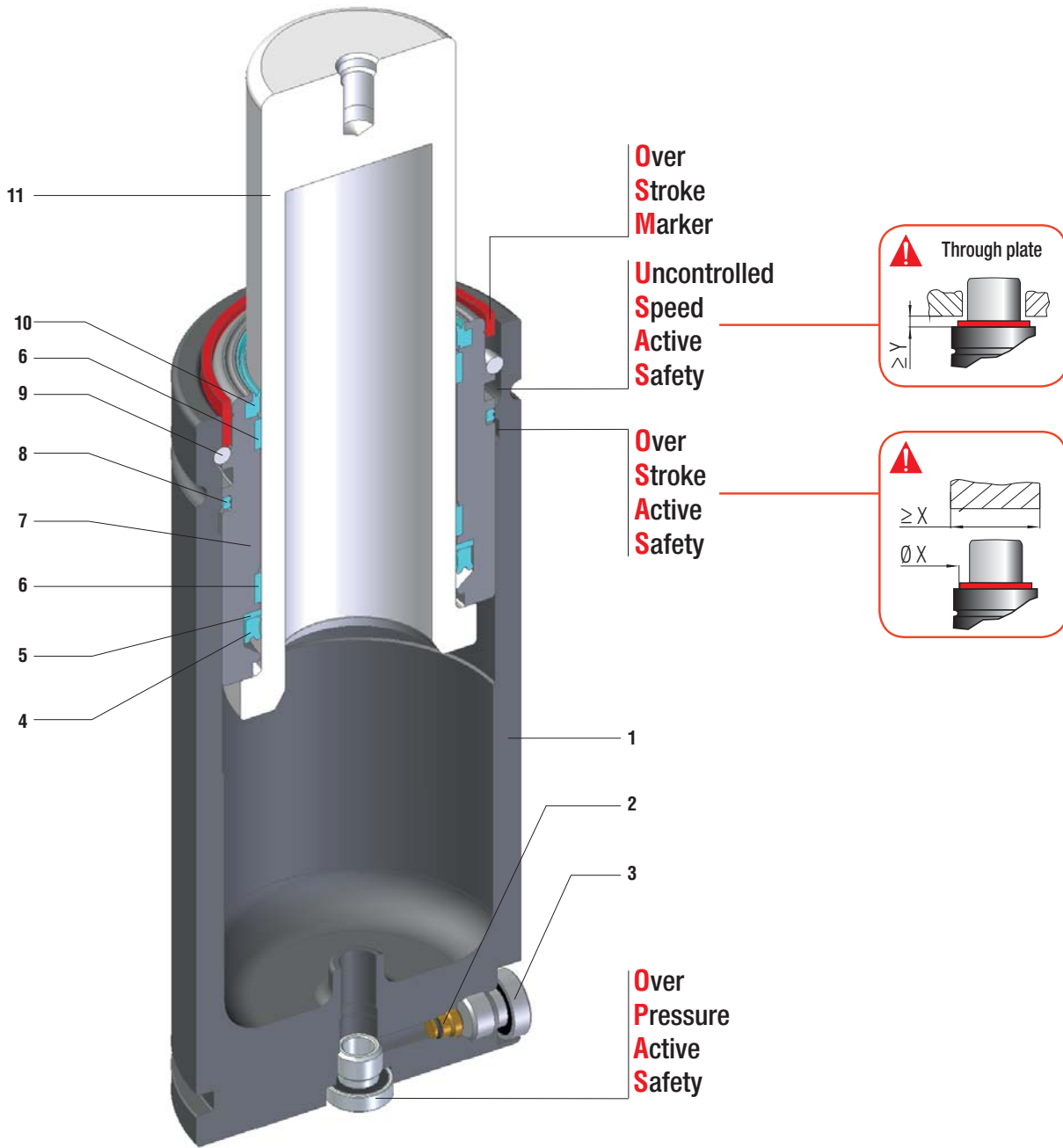

ISO standard, forza potenziata - ISO standard, high force - ISO Standard, erhöhte Kraft
 Standard ISO, force majorée - ISO standard, fuerza potenciada - Norma ISO, forța permitida

SEALING	ROD SEAL
DESIGN	BUSH - BODY DESIGN

1	Body	5	Back-up ring	9	Retaining ring
2	Valve	6	Guide ring	10	Rod wiper
3	Plug	7	Bush	11	Rod (nitrited superfinished)
4	Rod seal	8	Dual ring seal		

RANGE CHART

Model	Body Ø		Stroke Cu		Initial force F0					
	mm	inch	mm	inch	daN	lb				
H 300	32	1.26	10 - 125	0.39 - 4.92	300	674	✓	✓	✓	-
H 500	38	1.50	10 - 125	0.39 - 4.92	470	1057	✓	✓	✓	-
HF 500	M 38 X 1,5	M 38 X 1,5	10 - 125	0.39 - 4.92	470	1057	✓	✓	✓	-
H 700	45	1.77	10 - 160	0.51 - 6.30	680	1529	✓	✓	✓	-
H 1000	50	1.97	13 - 300	0.51 - 11.81	920	2383	✓	✓	✓	-
H 1500	63	2.48	13 - 300	0.51 - 11.81	1530	3440	✓	✓	✓	-
H 2400	75	2.95	25 - 300	0.98 - 11.81	2385	5362	✓	✓	✓	-
H 4200	95	3.74	25 - 300	0.98 - 11.81	4240	9532	✓	✓	✓	-
H 6600	120	4.72	25 - 300	0.98 - 11.81	6630	14905	✓	✓	✓	-
H 9500	150	5.91	25 - 300	0.98 - 11.81	9540	21446	✓	✓	✓	-
H 18500	195	7.68	25 - 300	0.98 - 11.81	18400	41365	✓	✓	✓	-

HOW TO ORDER

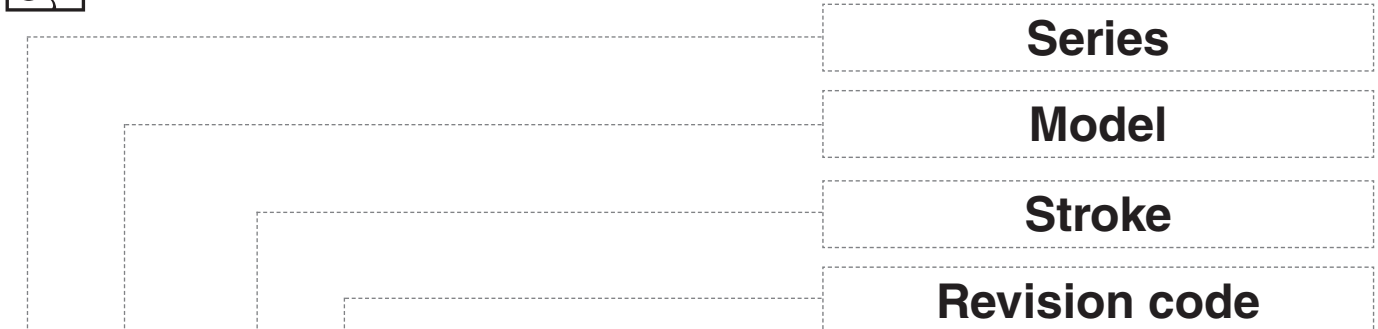

H 2400-050-C - N - E

- IT** Codice cilindro autonomo
- EN** Self-contained cylinder code
- DE** Kode des eingeständigen Gdf.
- FR** Code du cylindre autonome
- ES** Código del cilindro autónomo
- PT** Código do cilindro autónomo

- IT** Collegabile con tubi, cilindro fornito scarico e senza valvola unidirezionale
- EN** Linkable with hoses, cylinder supplied without pressure and oneway valve
- DE** Anschlussfähig mit Leitungen, Gdf. geliefert ohne Druck und RückschlagVentil
- FR** Connectable avec tubes, ressort fourni sans pression ni valve unidirectionelle
- ES** Connectable con tubos, cilindro suministrado sin presión y sin válvula unidireccional
- PT** Acompláveis com tubos, cilindro fornecidos sem pressão e sem válvula unidireccional

- IT** Collegabile EASY MANIFOLD, fornito scarico + guarnizione di collegamento
- EN** Linkable EASY MANIFOLD, supplied without pressure + connecting seal
- DE** Anschlussfähig EASY MANIFOLD, geliefert ohne Druck + Verbindungsdichtung
- FR** Connectable EASY MANIFOLD, fourni sans pression + joint de connexion
- ES** Connectable EASY MANIFOLD, suministrado sin presión + junta de conexión
- PT** Acompláveis EASY MANIFOLD, fornecidos sem pressão + vedantes de conexão



OSAS + OSM = OVER STROKE ACTIVE SAFETY + OVER STROKE MARKER

ACTIVE SAFETY

easyl MANIFOLD p. 211



OSAS

* F_{1i} = Isothermal end force at 100% Cu p. 16

** F_{1p} = Polytropic end force at 100% Cu



USAS

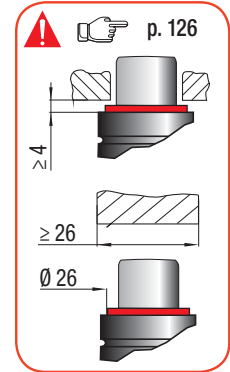
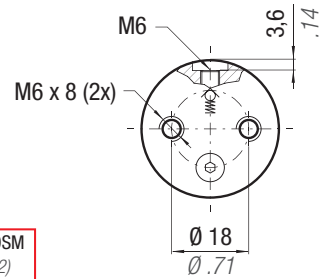
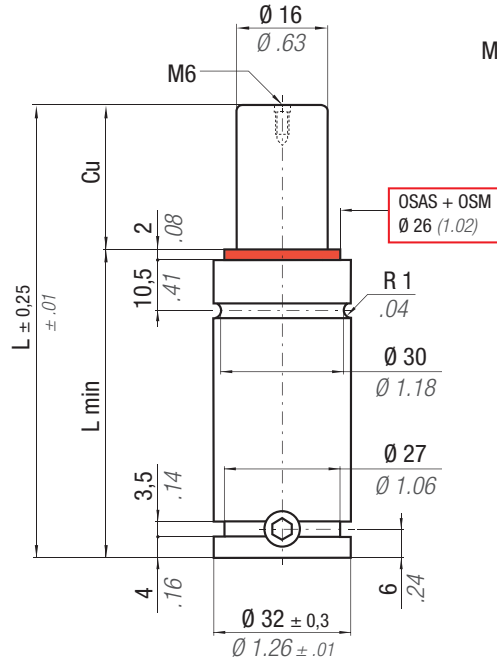

CODE	N ₂	°F 32 - 176	°C 0 - 80	ΔP ± 0,33 %/°C	P max 150 bar 2175 psi	P min 20 bar 290 psi	S 2,01 cm ² 0,312 in ²	SPM ~ 30 ÷ 100 (at 20°C)	Max Speed 1,8 m/s	Maintenance kit 39BMRV00350C	Vo		PED		
											cm ³	in ³	~Kg	~lb	2014/68/EU
H 300 - 010 - C											17,0	1,04	0,22	0,49	✓
H 300 - 013 - C											19,0	1,16	0,23	0,51	✓
H 300 - 016 - C											21,0	1,28	0,24	0,53	✓
H 300 - 025 - C											26,0	1,59	0,26	0,57	✓
H 300 - 038 - C											34,0	2,07	0,31	0,68	✓
H 300 - 050 - C											41,0	2,50	0,35	0,77	✓
H 300 - 063 - C											49,0	2,99	0,39	0,86	✓
H 300 - 080 - C											59,0	3,60	0,44	0,97	✓
H 300 - 100 - C											71,0	4,33	0,51	1,12	✓
H 300 - 125 - C											86,0	5,25	0,59	1,30	✓

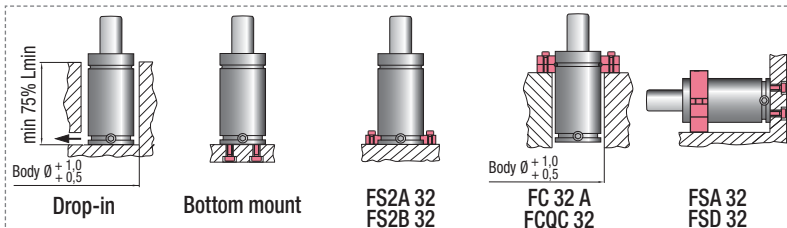

HOW TO ORDER
(10 pcs) H 300-050-C
(10 pcs) H 300-050-C-N

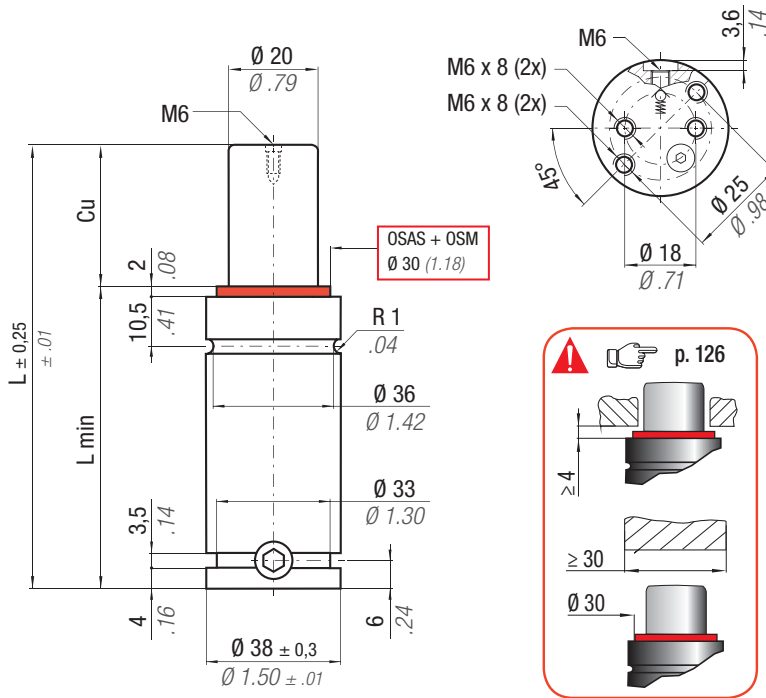

OSAS + OSM = OVER STROKE ACTIVE SAFETY + OVER STROKE MARKER



easu MANIFOLD p. 211

ACTIVE SAFETY

* F_{1i} =

Isothermal end force at 100% Cu p. 16

** F_{1p} =

Polytropic end force at 100% Cu



OSAS



USAS



OPAS

	$^{\circ}\text{F}$ 32 - 176	$^{\circ}\text{C}$ 0 - 80	ΔP $\pm 0,33\% / ^{\circ}\text{C}$	P max 150 bar 2175 psi	P min 20 bar 290 psi	S 3,14 cm ² 0.487 in ²	SPM ~ 30 - 100 (at 20°C)	Max Speed 1,8 m/s	Maintenance kit 39BMRV00500C
--	--------------------------------------	------------------------------------	---	-------------------------------------	-----------------------------------	---	---------------------------------------	-----------------------------	--

CODE	Cu		L		L min		F ₀		F _{1i} *		F _{1p} **		V ₀		PED		
	mm	inch	mm	inch	mm	inch	daN	lb	daN	lb	daN	lb	cm ³	in ³	~Kg	~lb	2014/68/EU
H 500 - 010 - C	10	0.39	70	2.76	60	2.36	470 1057 ± 5% 150 bar 2175 psi + 20 °C +68 °F		559	1257	619	1391	24,0	1.46	0,32	0.71	✓
H 500 - 013 - C	13	0.51	75,7	2.98	62,7	2.47			578	1300	647	1455	26,0	1.59	0,33	0.73	✓
H 500 - 016 - C	16	0.63	82	3.23	66	2.60			593	1333	669	1504	29,0	1.77	0,34	0.75	✓
H 500 - 019 - C	19	0.75	88	3.46	69	2.72			606	1363	690	1550	31,0	1.89	0,36	0.79	✓
H 500 - 025 - C	25	0.98	100	3.94	75	2.95			629	1415	724	1628	36,0	2.20	0,39	0.86	✓
H 500 - 038 - C	38	1.50	126	4.96	88	3.46			664	1494	778	1750	48,0	2.93	0,45	0.99	✓
H 500 - 050 - C	50	1.97	150	5.91	100	3.94			687	1544	813	1828	58,0	3.54	0,50	1.10	✓
H 500 - 063 - C	63	2.48	176,5	6.95	113,5	4.47			702	1579	838	1883	70,0	4.27	0,57	1.26	✓
H 500 - 080 - C	80	3.15	210	8.27	130	5.12			721	1620	867	1948	84,0	5.12	0,64	1.41	✓
H 500 - 100 - C	100	3.94	250	9.84	150	5.91			734	1651	889	1998	101,0	6.16	0,74	1.63	✓
H 500 - 125 - C	125	4.92	300	11.81	175	6.89			746	1678	908	2042	123,0	7.50	0,86	1.90	✓

H
HF

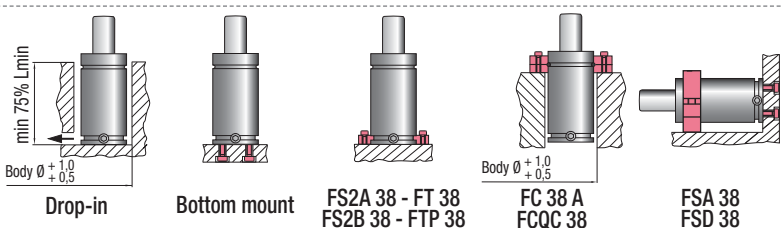

HOW TO ORDER

(10 pcs) H 500-050-C
(10 pcs) H 500-050-C-N



OSAS + OSM = OVER STROKE ACTIVE SAFETY + OVER STROKE MARKER

ACTIVE SAFETY



OSAS



USAS



OPAS

Il nuovo codice sarà fornito solo ad esaurimento del vecchio

The new code will be supplied only when the old will be out of stock

Der neue Kode wird geliefert nur wenn der alte nicht mehr im Lager ist

Le nouveau code sera fourni uniquement lorsque le vieux stock sera écoulé

El nuevo código será suministrado sólo cuando el viejo está fuera de stock

O novo código irá ser fornecido apenas quando o antigo esgotar stock

* $F_{1i} =$

Isothermal end force at 100% Cu p. 16

** $F_{1p} =$

Polytropic end force at 100% Cu

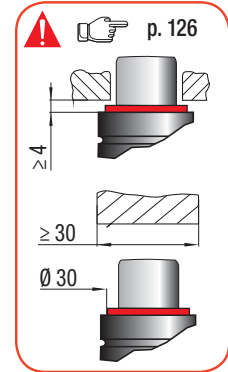
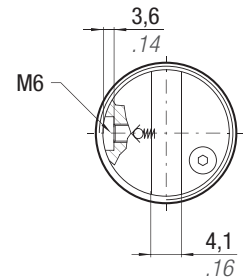
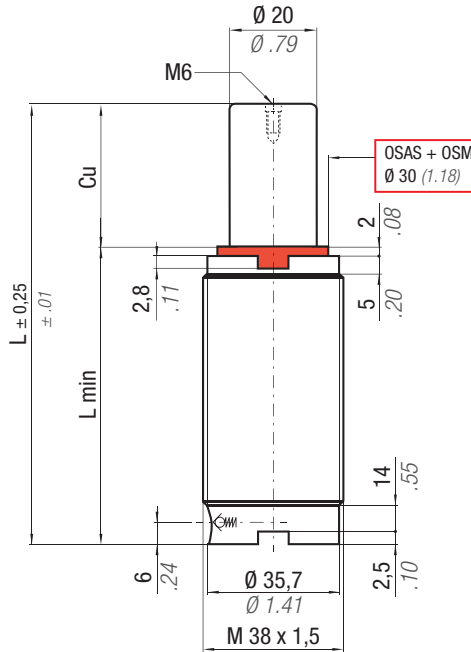

		°F 32 - 176	°C 0 - 80	ΔP ± 0,33 %/°C	P max 150 bar 2175 psi	P min 20 bar 290 psi	S 3,14 cm ² 0,487 in ²	SPM ~ 30 ÷ 100 (at 20°C)	Max Speed 1,8 m/s	Maintenance kit 39BMRV00500C								
CODE	NEW	Cu		L		L min		F ₀		F _{1i} *		F _{1p} **		V ₀				
PHASING OUT from 09/2009		mm	inch	mm	inch	mm	inch	daN	lb	daN	lb	daN	lb	cm ³	in ³		~Kg	~lb
HF 500 - 010 - A	HF 500 - 010 - C	10	0.39	70	2.76	60	2.36	470 ± 5% 1057 150 bar 2175 psi + 20 °C +68 °F		559	1257	619	1391	24,0	1.46	0,31	0,68	✓
HF 500 - 013 - A	HF 500 - 013 - C	13	0.51	75,7	2.98	62,7	2.47			578	1300	647	1455	26,0	1.59	0,32	0,71	✓
HF 500 - 016 - A	HF 500 - 016 - C	16	0.63	82	3.23	66	2.60			593	1333	669	1504	29,0	1.77	0,34	0,75	✓
-	HF 500 - 019 - C	19	0.75	88	3.46	69	2.72			606	1363	690	1550	31,0	1.89	0,35	0,77	✓
HF 500 - 025 - A	HF 500 - 025 - C	25	0.98	100	3.94	75	2.95			629	1415	724	1628	36,0	2.20	0,38	0,84	✓
HF 500 - 038 - A	HF 500 - 038 - C	38	1.50	126	4.96	88	3.46			664	1494	778	1750	48,0	2.93	0,44	0,97	✓
HF 500 - 050 - A	HF 500 - 050 - C	50	1.97	150	5.91	100	3.94			687	1544	813	1828	58,0	3.54	0,50	1.10	✓
HF 500 - 063 - A	HF 500 - 063 - C	63	2.48	176,5	6.95	113,5	4.47			702	1579	838	1883	70,0	4.27	0,56	1.23	✓
HF 500 - 080 - A	HF 500 - 080 - C	80	3.15	210	8.27	130	5.12			721	1620	867	1948	84,0	5.12	0,64	1.41	✓
HF 500 - 100 - A	HF 500 - 100 - C	100	3.94	250	9.84	150	5.91			734	1651	889	1998	101,0	6.16	0,73	1.61	✓
HF 500 - 125 - A	HF 500 - 125 - C	125	4.92	300	11.81	175	6.89			746	1678	908	2042	123,0	7.50	0,85	1.87	✓

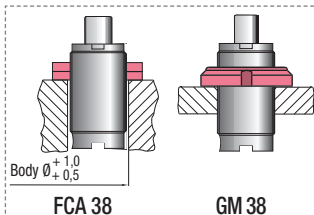

HOW TO ORDER

(10 pcs) HF 500-050-C
(10 pcs) HF 500-050-C-N

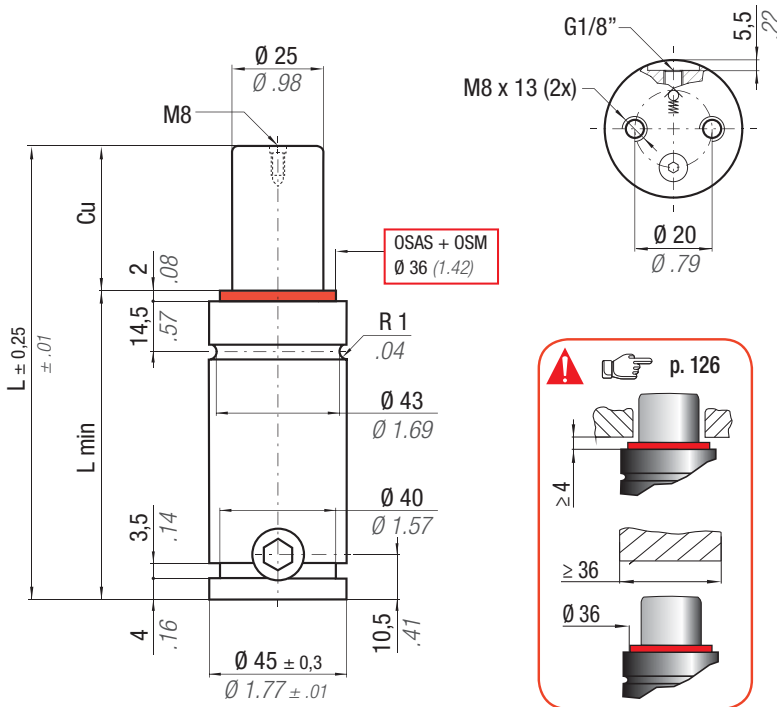

OSAS + OSM = OVER STROKE ACTIVE SAFETY + OVER STROKE MARKER



ACTIVE SAFETY



OSAS



USAS



OPAS

Il nuovo codice sarà fornito solo ad esaurimento del vecchio

The new code will be supplied only when the old will be out of stock

Der neue Kode wird geliefert nur wenn der alte nicht mehr im Lager ist

Le nouveau code sera fourni uniquement lorsque le vieux stock sera écoulé

El nuevo código será suministrado sólo cuando el viejo está fuera de stock

O novo código irá ser fornecido apenas quando o antigo esgotar stock

easu MANIFOLD p. 211

* $F_{1i} =$

Isothermal end force at 100% Cu p. 16

** $F_{1p} =$

Polytrophic end force at 100% Cu

	$^{\circ}\text{F}$ 32 - 176	$^{\circ}\text{C}$ 0 - 80	ΔP $\pm 0,33\% / ^{\circ}\text{C}$	P max 150 bar 2175 psi	P min 20 bar 290 psi	S 4,91 cm ² 0.761 in ²	SPM ~ 20 ÷ 100 (at 20°C)	Max Speed 1,8 m/s	Maintenance kit See Tab below
--	--------------------------------------	------------------------------------	---	-------------------------------------	-----------------------------------	---	---------------------------------------	-----------------------------	---

CODE PHASING OUT from 01/2018	NEW	Cu		L		L min		F0 Initial force		F _{1i} *		F _{1p} **		V0		PED 2014/68/EU		
		mm	inch	mm	inch	mm	inch	daN	lb	daN	lb	daN	lb	cm ³	in ³	~Kg	~lb	✓
H 700 - 010 - C	H 700 - 010 - D	10	0.39	105	4.13	95	3.74	740 1664 ± 5%	150 bar 2175 psi	811	1823	876	1969	63,0	3.84	0,90	1.98	✓
H 700 - 013 - C	H 700 - 013 - D	13	0.50	110,7	4.35	97,7	3.85			830	1866	904	2032	67,0	4.09	0,91	2.01	✓
H 700 - 025 - C	H 700 - 025 - D	25	0.98	135	5.31	110	4.33			893	2008	995	2237	82,0	5.00	1,00	2.20	✓
H 700 - 038 - C	H 700 - 038 - D	38	1.50	161	6.34	123	4.84			945	2124	1073	2412	99,0	6.04	1,09	2.40	✓
H 700 - 050 - C	H 700 - 050 - D	50	1.97	185	7.28	135	5.31			983	2210	1131	2543	114,0	6.95	1,17	2.58	✓
H 700 - 063 - C	H 700 - 063 - D	63	2.48	211,5	8.33	148,5	5.85			1014	2280	1179	2650	131,0	7.99	1,26	2.78	✓
H 700 - 080 - C	H 700 - 080 - D	80	3.15	245	9.65	165	6.50			1050	2360	1235	2776	152,0	9.27	1,37	3.02	✓
H 700 - 100 - C	H 700 - 100 - D	100	3.94	285	11.22	185	7.28			1228	2761	1520	3418	140,0	8.54	1,51	3.33	✓
H 700 - 125 - C	H 700 - 125 - D	125	4.92	335	13.19	210	8.27			1244	2796	1546	3475	172,0	10.49	1,67	3.68	✓
H 700 - 160 - C	H 700 - 160 - D	160	6.30	405	15.94	245	9.65			1258	2827	1569	3527	217,0	13.24	1,91	4.21	✓

Model (Cu)	Rev.	Maintenance kit
H 700 (010 ÷ 080)	C	39BMRV00750B
H 700 (100 ÷ 160)	C	39BMH00700C
H 700 (010 ÷ 160)	D	39BMH00700D

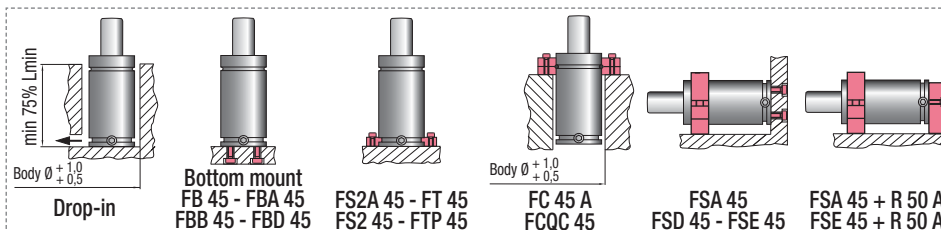

HOW TO ORDER

(10 pcs) H 700-050-C
(10 pcs) H 700-050-C-N



OSAS + OSM = OVER STROKE ACTIVE SAFETY + OVER STROKE MARKER

ACTIVE SAFETY



OSAS



USAS



OPAS

Il nuovo codice sarà fornito solo ad esaurimento del vecchio
The new code will be supplied only when the old will be out of stock
Der neue Kode wird geliefert nur wenn der alte nicht mehr im Lager ist
Le nouveau code sera fourni uniquement lorsque le vieux stock sera écoulé
El nuevo código será suministrado sólo cuando el viejo está fuera de stock
O novo código irá ser fornecido apenas quando o antigo esgotar stock

easu MANIFOLD p. 211

* F_{1i} = Isothermal end force at 100% Cu p. 16
** F_{1p} = Polyphropic end force at 100% Cu

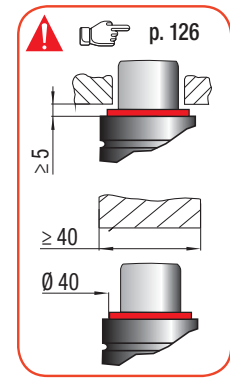
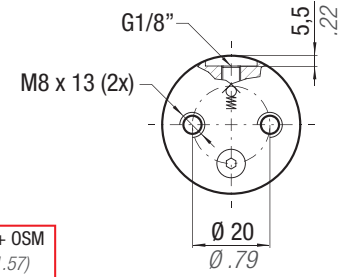
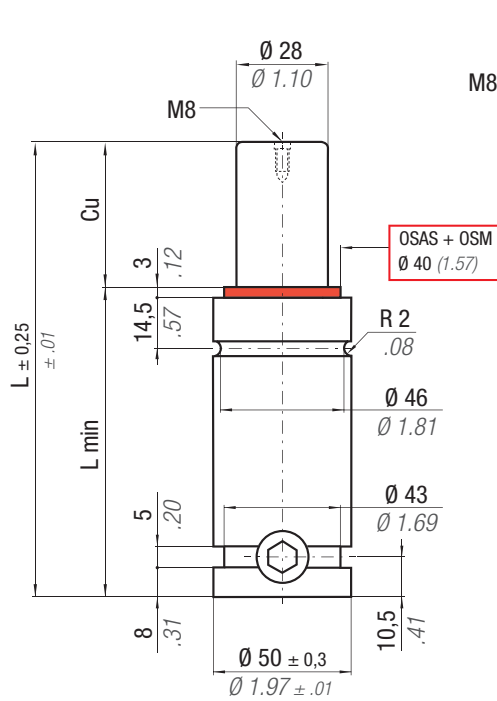

N ₂	°F 32 - 176	°C 0 - 80	ΔP ± 0,33 %/°C	P max 150 bar 2175 psi	P min 20 bar 290 psi	S 6,15 cm ² 0,953 in ²	SPM ~ 15 ÷ 100 (at 20°C)	Max Speed 1,8 m/s	Maintenance kit See Tab below
----------------	----------------------	--------------------	---------------------------	------------------------------	----------------------------	--	--------------------------------	----------------------	----------------------------------

CODE PHASING OUT from 01/2018	NEW	Cu		L		L min		F ₀ Initial force		F _{1i} * End force *		F _{1p} ** End force **		V ₀		PED 2014/68/EU		
		mm	inch	mm	inch	mm	inch	daN	lb	daN	lb	daN	lb	cm ³	in ³	~Kg	~lb	
H 1000 - 013 - C	H 1000 - 013 - D	13	0.50	120,7	4.74	107,7	4.24	920 ± 5% 150 bar 2175 psi + 20 °C +68 °F		1181	2655	1340	3012	43,0	2.62	1,21	2,67	✓
H 1000 - 025 - C	H 1000 - 025 - D	25	0.98	145	5.71	120	4.72			1297	2916	1517	3410	62,0	3.78	1,32	2,91	✓
H 1000 - 038 - C	H 1000 - 038 - D	38	1.50	171	6.73	133	5.24			1374	3089	1638	3682	83,0	5.06	1,43	3,15	✓
H 1000 - 050 - C	H 1000 - 050 - D	50	1.97	195	7.68	145	5.71			1421	3195	1713	3851	101,0	6.16	1,53	3,37	✓
H 1000 - 063 - C	H 1000 - 063 - D	63	2.48	221	8.74	158	6.22			1458	3278	1772	3984	122,0	7.44	1,64	3,62	✓
H 1000 - 075 - C	H 1000 - 075 - D	75	2.95	245	9.65	170	6.69			1483	3334	1814	4078	141,0	8.60	1,74	3,84	✓
H 1000 - 080 - C	H 1000 - 080 - D	80	3.15	255	10.04	175	6.89			1492	3354	1828	4110	149,0	9.09	1,78	3,92	✓
H 1000 - 100 - C	H 1000 - 100 - D	100	3.94	295	11.61	195	7.68			1521	3419	1874	4214	180,0	10.98	1,96	4.32	✓
H 1000 - 125 - C	H 1000 - 125 - D	125	4.92	345	13.58	220	8.66			1546	3475	1915	4305	219,0	13.36	2,17	4.78	✓
H 1000 - 150 - C	H 1000 - 150 - D	150	5.91	395	15.55	245	9.65			1563	3515	1944	4371	258,0	15.74	2,38	5.25	✓
H 1000 - 160 - C	H 1000 - 160 - D	160	6.30	415	16.34	255	10.04			1569	3528	1954	4393	274,0	16.71	2,46	5.42	✓
H 1000 - 175 - C	H 1000 - 175 - D	175	6.89	445	17.52	270	10.63			1577	3545	1966	4421	298,0	18.18	2,59	5.71	✓
H 1000 - 200 - C	H 1000 - 200 - D	200	7.87	495	19.49	295	11.61			1587	3568	1984	4459	337,0	20.56	2,79	6.15	✓
H 1000 - 250 - C	H 1000 - 250 - D	250	9.84	595	23.43	345	13.58			1602	3602	2009	4515	416,0	25.38	3,21	7.08	✓
H 1000 - 300 - C	H 1000 - 300 - D	300	11.81	695	27.36	395	15.55			1613	3625	2026	4554	494,0	30.13	3,63	8.00	✓

Model (Cu)	Rev.	Maintenance kit
H 1000 (013 ÷ 080)	C	39BMRV01000B
H 1000 (100 ÷ 300)	C	39BMH01000D
H 1000 (013 ÷ 300)	D	39BMH01000D

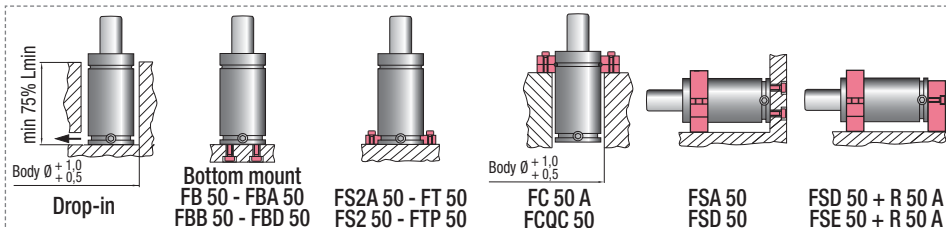

HOW TO ORDER

(10 pcs) H 1000-050-C
(10 pcs) H 1000-050-C-N

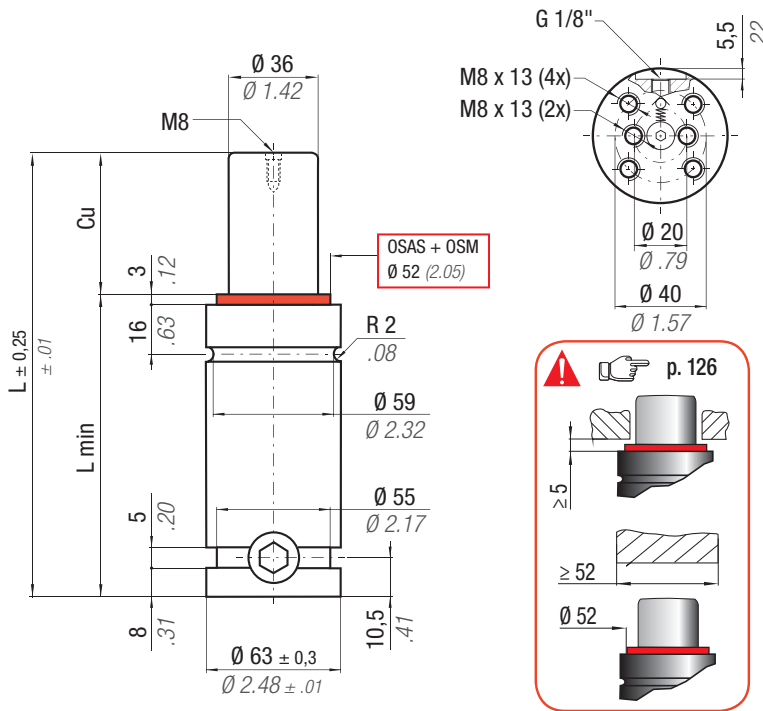

OSAS + OSM = OVER STROKE ACTIVE SAFETY + OVER STROKE MARKER



easu MANIFOLD p. 211

* F_{1i} = Isothermal end force at 100% Cu
 ** F_{1p} = Polytrophic end force at 100% Cu

ACTIVE SAFETY



OSAS



USAS



OPAS

	$^{\circ}\text{F}$ 32 - 176	$^{\circ}\text{C}$ 0 - 80	ΔP $\pm 0,33\% / ^{\circ}\text{C}$	P max 150 bar 2175 psi	P min 20 bar 290 psi	S 10,17 cm ² 1.576 in ²	SPM ~ 15 ÷ 100 (at 20°C)	Max Speed 1,8 m/s	Maintenance kit 39BMH01500C Cu 13 ÷ 80 39BMH01500CH Cu 100 ÷ 300
--	--------------------------------	------------------------------	---	-------------------------------------	-----------------------------------	--	---------------------------------------	-----------------------------	---

CODE	Cu		L		L min		F ₀ Initial force		F _{1i} * End force		F _{1p} ** End force		V ₀		PED 2014/68/EU		
	mm	inch	mm	inch	mm	inch	daN	lb	daN	lb	daN	lb	cm ³	in ³	~Kg	~lb	
H 1500 - 013 - C	13	0,51	120,7	4.75	107,7	4.24			1954	4393	2217	4984	71,0	4.33	1,98	4.37	✓
H 1500 - 025 - C	25	0,98	145	5.71	120	4.72			2139	4809	2500	5620	103,0	6.28	2,13	4.70	✓
H 1500 - 038 - C	38	1,50	171	6.73	133	5.24			2261	5083	2691	6050	138,0	8.42	2,29	5.05	✓
H 1500 - 050 - C	50	1,97	195	7.68	145	5.71			2335	5249	2809	6315	170,0	10.37	2,44	5.38	✓
H 1500 - 063 - C	63	2,48	221	8.70	158	6.22			2392	5377	2900	6519	204,0	12.44	2,60	5.73	✓
H 1500 - 075 - C	75	2,95	245	9.65	170	6.69	1530	3440	2431	5465	2964	6663	236,0	14.40	2,75	6.06	✓
H 1500 - 080 - C	80	3,15	255	10.04	175	6.89	$\pm 5\%$		2445	5497	2986	6713	249,0	15.19	2,81	6.19	✓
H 1500 - 100 - C	100	3,94	295	11.61	195	7.68	150 bar		2489	5595	3057	6872	302,0	18.42	3,03	6.68	✓
H 1500 - 125 - C	125	4,92	345	13.58	220	8.66	2175 psi		2527	5681	3119	7012	369,0	22.51	3,34	7.36	✓
H 1500 - 150 - C	150	5,91	395	15.55	245	9.65	$+ 20\text{ }^{\circ}\text{C} + 68\text{ }^{\circ}\text{F}$		2554	5742	3164	7113	435,0	26.54	3,64	8.02	✓
H 1500 - 160 - C	160	6,30	415	16.34	255	10.04			2563	5762	3178	7144	462,0	28.18	3,77	8.31	✓
H 1500 - 175 - C	175	6,89	445	17.52	270	10.63			2574	5787	3197	7187	501,0	30.56	3,95	8.71	✓
H 1500 - 200 - C	200	7,87	495	19.49	295	11.61			2590	5823	3223	7246	568,0	34.65	4,26	9.39	✓
H 1500 - 250 - C	250	9,84	595	23.43	345	13.58			2613	5874	3261	7331	701,0	42.76	4,87	10.74	✓
H 1500 - 300 - C	300	11,81	695	27.36	395	15.55			2628	5908	3287	7389	833,0	50.81	5,48	12.08	✓

H HF

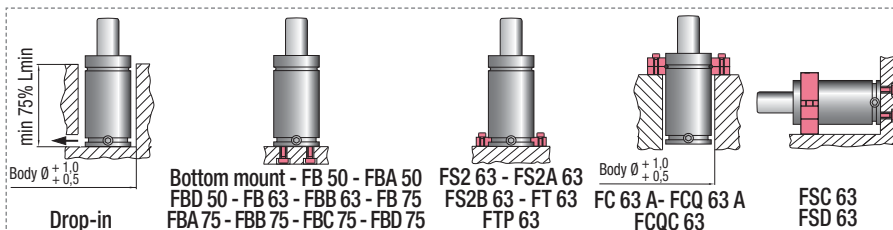

HOW TO ORDER

(10 pcs) H 1500-050-C
 (10 pcs) H 1500-050-C-N



OSAS + OSM = **OVER STROKE ACTIVE SAFETY** + **OVER STROKE MARKER**

ACTIVE SAFETY



OSAS



USAS



OPAS

Il nuovo codice sarà fornito solo ad esaurimento del vecchio
The new code will be supplied only when the old will be out of stock
Der neue Kode wird geliefert nur wenn der alte nicht mehr im Lager ist
Le nouveau code sera fourni uniquement lorsque le vieux stock sera écoulé
El nuevo código será suministrado sólo cuando el viejo está fuera de stock
O novo código irá ser fornecido apenas quando o antigo esgotar stock

easu MANIFOLD p. 211

* F_{1i} = Isothermal end force at 100% Cu p. 16
** F_{1p} = Polytrophic end force at 100% Cu

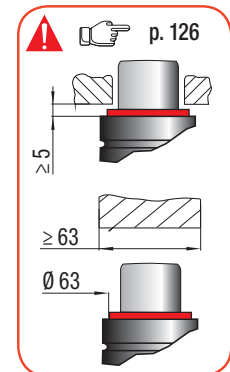
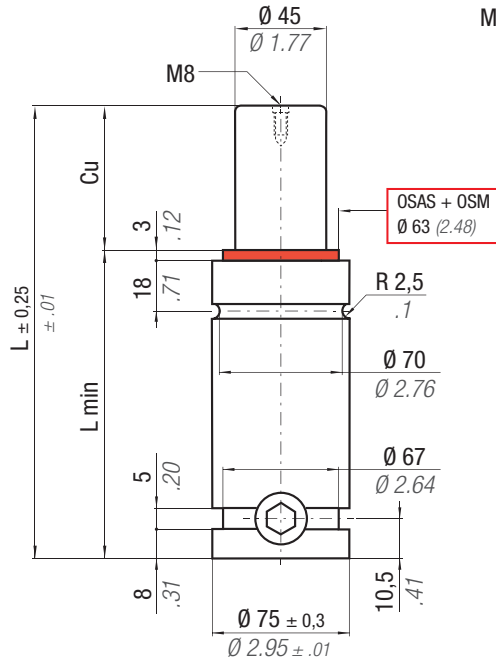

	$^{\circ}\text{F}$ 32 -176	$^{\circ}\text{C}$ 0 -80	ΔP $\pm 0,33\% / ^{\circ}\text{C}$	P max 150 bar 2175 psi	P min 20 bar 290 psi	S 15,9 cm ² 2.465 in ²	SPM ~ 15 ÷ 100 (at 20°C)	Max Speed 1,8 m/s	Maintenance kit See Tab below
--	----------------------------------	--------------------------------	---	-------------------------------------	-----------------------------------	---	---------------------------------------	-----------------------------	---

CODE PHASING OUT from 01/2018	NEW	Cu		L		L min		F ₀ Initial force		F _{1i} * End force *		F _{1p} ** End force **		V ₀		~Kg	~lb	 2014/68/EU
		mm	inch	mm	inch	mm	inch	daN	lb	daN	lb	daN	lb	cm ³	in ³			
H 2400 - 025 - C	H 2400 - 025 - D	25	0.98	160	6.30	135	5.31	2385 5362 ± 5%	150 bar 2175 psi	3238	7279	3745	8419	176,0	10.74	3,34	7.36	✓
H 2400 - 038 - C	H 2400 - 038 - D	38	1.50	186	7.32	148	5.83			3442	7738	4062	9132	228,0	13.91	3,55	7.83	✓
H 2400 - 050 - C	H 2400 - 050 - D	50	1.97	210	8.27	160	6.30			3573	8032	4269	9597	276,0	16.84	3,75	8.27	✓
H 2400 - 063 - C	H 2400 - 063 - D	63	2.48	236	9.31	173	6.81			3678	8268	4436	9973	329,0	20.07	3,96	8.73	✓
H 2400 - 075 - C	H 2400 - 075 - D	75	2.95	260	10.24	185	7.28			3752	8435	4555	10240	377,0	23.00	4,15	9.15	✓
H 2400 - 080 - C	H 2400 - 080 - D	80	3.15	270	10.63	190	7.48			3778	8493	4597	10334	397,0	24.22	4,23	9.33	✓
H 2400 - 100 - C	H 2400 - 100 - D	100	3.94	310	12.20	210	8.27			3863	8684	4735	10645	478,0	29.16	4,51	9.94	✓
H 2400 - 125 - C	H 2400 - 125 - D	125	4.92	360	14.17	235	9.25			3939	8855	4859	10923	578,0	35.26	4,91	10.82	✓
H 2400 - 150 - C	H 2400 - 150 - D	150	5.91	410	16.14	260	10.24			3994	8979	4949	11126	679,0	41.42	5,32	11.73	✓
H 2400 - 160 - C	H 2400 - 160 - D	160	6.30	430	16.93	270	10.63			4012	9019	4979	11193	719,0	43.86	5,49	12.10	✓
H 2400 - 175 - C	H 2400 - 175 - D	175	6.89	460	18.11	285	11.22	4036	9073	5018	11281	779,0	47.52	5,73	12.63	✓		
H 2400 - 200 - C	H 2400 - 200 - D	200	7.87	510	20.08	310	12.20	4068	9145	5072	11403	880,0	53.68	6,14	13.54	✓		
H 2400 - 250 - C	H 2400 - 250 - D	250	9.84	610	24.02	360	14.17	4116	9253	5152	11582	1081,0	65.94	6,95	15.32	✓		
H 2400 - 275 - C	H 2400 - 275 - D	275	10.83	660	25.98	385	15.16	4135	9296	5182	11650	1182,0	72.10	7,36	16.23	✓		
H 2400 - 300 - C	H 2400 - 300 - D	300	11.81	710	27.95	410	16.14	4150	9330	5208	11707	1283,0	78.26	7,77	17.13	✓		

Model (Cu)	Rev.	Maintenance kit
H 2400 (025 ÷ 080)	C	39BMRV02400B
H 2400 (025 ÷ 080)	D	39BMH02400D
H 2400 (100 ÷ 300)	C - D	39BMH02400DH

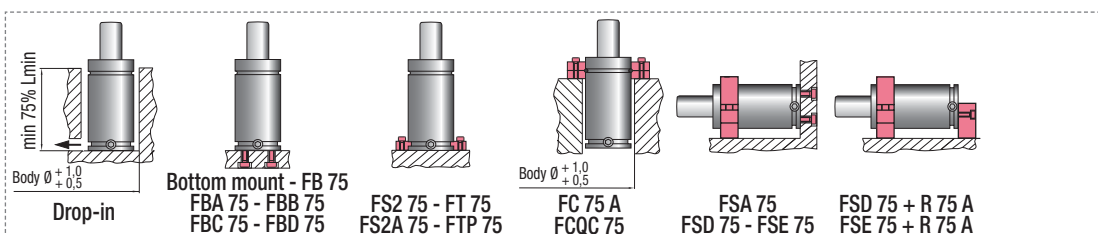

HOW TO ORDER
(10 pcs) H 2400-050-C
(10 pcs) H 2400-050-C-N

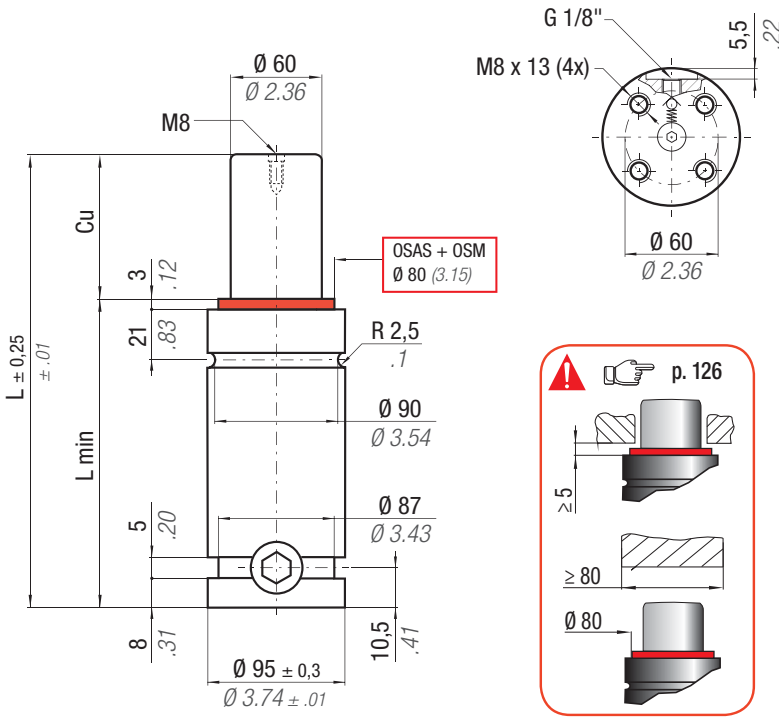

OSAS + OSM = OVER STROKE ACTIVE SAFETY + OVER STROKE SAFETY MARKER

Il nuovo codice sarà fornito solo ad esaurimento del vecchio
 The new code will be supplied only when the old will be out of stock
 Der neue Kode wird geliefert nur wenn der alte nicht mehr im Lager ist
 Le nouveau code sera fourni uniquement lorsque le vieux stock sera écoulé
 El nuevo código será suministrado sólo cuando el viejo está fuera de stock
 O novo código irá ser fornecido apenas quando o antigo esgotar stock

easu MANIFOLD p. 211

* F_{1i} = Isothermal end force at 100% Cu p. 16
 ** F_{1p} = Polytrophic end force at 100% Cu



ACTIVE SAFETY



OSAS



USAS



OPAS

	$^{\circ}\text{F}$ 32 - 176	$^{\circ}\text{C}$ 0 - 80	ΔP ± 0,33 %/°C	P max 150 bar 2175 psi	P min 20 bar 290 psi	S 28,27 cm ² 4.382 in ²	SPM ~ 15 ÷ 100 (at 20°C)	Max Speed 1,8 m/s	Maintenance kit See Tab below
--	--------------------------------------	------------------------------------	---------------------------------	-------------------------------------	-----------------------------------	--	---------------------------------------	-----------------------------	---

CODE PHASING OUT from 01/2018	NEW	Cu		L		L min		F0 Initial force		F1i *		F1p **		V0		PED 2014/68/EU		
		mm	inch	mm	inch	mm	inch	daN	lb	daN	lb	daN	lb	cm ³	in ³	~Kg	~lb	✓
H 4200 - 025 - C	H 4200 - 025 - D	25	0.98	170	6.69	145	5.71	4240 9532 ± 5%	150 bar 2175 psi	5817	13077	6753	15181	303,0	18.48	5,76	12.70	✓
H 4200 - 038 - C	H 4200 - 038 - D	38	1.50	196	7.72	158	6.22			6236	14019	7407	16652	388,0	23.67	6,12	13.49	✓
H 4200 - 050 - C	H 4200 - 050 - D	50	1.97	220	8.66	170	6.69			6515	14646	7850	17648	467,0	28.49	6,45	14.22	✓
H 4200 - 063 - C	H 4200 - 063 - D	63	2.48	246	9.70	183	7.20			6744	15161	8217	18473	552,0	33.67	6,80	14.99	✓
H 4200 - 075 - C	H 4200 - 075 - D	75	2.95	270	10.63	195	7.68			6908	15530	8484	19073	631,0	38.49	7,13	15.72	✓
H 4200 - 080 - C	H 4200 - 080 - D	80	3.15	280	11.02	200	7.87			6967	15662	8581	19291	663,0	40.44	7,27	16.03	✓
H 4200 - 100 - C	H 4200 - 100 - D	100	3.94	320	12.60	220	8.66			7160	16097	8898	20003	794,0	48.43	7,76	17.11	✓
H 4200 - 125 - C	H 4200 - 125 - D	125	4.92	370	14.57	245	9.65			7336	16491	9188	20656	958,0	58.44	8,45	18.63	✓
H 4200 - 150 - C	H 4200 - 150 - D	150	5.91	420	16.54	270	10.63			7465	16781	9403	21140	1122,0	68.44	9,13	20.13	✓
H 4200 - 160 - C	H 4200 - 160 - D	160	6.30	440	17.32	280	11.02			7507	16877	9475	21300	1185,0	72.41	9,40	20.72	✓
H 4200 - 175 - C	H 4200 - 175 - D	175	6.89	470	18.50	295	11.61	7564	17004	9569	21512	1285,0	78.39	9,82	21.65	✓		
H 4200 - 200 - C	H 4200 - 200 - D	200	7.87	520	20.47	320	12.60	7642	17179	9701	21808	1449,0	88.39	10,50	23.15	✓		
H 4200 - 250 - C	H 4200 - 250 - D	250	9.84	620	24.41	370	14.57	7758	17440	9897	22248	1776,0	108.34	11,87	26.17	✓		
H 4200 - 300 - C	H 4200 - 300 - D	300	11.81	720	28.35	420	16.54	7839	17623	10035	22560	2104,0	128.34	13,24	29.19	✓		

Model (Cu)	Rev.	Maintenance kit
H 4200 (025 ÷ 080)	C	39BMRV04200B
H 4200 (025 ÷ 080)	D	39BMH04200D
H 4200 (100 ÷ 300)	C - D	39BMH04200DH

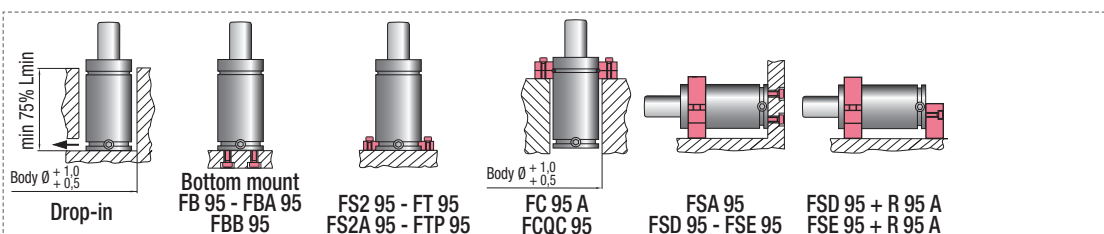

HOW TO ORDER

(10 pcs) H 4200-050-C
 (10 pcs) H 4200-050-C-N



OSAS + OSM = OVER STROKE ACTIVE SAFETY + OVER STROKE MARKER

ACTIVE SAFETY



OSAS



USAS



OPAS

Il nuovo codice sarà fornito solo ad esaurimento del vecchio
The new code will be supplied only when the old will be out of stock
Der neue Kode wird geliefert nur wenn der alte nicht mehr im Lager ist
Le nouveau code sera fourni uniquement lorsque le vieux stock sera écoulé
El nuevo código será suministrado sólo cuando el viejo está fuera de stock
O novo código irá ser fornecido apenas quando o antigo esgotar stock

easu MANIFOLD p. 211

* F_{1i} = Isothermal end force at 100% Cu p. 16
** F_{1p} = Polytrophic end force at 100% Cu

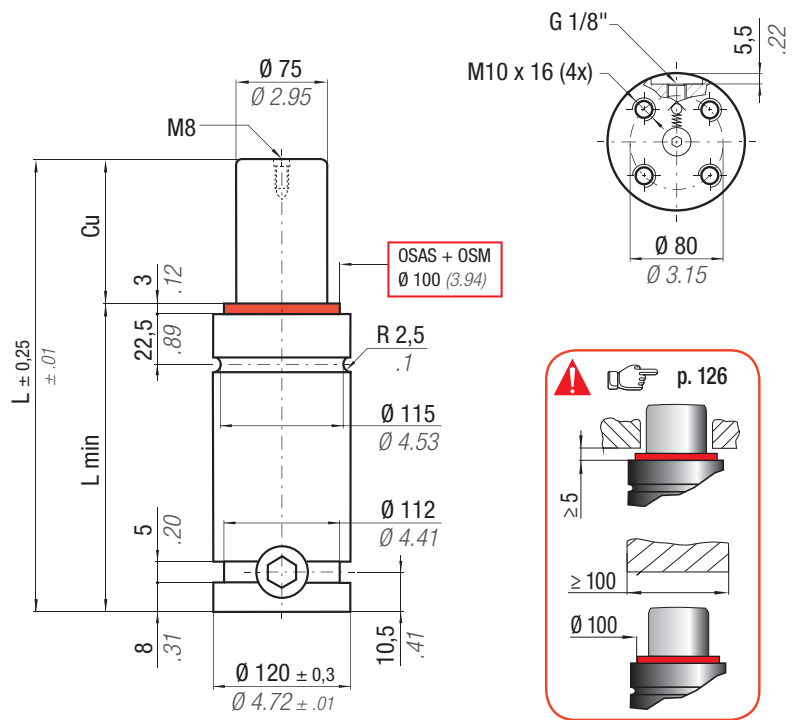

N₂	°F 32 -176	°C 0 -80	ΔP ± 0,33 %/°C	P max 150 bar 2175 psi	P min 20 bar 290 psi	S 44,18 cm ² 6.848 in ²	SPM ~ 15 ÷ 100 (at 20°C)	Max Speed 1,8 m/s	Maintenance kit See Tab below
----------------------	-------------------------	-----------------------	--------------------------	-------------------------------------	-----------------------------------	--	---------------------------------------	-----------------------------	---

CODE PHASING OUT from 01/2018	NEW	Cu		L		L min		F ₀ Initial force		F _{1i} * End force *		F _{1p} ** End force **		V ₀		~Kg ~lb	 2014/68/EU	
		mm	inch	mm	inch	mm	inch	daN	lb	daN	lb	daN	lb	cm ³	in ³			
H 6600 - 025 - C	H 6600 - 025 - D	25	0.98	190	7.48	165	6.50	6630 14904 ± 5%	150 bar 2175 psi	8601	19336	9806	22045	561,0	34.22	10,35	22.82	✓
H 6600 - 038 - C	H 6600 - 038 - D	38	1.50	216	8.50	178	7.01			9183	20644	10696	24046	700,0	42.70	10,89	24.01	✓
H 6600 - 050 - C	H 6600 - 050 - D	50	1.97	240	9.45	190	7.48			9585	21548	11323	25455	828,0	50.51	11,37	25.07	✓
H 6600 - 063 - C	H 6600 - 063 - D	63	2.48	266	10.47	203	7.99			9924	22310	11857	26656	967,0	58.99	11,93	26.30	✓
H 6600 - 075 - C	H 6600 - 075 - D	75	2.95	290	11.42	215	8.46			10174	22872	12255	27550	1095,0	66.80	12,39	27.32	✓
H 6600 - 080 - C	H 6600 - 080 - D	80	3.15	300	11.81	220	8.66			10264	23074	12400	27876	1149,0	70.09	12,60	27.78	✓
H 6600 - 100 - C	H 6600 - 100 - D	100	3.94	340	13.39	240	9.45			10565	23751	12885	28967	1362,0	83.08	13,30	29.32	✓
H 6600 - 125 - C	H 6600 - 125 - D	125	4.92	390	15.35	265	10.43			10844	24378	13339	29987	1629,0	99.37	14,33	31.59	✓
H 6600 - 150 - C	H 6600 - 150 - D	150	5.91	440	17.32	290	11.42			11053	24848	13681	30756	1864,0	113.70	15,35	33.84	✓
H 6600 - 160 - C	H 6600 - 160 - D	160	6.30	460	18.11	300	11.81			11123	25005	13975	31417	2003,0	122.18	15,75	34.72	✓
H 6600 - 175 - C	H 6600 - 175 - D	175	6.89	490	19.29	315	12.40			11215	25212	13948	31356	2164,0	132.00	16,36	36.07	✓
H 6600 - 200 - C	H 6600 - 200 - D	200	7.87	540	21.26	340	13.39			11345	25505	14163	31840	2431,0	148.29	17,38	38.32	✓
H 6600 - 250 - C	H 6600 - 250 - D	250	9.84	640	25.20	390	15.35			11540	25943	14486	32566	2965,0	180.87	19,42	42.81	✓
H 6600 - 300 - C	H 6600 - 300 - D	300	11.81	740	29.13	440	17.32			11713	26332	14775	33216	3485,0	212.59	21,57	47.55	✓

Model (Cu)	Rev.	Maintenance kit
H 6600 (025 ÷ 080)	C	39BMRV06600B
H 6600 (025 ÷ 080)	D	39BMH06600D
H 6600 (100 ÷ 300)	C - D	39BMH06600DH

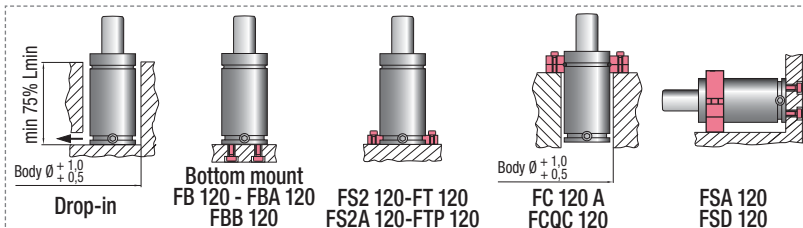

HOW TO ORDER

(10 pcs) H 6600-050-C
(10 pcs) H 6600-050-C-N

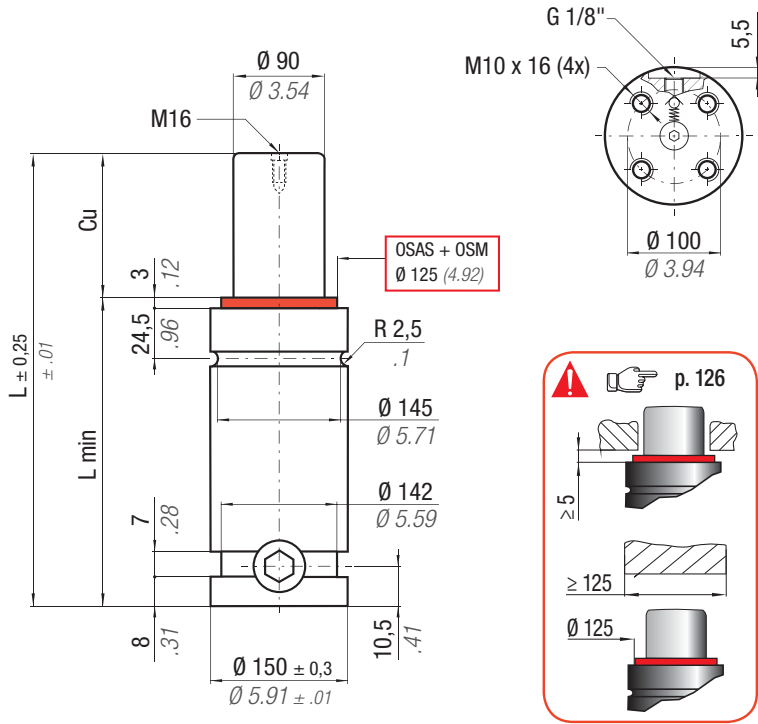

OSAS + OSM = OVER STROKE ACTIVE SAFETY + OVER STROKE MARKER

easyl MANIFOLD p. 211

* F_{1i} = Isothermal end force at 100% Cu p. 16
 ** F_{1p} = Polyphotic end force at 100% Cu

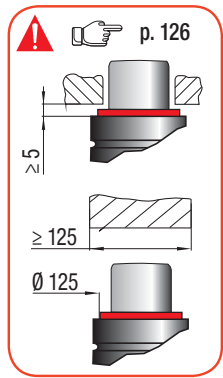

ACTIVE SAFETY



OSAS



USAS



OPAS

	°F 32 - 176	°C 0 - 80	ΔP ± 0,33 %/°C	P max 150 bar 2175 psi	P min 20 bar 290 psi	S 63,62 cm ² 9.861 in ²	SPM ~ 15 ÷ 80 (at 20°C)	Max Speed 1,8 m/s	Maintenance kit 39BMH09500C
--	----------------------	--------------------	---------------------------	-------------------------------------	-----------------------------------	--	--------------------------------------	-----------------------------	---------------------------------------

CODE	Cu		L		L min		F ₀		F _{1i} *		F _{1p} **		V ₀		PED				
	mm	inch	mm	inch	mm	inch	daN	lb	daN	lb	daN	lb	cm ³	in ³	~Kg	~lb	2014/68/EU		
H 9500 - 025 - C	25	0.98	205	8.07	180	7.09					12101	27204	13691	30779	879,0	53.62	18,00	39.68	✓
H 9500 - 038 - C	38	1.50	231	9.09	193	7.60					12866	28925	14853	33390	1089,0	66.43	18,82	41.49	✓
H 9500 - 050 - C	50	1.97	255	10.04	205	8.07					13398	30121	15673	35235	1282,0	78.20	19,58	43.17	✓
H 9500 - 063 - C	63	2.48	281	11.06	218	8.58					13848	31132	16376	36815	1492,0	91.01	20,41	45.00	✓
H 9500 - 075 - C	75	2.95	305	12.01	230	9.06					14181	31881	16901	37995	1685,0	102.79	21,17	46.67	✓
H 9500 - 080 - C	80	3.15	315	12.40	235	9.25					14302	32152	17092	38425	1766,0	107.73	21,49	47.38	✓
H 9500 - 100 - C	100	3.94	355	13.98	255	10.04					14705	33058	17735	39869	2088,0	127.37	22,76	50.18	✓
H 9500 - 125 - C	125	4.92	405	15.94	280	11.02					15080	33901	18337	41224	2491,0	151.95	24,35	53.68	✓
H 9500 - 150 - C	150	5.91	455	17.91	305	12.01					15361	34534	18793	42249	2894,0	176.53	25,94	57.19	✓
H 9500 - 160 - C	160	6.30	475	18.70	315	12.40					15455	34745	18946	42593	3055,0	186.36	26,58	58.60	✓
H 9500 - 175 - C	175	6.89	505	19.88	330	12.99					15581	35027	19150	43052	3297,0	201.12	27,53	60.69	✓
H 9500 - 200 - C	200	7.87	555	21.85	355	13.98					15756	35421	19437	43697	3700,0	225.70	29,12	64.20	✓
H 9500 - 250 - C	250	9.84	655	25.79	405	15.94					16020	36014	19870	44670	4506,0	274.87	32,30	71.21	✓
H 9500 - 300 - C	300	11.81	755	29.72	455	17.91					16208	36437	20181	45368	5312,0	324.03	35,47	78.20	✓

H
HF

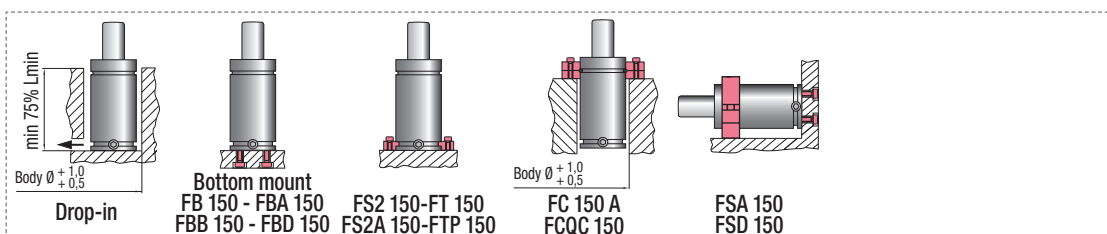

HOW TO ORDER

(10 pcs) H 9500-050-C
 (10 pcs) H 9500-050-C-N



ACTIVE SAFETY



OSAS



USAS



OPAS

OSAS + OSM = OVER STROKE ACTIVE SAFETY + OVER STROKE MARKER

Il nuovo codice sarà fornito solo ad esaurimento del vecchio

The new code will be supplied only when the old will be out of stock

Der neue Kode wird geliefert nur wenn der alte nicht mehr im Lager ist

Le nouveau code sera fourni uniquement lorsque le vieux stock sera écoulé

El nuevo código será suministrado sólo cuando el viejo está fuera de stock

O novo código irá ser fornecido apenas quando o antigo esgotar stock

easu MANIFOLD p. 211

* F_{1i} = Isothermal end force at 100% Cu p. 16
 ** F_{1p} = Polytrophic end force at 100% Cu

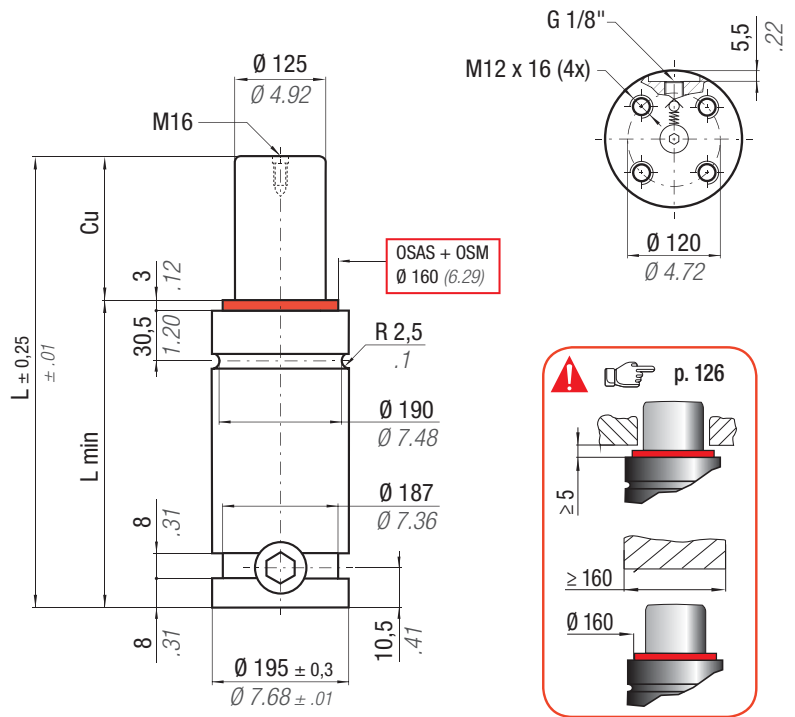

N₂	°F 32 - 176	°C 0 - 80	ΔP ± 0,33 %/°C	P max 150 bar 2175 psi	P min 20 bar 290 psi	S 122,7 cm ² 19.019 in ²	SPM ~ 10 ÷ 70 (at 20°C)	Max Speed 1,8 m/s	Maintenance kit 39BMH18500C
----------------------	-----------------------------	---------------------------	--------------------------	-------------------------------------	-----------------------------------	---	--------------------------------------	-----------------------------	---------------------------------------

CODE PHASING OUT from 01/2014	NEW	Cu		L		L min		F ₀		F _{1i} *		F _{1p} **		V ₀		~Kg	~lb	PED 2014/68/EU
		mm	inch	mm	inch	mm	inch	daN	lb	daN	lb	daN	lb	cm ³	in ³			
H 18500 - 025 - A	H 18500 - 025 - C	25	0.98	210	8.27	185	7.28	18400 ± 5%	41363	24062	54094	27495	61811	1522,0	92.84	31,06	68.48	✓
H 18500 - 038 - A	H 18500 - 038 - C	38	1.50	236	9.29	198	7.80			25812	58028	30182	67852	1886,0	115.05	32,53	71.72	✓
H 18500 - 050 - A	H 18500 - 050 - C	50	1.97	260	10.24	210	8.27			27045	60800	32111	72188	2221,0	135.48	33,89	74.71	✓
H 18500 - 063 - A	H 18500 - 063 - C	63	2.50	286	11.30	223	8.80			28022	62996	33660	75671	2599,0	158.54	35,36	77.96	✓
H 18500 - 080 - A	H 18500 - 080 - C	80	3.15	320	12.60	240	9.45			29171	65579	35505	79818	3060,0	186.66	37,28	82.19	✓
H 18500 - 100 - A	H 18500 - 100 - C	100	3.94	360	14.17	260	10.24			30132	67739	37066	83328	3619,0	220.76	39,54	87.17	✓
H 18500 - 125 - A	H 18500 - 125 - C	125	4.92	410	16.14	285	11.22			30132	67739	38544	86650	4318,0	263.40	42,37	93.41	✓
H 18500 - 160 - A	H 18500 - 160 - C	160	6.30	480	18.90	320	12.60			31942	71808	40050	90036	5297,0	323.12	46,33	102.14	✓
H 18500 - 200 - A	H 18500 - 200 - C	200	7.87	560	22.05	360	14.17			32675	73456	41276	92792	6415,0	391.32	50,85	112.11	✓
H 18500 - 250 - A	H 18500 - 250 - C	250	9.84	660	25.98	410	16.14			33321	74909	42363	95236	7813,0	476.59	56,51	124.58	✓
H 18500 - 300 - A	H 18500 - 300 - C	300	11.81	760	29.92	460	18.11	33582	75495	42805	96229	9282,0	566.20	62,16	137.04	✓		

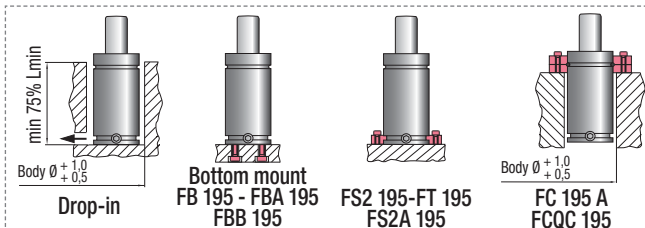

HOW TO ORDER

(10 pcs) H 18500-050-C
 (10 pcs) H 18500-050-C-N



THIS PAGE IS INTENTIONALLY LEFT BLANK

- **55 % noise**
- **50 % vibrations**

INITIAL IMPACT VIBRATIONS

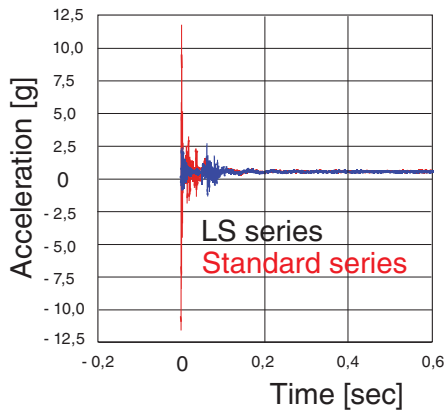

FORCE CURVE

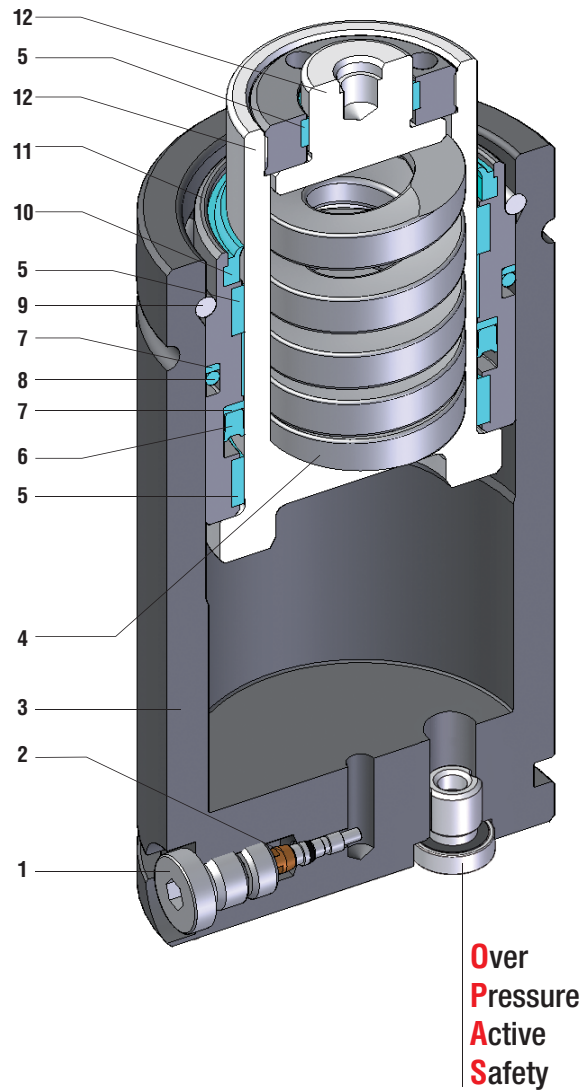
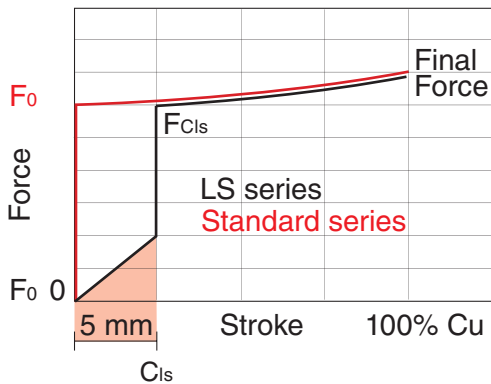

**Over
Pressure
Active
Safety**

Forza iniziale nulla - Zero force on contact - Ausgangsleistung null
 Force iniziale nulle - Fuerza inicial cero - Força inicial nula

SEALING	ROD SEAL
DESIGN	BUSH - BODY DESIGN

1	Plug	5	Guide ring	9	Retaining ring
2	Valve	6	Rod seal	10	Rod wiper
3	Body	7	Back-up ring	11	Bush
4	Spring	8	O-ring	12	Rod (nitrited superfinished)

RANGE CHART

Model	Body Ø		Stroke Cu		Initial force F0		OSAS	USAS	OPAS	SKUDO
	mm	inch	mm	inch	daN	lb				
LS 1500	75	2.95	25 - 300	0.98 - 11.81	1590	3574	-	-	✓	-
LS 2400	75	2.95	25 - 300	0.98 - 11.81	2385	5362	-	-	✓	-
LS 3000	95	3.74	25 - 300	0.98 - 11.81	2830	6362	-	-	✓	-
LS 4200	95	3.74	25 - 300	0.98 - 11.81	4240	9532	-	-	✓	-
LS 5000	120	4.72	25 - 300	0.98 - 11.81	4418	9932	-	-	✓	-
LS 6600	120	4.72	25 - 300	0.98 - 11.81	6630	14905	-	-	✓	-
LS 7500	150	5.91	25 - 300	0.98 - 11.81	7630	17152	✓	✓	✓	-
LS 9500	150	5.91	25 - 300	0.98 - 11.81	9540	21446	✓	✓	✓	-

HOW TO ORDER

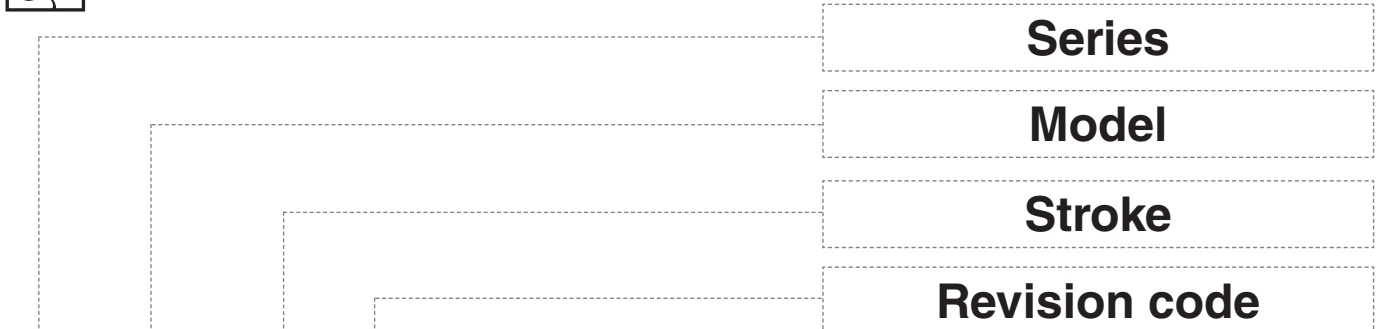

LS 2400-050-A - N

- IT** Codice cilindro autonomo
- EN** Self-contained cylinder code
- DE** Kode des eingeständigen Gdf.
- FR** Code du cylindre autonome
- ES** Codigo del cilindro autónomo
- PT** Codigo do cilindro autónomo

- IT** Collegabile con tubi, cilindro fornito scarico e senza valvola unidirezionale
- EN** Linkable with hoses, cylinder supplied without pressure and oneway valve
- DE** Anschlussfähig mit Leitungen, Gdf. geliefert ohne Druck und RückschlagVentil
- FR** Connectable avec tubes, ressort fourni sans pression ni valve unidirectionelle
- ES** Connectable con tubos, cilindro suministrado sin presión y sin válvula unidireccional
- PT** Acompláveis com tubos, cilindro fornecidos sem pressão e sem válvula unidireccional

ACTIVE SAFETY



* $F_{1i} =$ Isothermal end force at 100% Cu p. 16 **** $F_{1p} =$** Polytropic end force at 100% Cu

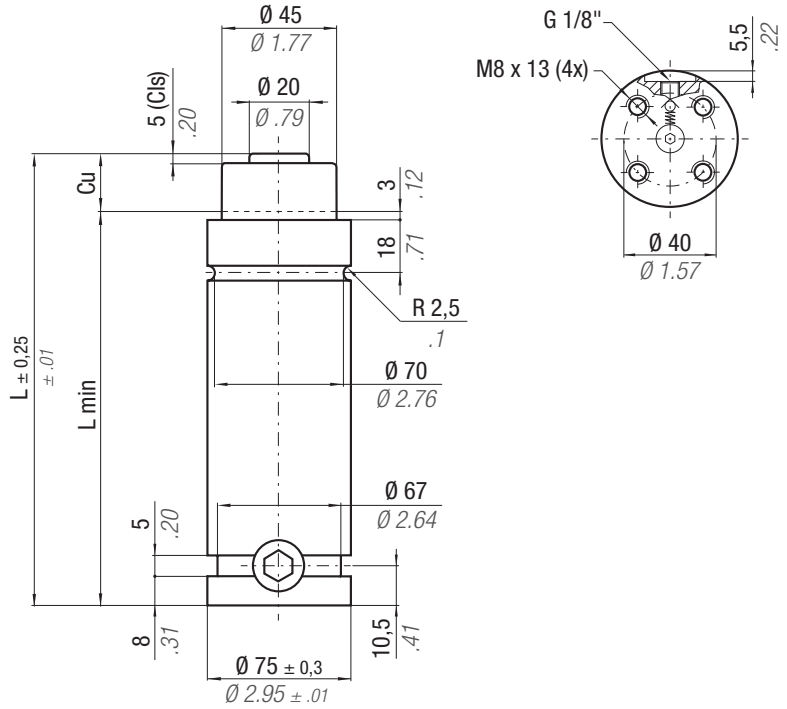

CODE	Cu		L		L min		F0		F Cls		F1i *		F1p **		Vo		Maintenance kit		
	mm	inch	mm	inch	mm	inch	daN	lb	daN	lb	daN	lb	daN	lb	cm ³	in ³	~Kg	~lb	
LS 1500 - 025 - A	25	0.98	160	6.30	135	5.31	0 ± 5%	0	1590	3574	2377	5344	2990	6722	129,0	7.87	3,71	8.18	✓
LS 1500 - 038 - A	38	1.50	186	7.32	148	5.83					2519	5663	3252	7311	176,0	10.74	3,79	8.36	✓
LS 1500 - 050 - A	50	1.97	210	8.27	160	6.30					2603	5852	3411	7668	219,0	13.36	3,89	8.58	✓
LS 1500 - 063 - A	63,5	2.50	237	9.33	173,5	6.83					2681	6027	3560	8002	265,0	16.17	4,48	9.88	✓
LS 1500 - 080 - A	80	3.15	270	10.63	190	7.48					2725	6126	3645	8195	326,0	19.89	4,73	10.43	✓
LS 1500 - 100 - A	100	3.94	310	12.20	210	8.27					2773	6234	3738	8403	398,0	24.28	4,89	10.78	✓
LS 1500 - 125 - A	125	4.92	360	14.17	235	9.25					2814	6326	3818	8583	488,0	29.77	5,57	12.28	✓
LS 1500 - 160 - A	160	6.30	430	16.93	270	10.63					2852	6412	3894	8753	614,0	37.45	6,33	13.96	✓
LS 1500 - 200 - A	200	7.87	510	20.08	310	12.20					2881	6477	3951	8881	757,0	46.18	7,19	15.85	✓
LS 1500 - 250 - A	250	9.84	610	24.02	360	14.17					2905	6531	3998	8989	937,0	57.16	9,19	20.26	✓
LS 1500 - 300 - A	300	11.81	710	27.95	410	16.14	2921	6567	4031	9063	1116,0	68.08	11,04	24.34	✓				

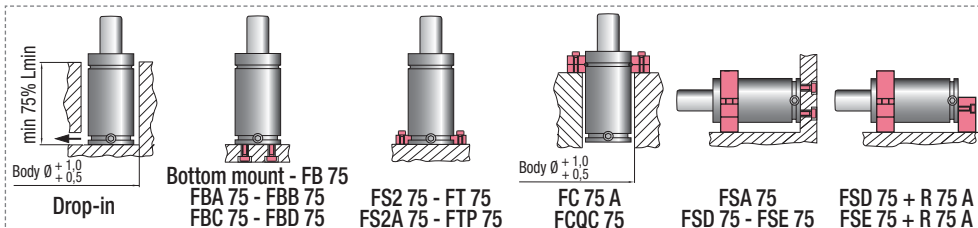

HOW TO ORDER

(10 pcs) LS 1500-050-A
(10 pcs) LS 1500-050-A-N

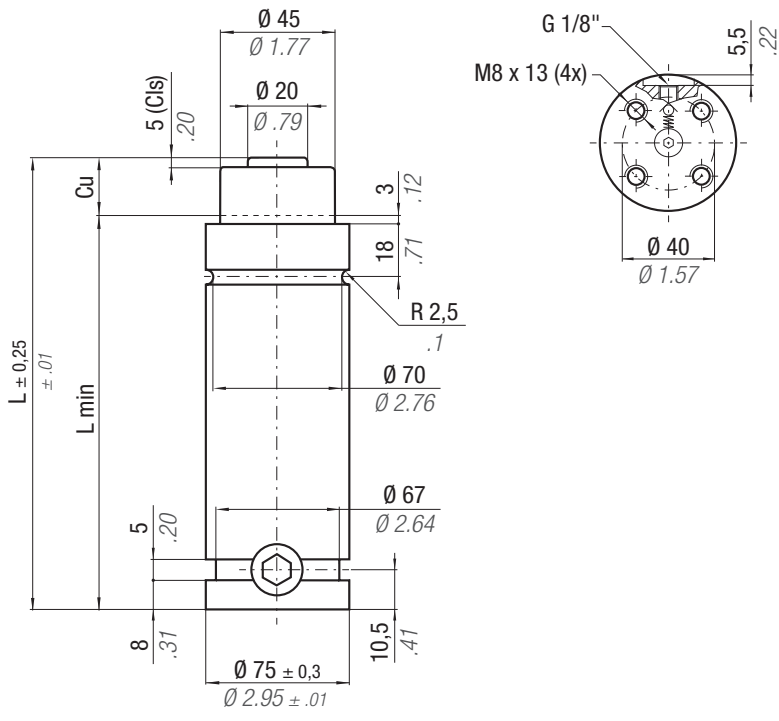

* $F_{1i} =$ Isothermal end force at 100% Cu
 ** $F_{1p} =$ Polytrophic end force at 100% Cu
 p. 16

ACTIVE SAFETY



	N ₂	°F 32 - 176	°C 0 - 80	ΔP $\pm 0,33\% / ^\circ C$	P max 150 bar 2175 psi	P min 20 bar 290 psi	S 15,9 cm ² 2.465 in ²	SPM ~ 15 - 60 (at 20°C)	Max Speed 1,8 m/s	Maintenance kit 39BMLS01500A
CODE	Cu	L	L min	F ₀ Initial force	F Cls	F _{1i} *	F _{1p} **	V ₀		
LS 2400 - 025 - A	25 0.98	160 6.30	135 5.31	0 0 $\pm 5\%$ 150 bar 2175 psi + 20 °C +68 °F	2385 5362 $\pm 5\%$ 150 bar 2175 psi + 20 °C +68 °F	4085 8428 4219 8617 4295 8790 4377 8931 4447 9052 4513 9164 4563 9249 4605 9320 4633 9369	5100 11465 5323 11875 5451 12253 5589 12564 5709 12834 5822 13088 5907 13280 5979 13441 6028 13551	129,0 7.87 176,0 10.74 219,0 13.36 265,0 16.17 326,0 19.89 398,0 24.28 488,0 29.77 614,0 37.45 757,0 46.18 937,0 57.16 1116,0 68.08	~Kg ~lb 3,71 8.18 3,79 8.36 3,89 8.58 4,48 9.88 4,73 10.43 4,89 10.78 5,57 12.28 6,33 13.96 7,19 15.85 9,19 20.26 11,04 24.34	2014/68/EU ✓ ✓ ✓ ✓ ✓ ✓ ✓ ✓ ✓ ✓ ✓
LS 2400 - 038 - A	38 1.50	186 7.32	148 5.83							
LS 2400 - 050 - A	50 1.97	210 8.27	160 6.30							
LS 2400 - 063 - A	63,5 2.50	237 9.33	173,5 6.83							
LS 2400 - 080 - A	80 3.15	270 10.63	190 7.48							
LS 2400 - 100 - A	100 3.94	310 12.20	210 8.27							
LS 2400 - 125 - A	125 4.92	360 14.17	235 9.25							
LS 2400 - 160 - A	160 6.30	430 16.93	270 10.63							
LS 2400 - 200 - A	200 7.87	510 20.08	310 12.20							
LS 2400 - 250 - A	250 9.84	610 24.02	360 14.17							
LS 2400 - 300 - A	300 11.81	710 27.95	410 16.14							

LS

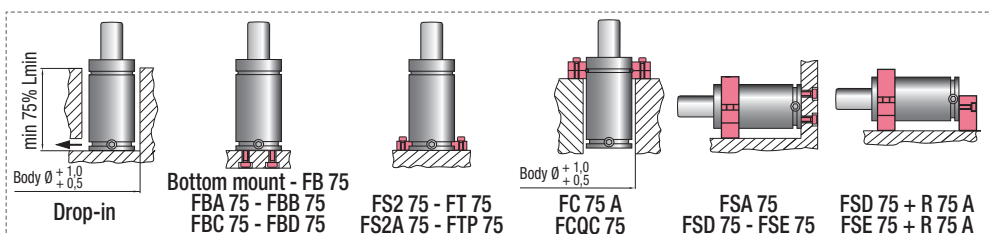

HOW TO ORDER

(10 pcs) LS 2400-050-A
 (10 pcs) LS 2400-050-A-N

ACTIVE SAFETY



* $F_{1i} =$ Isothermal end force at 100% Cu p. 16 Polytropic end force at 100% Cu

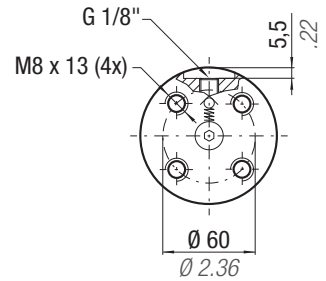
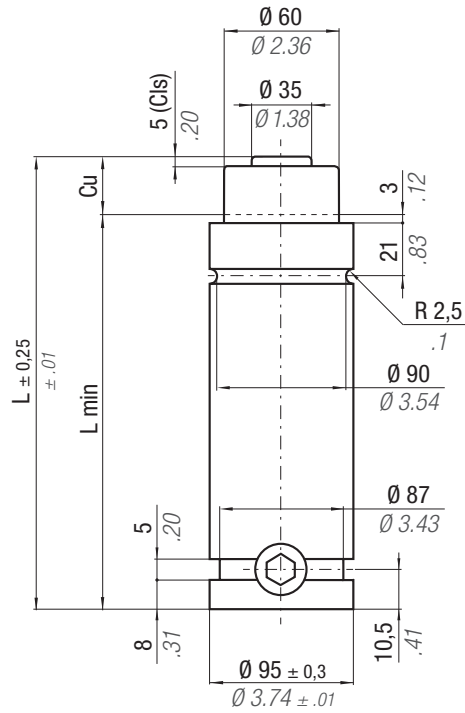

CODE	Cu		L		L min		F0		F Cis		F1i *		F1p **		Vo		Maintenance kit										
	mm	inch	mm	inch	mm	inch	daN	lb	daN	lb	daN	lb	daN	lb	cm ³	in ³	~Kg	~lb									
LS 3000 - 025 - A	25	0.98	170	6.69	145	5.71	0 ± 5%	0	2830	6362	4179	9395	5231	11759	235,0	14.34	5,69	12.54	39BMLS03000A								
LS 3000 - 038 - A	38	1.50	196	7.72	158	6.22														4510	10138	5841	13131	308,0	18.79	6,48	14.29
LS 3000 - 050 - A	50	1.97	220	8.66	170	6.69														4723	10619	6246	14042	377,0	23.00	6,77	14.93
LS 3000 - 063 - A	63,5	2.50	247	9.72	183,5	7.22														4923	11067	6632	14910	450,0	27.45	6,84	15.08
LS 3000 - 080 - A	80	3.15	280	11.02	200	7.87														5060	11376	6902	15516	547,0	33.37	7,23	15.94
LS 3000 - 100 - A	100	3.94	320	12.60	220	8.66														5200	11691	7181	16144	660,0	40.26	7,95	17.53
LS 3000 - 125 - A	125	4.92	370	14.57	245	9.65														5326	11973	7434	16712	802,0	48.92	9,58	21.12
LS 3000 - 160 - A	160	6.30	440	17.32	280	11.02														5447	12246	7681	17267	1001,0	61.06	10,89	24.01
LS 3000 - 200 - A	200	7.87	520	20.47	320	12.60														5541	12458	7874	17701	1228,0	74.91	11,03	24.32
LS 3000 - 250 - A	250	9.84	620	24.41	370	14.57														5622	12638	8040	18074	1511,0	92.17	12,06	26.59
LS 3000 - 300 - A	300	11.81	720	28.35	420	16.54	5678	12764	8156	18336	1795,0	109.50	13,02	28.70													

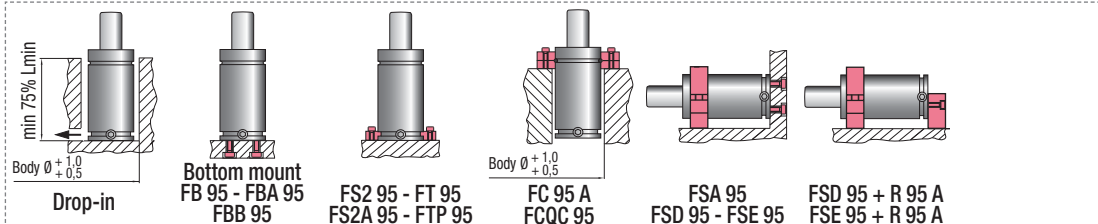

HOW TO ORDER

(10 pcs) LS 3000-050-A
(10 pcs) LS 3000-050-A-N

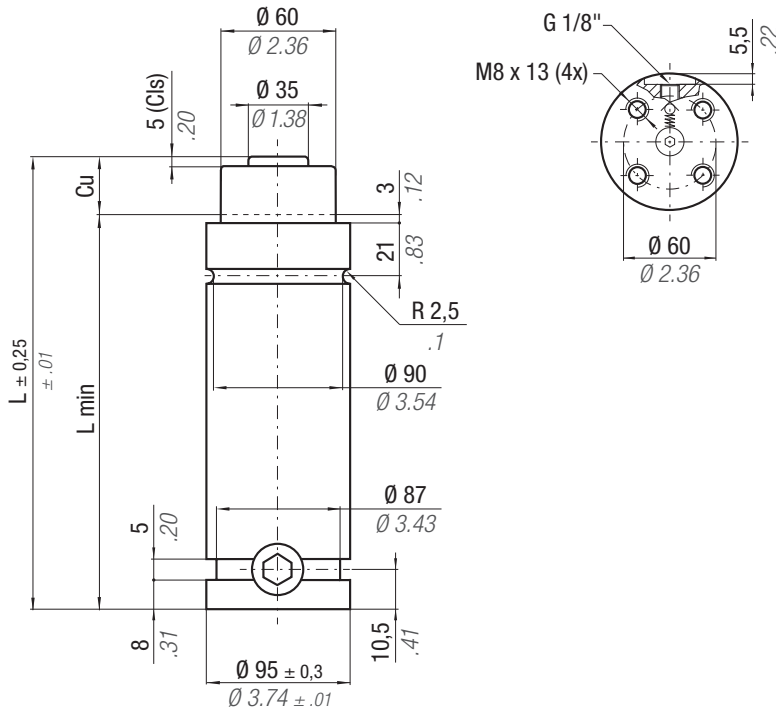

* $F_{1i} =$ Isothermal end force at 100% Cu
 ** $F_{1p} =$ Polytrophic end force at 100% Cu
 p. 16

ACTIVE SAFETY



	N ₂	°F 32 - 176	°C 0 - 80	ΔP $\pm 0,33\%/^{\circ}C$	P max 150 bar 2175 psi	P min 20 bar 290 psi	S 28,27 cm ² 4.382 in ²	SPM ~ 15 - 60 (at 20°C)	Max Speed 1,8 m/s	Maintenance kit 39BMLS03000A
CODE	Cu	L	L min	F ₀	F Cls	F _{1i} *	F _{1p} **	V ₀		
	mm inch	mm inch	mm inch	daN lb	daN lb	daN lb	daN lb	cm ³ in ³	~Kg ~lb	
LS 4200 - 025 - A	25 0.98	170 6.69	145 5.71	0 0 $\pm 5\%$ 150 bar 2175 psi + 20 °C +68 °F	4240 9532 $\pm 5\%$ 150 bar 2175 psi + 20 °C +68 °F	6498 14607	7821 17583	235,0 14.34	5,69 12.54	✓
LS 4200 - 038 - A	38 1.50	196 7.72	158 6.22			7060 15873	8733 19633	308,0 18.79	6,48 14.29	✓
LS 4200 - 050 - A	50 1.97	220 8.66	170 6.69			7427 16696	9340 20997	377,0 23.00	6,77 14.93	✓
LS 4200 - 063 - A	63,5 2.50	247 9.72	183,5 7.22			7770 17467	9917 22294	450,0 27.45	6,84 15.08	✓
LS 4200 - 080 - A	80 3.15	280 11.02	200 7.87			8006 17999	10320 23201	547,0 33.37	7,23 15.94	✓
LS 4200 - 100 - A	100 3.94	320 12.60	220 8.66			8249 18545	10738 24139	660,0 40.26	7,95 17.53	✓
LS 4200 - 125 - A	125 4.92	370 14.57	245 9.65			8467 19035	11116 24989	802,0 48.92	9,58 21.12	✓
LS 4200 - 160 - A	160 6.30	440 17.32	280 11.02			8678 19508	11485 25818	1001,0 61.06	10,89 24.01	✓
LS 4200 - 200 - A	200 7.87	520 20.47	320 12.60			8841 19876	11773 26467	1228,0 74.91	11,03 24.32	✓
LS 4200 - 250 - A	250 9.84	620 24.41	370 14.57			8981 20191	12021 27025	1511,0 92.17	12,06 26.59	✓
LS 4200 - 300 - A	300 11.81	720 28.35	420 16.54	9079 20411	12196 27417	1795,0 109.50	13,02 28.70	✓		

LS

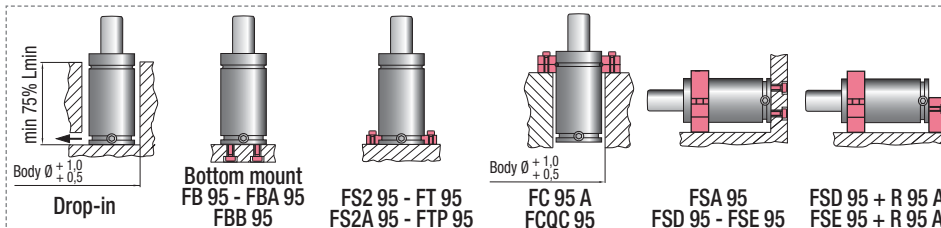

HOW TO ORDER

(10 pcs) LS 4200-050-A
 (10 pcs) LS 4200-050-A-N

ACTIVE SAFETY



* $F_{1i} =$ Isothermal end force at 100% Cu p. 16 Polytropic end force at 100% Cu $F_{1p} =$

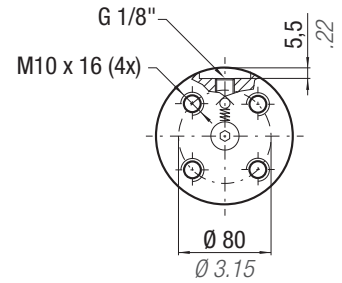
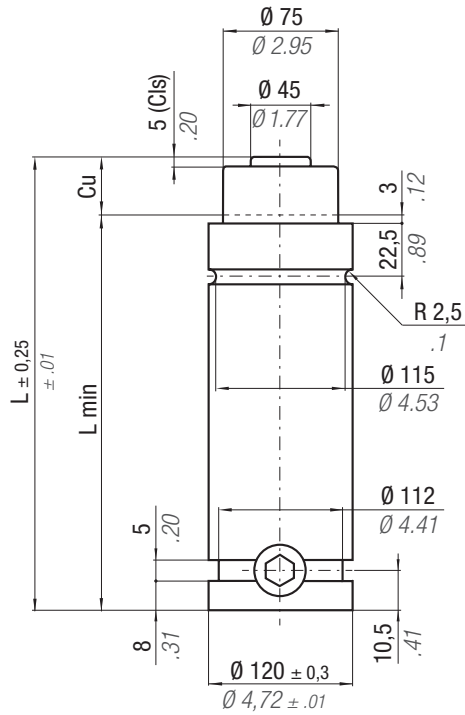

N ₂		°F 32 - 176	°C 0 - 80	ΔP ± 0,33 %/°C	P max 100 bar 1450 psi	P min 20 bar 290 psi	S 44,18 cm ² 6.848 in ²	SPM ~ 15 - 60 (at 20°C)	Max Speed 1,8 m/s	Maintenance kit 39BMLS05000A
CODE	Cu	L	L min	F ₀	F Cis	F _{1i} *	F _{1p} **	V ₀	PED 2014/68/EU	
	mm inch	mm inch	mm inch	daN lb	daN lb	daN lb	daN lb	cm ³ in ³	~Kg ~lb	✓
LS 5000 - 025 - A	25 0.98	190 7.48	165 6.50	0 ± 5%	4418 9932 ± 5%	6654 14958	8399 19241	353,0 21.53	10,60 23.37	✓
LS 5000 - 038 - A	38 1.50	216 8.50	178 7.01			7167 16111	9353 21427	468,0 28.55	12,00 26.46	✓
LS 5000 - 050 - A	50 1.97	240 9.45	190 7.48			7492 16842	9974 22850	575,0 35.08	13,20 29.10	✓
LS 5000 - 063 - A	63,5 2.50	267 10.51	203,5 8.01			7795 17523	10564 23997	691,0 42.15	13,60 29.98	✓
LS 5000 - 080 - A	80 3.15	300 11.81	220 8.66			7994 17970	10957 25102	842,0 51.36	14,10 31.09	✓
LS 5000 - 100 - A	100 3.94	340 13.39	240 9.45			8199 18433	11368 26044	1020,0 62.22	15,40 33.95	✓
LS 5000 - 125 - A	125 4.92	390 15.35	265 10.43			8382 18843	11737 26887	1243,0 75.82	16,90 37.26	✓
LS 5000 - 160 - A	160 6.30	460 18.11	300 11.81			8556 19235	12092 27703	1555,0 94.86	18,70 41.23	✓
LS 5000 - 200 - A	200 7.87	540 21.26	340 13.39			8690 19537	12369 28335	1911,0 116.57	21,70 47.84	✓
LS 5000 - 250 - A	250 9.84	640 25.20	390 15.35			8804 19793	12604 28875	2356,0 143.72	24,80 54.67	✓
LS 5000 - 300 - A	300 11.81	740 29.13	440 17.32	8884 19971	12769 29253	2801,0 170.86	28,00 61.73	✓		

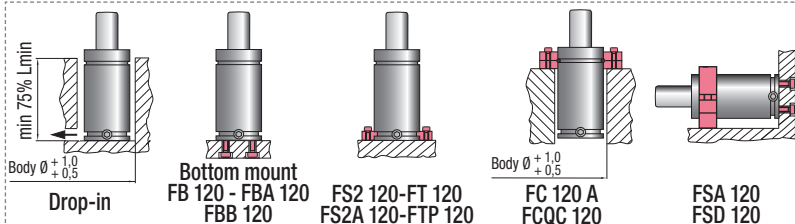

HOW TO ORDER

(10 pcs) LS 5000-050-A
(10 pcs) LS 5000-050-A-N

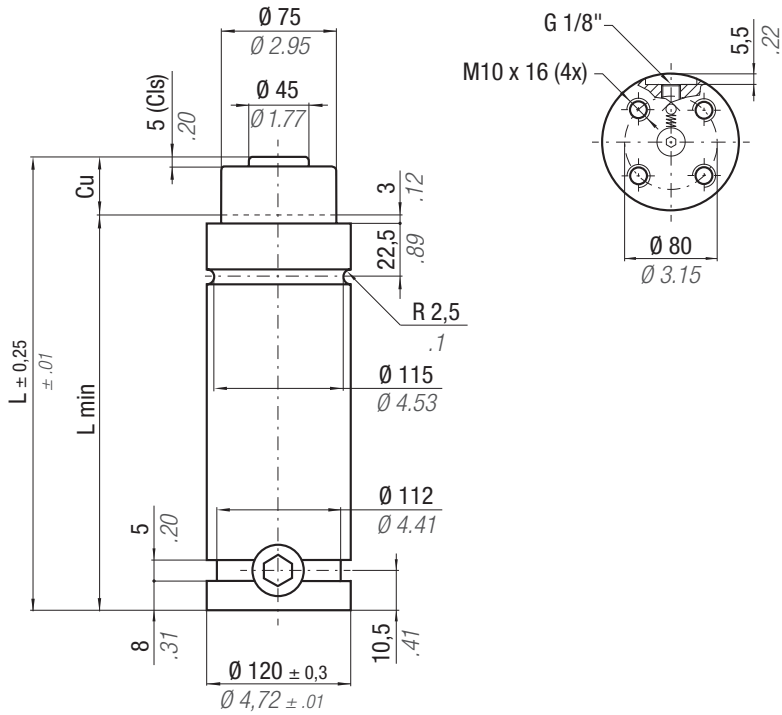

* F_{1i} = Isothermal end force at 100% Cu
 ** F_{1p} = Polytrophic end force at 100% Cu

p. 16

ACTIVE SAFETY



CODE	Cu		L		L min		F ₀		F Cls		F _{1i} *		F _{1p} **		V ₀		Maintenance kit		
	mm	inch	mm	inch	mm	inch	daN	lb	daN	lb	daN	lb	daN	lb	cm ³	in ³	~Kg	~lb	39BMLS05000A
LS 6600 - 025 - A	25	0.98	190	7.48	165	6.50	0 ± 5%	0	6630	14905	10363	23297	12558	28232	353,0	21.53	10,60	23.37	✓
LS 6600 - 038 - A	38	1.50	216	8.50	178	7.01					11238	25264	13985	31440	468,0	28.55	12,00	26.46	✓
LS 6600 - 050 - A	50	1.97	240	9.45	190	7.48					11796	26517	14914	33528	575,0	35.08	13,20	29.10	✓
LS 6600 - 063 - A	63,5	2.50	267	10.51	203.5	8.01					12317	27690	15796	35510	691,0	42.15	13,60	29.98	✓
LS 6600 - 080 - A	80	3.15	300	11.81	220	8.66					12661	28463	16384	36832	842,0	51.36	14,10	31.09	✓
LS 6600 - 100 - A	100	3.94	340	13.39	240	9.45					13017	29263	16998	38214	1020,0	62.22	15,40	33.95	✓
LS 6600 - 125 - A	125	4.92	390	15.35	265	10.43					13333	29974	17549	39452	1243,0	75.82	16,90	37.26	✓
LS 6600 - 160 - A	160	6.30	460	18.11	300	11.81					13637	30656	18081	40648	1555,0	94.86	18,70	41.23	✓
LS 6600 - 200 - A	200	7.87	540	21.26	340	13.39					13870	31182	18494	41576	1911,0	116.57	21,70	47.84	✓
LS 6600 - 250 - A	250	9.84	640	25.20	390	15.35					14069	31628	18846	42368	2356,0	143.72	24,80	54.67	✓
LS 6600 - 300 - A	300	11.81	740	29.13	440	17.32	14207	31939	19093	42922	2801,0	170.86	28,00	61.73	✓				

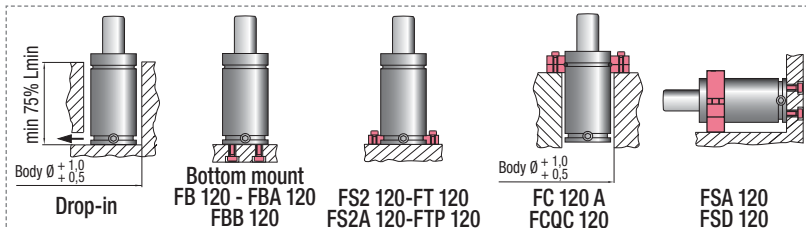

HOW TO ORDER

(10 pcs) LS 6600-050-A
 (10 pcs) LS 6600-050-A-N

Il nuovo codice sarà fornito solo ad esaurimento del vecchio

The new code will be supplied only when the old will be out of stock

Der neue Kode wird geliefert nur wenn der alte nicht mehr im Lager ist

Le nouveau code sera fourni uniquement lorsque le vieux stock sera écoulé

El nuevo código será suministrado sólo cuando el viejo está fuera de stock

O novo código irá ser fornecido apenas quando o antigo esgotar stock

ACTIVE SAFETY



OSAS



USAS



OPAS

* $F_{1i} =$

Isothermal end force at 100% Cu



p. 16



** $F_{1p} =$

Polytropic end force at 100% Cu

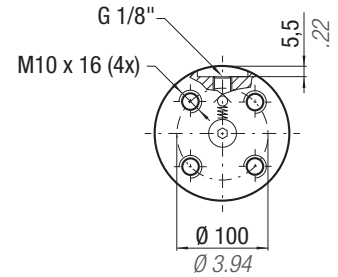
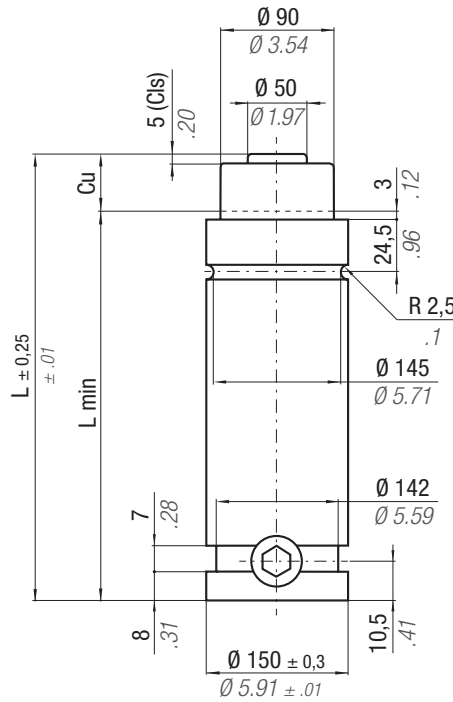

N ₂		°F 32 - 176	°C 0 - 80	ΔP ± 0,33 %/°C	P max 120 bar 1740 psi	P min 20 bar 290 psi	S 63,61 cm ² 9.860 in ²	SPM ~ 15 - 60 (at 20°C)	Max Speed 1,8 m/s	Maintenance kit 39BMLS07500A	
CODE	NEW	Cu	L	L min	F ₀	F Cls	F _{1i} *	F _{1p} **	V ₀		PED
PHASING OUT from	NEW	mm inch	mm inch	mm inch	Initial force daN lb	F Cls daN lb	End force * daN lb	End force ** daN lb	cm ³ in ³	~Kg ~lb	2014/68/EU
LS 7500-025-A	LS 7500-025-B	25 0.98	205 8.07	180 7.09			10207 22946	11937 26835	594,0 36.23	19,95 43.98	✓
LS 7500-038-A	LS 7500-038-B	38 1.50	231 9.09	193 7.60			10950 24617	13169 29605	797,0 48.62	21,15 46.63	✓
LS 7500-050-A	LS 7500-050-B	50 1.97	255 10.04	205 8.07	0 0	7630 17152	11460 25763	14034 31550	784,0 47.82	21,95 48.39	✓
LS 7500-063-A	LS 7500-063-B	63,5 2.50	282 11.10	218,5 8.60	± 5%	± 5%	11901 26755	14795 33260	1195,0 72.90	22,75 50.16	✓
LS 7500-080-A	LS 7500-080-B	80 3.15	315 12.40	235 9.25			12313 27681	15515 34879	1452,0 88.57	24,55 54.12	✓
LS 7500-100-A	LS 7500-100-B	100 3.94	355 13.98	255 10.04	120 bar 1740 psi	120 bar 1740 psi	12688 28524	16181 36376	1764,0 107.60	26,25 57.87	✓
LS 7500-125-A	LS 7500-125-B	125 4.92	405 15.94	280 11.02			13034 29302	16801 37770	2153,0 131.33	28,15 62.06	✓
LS 7500-160-A	LS 7500-160-B	160 6.30	475 18.70	315 12.40	+ 20 °C +68 °F	+ 20 °C +68 °F	13379 30077	17425 39173	2699,0 164.64	31,55 69.56	✓
LS 7500-200-A	LS 7500-200-B	200 7.87	555 21.85	355 13.98			13653 30693	14926 33555	3323,0 202.70	35,15 77.49	✓
LS 7500-250-A	LS 7500-250-B	250 9.84	655 25.79	405 15.94			13891 31228	18365 41286	4102,0 250.22	38,65 85.21	✓
LS 7500-300-A	LS 7500-300-B	300 11.81	755 29.72	455 17.91			14061 31610	18680 41994	4882,0 297.80	42,55 93.81	✓

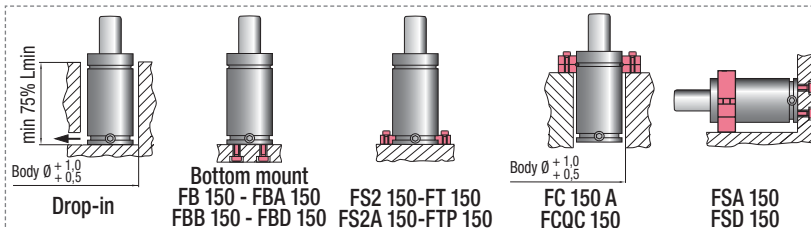

HOW TO ORDER

(10 pcs) LS 7500-050-A
(10 pcs) LS 7500-050-A-N

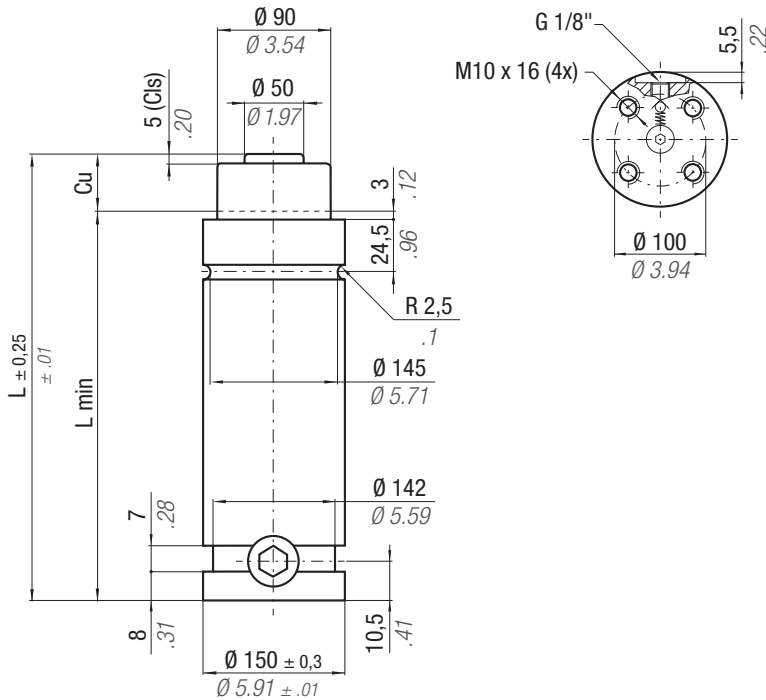

Il nuovo codice sarà fornito solo ad esaurimento del vecchio

The new code will be supplied only when the old will be out of stock

Der neue Kode wird geliefert nur wenn der alte nicht mehr im Lager ist

Le nouveau code sera fourni uniquement lorsque le vieux stock sera écoulé

El nuevo código será suministrado sólo cuando el viejo está fuera de stock

O novo código irá ser fornecido apenas quando o antigo esgotar stock

* $F_{1i} =$

Isothermal end force at 100% Cu

p. 16

** $F_{1p} =$

Polytrophic end force at 100% Cu

ACTIVE SAFETY



OSAS



USAS



OPAS

		$^{\circ}F$ 32 176	$^{\circ}C$ 0 80	ΔP $\pm 0,33 \% / ^{\circ}C$	P max 150 bar 2175 psi	P min 20 bar 290 psi	S 63,61 cm ² 9.860 in ²	SPM ~ 15 - 60 (at 20°C)	Max Speed 1,8 m/s	Maintenance kit 39BMLS07500A	
CODE PHASING OUT from	NEW	C_u	L	$L min$	F_0	$F Cis$	$F_{1i} *$	$F_{1p} **$	V_0		
		mm inch	mm inch	mm inch	daN lb	daN lb	daN lb	daN lb	cm ³ in ³	~Kg ~lb	2014/68/EU
LS 9500 - 025 - A	LS 9500 - 025 - B	25 0.98	205 8.07	180 7.09	0 0 $\pm 5\%$ 150 bar 2175 psi + 20 °C +68 °F	9540 21446 $\pm 5\%$ 150 bar 2175 psi + 20 °C +68 °F	10207 22946	11937 26835	594,0 36.23	19,95 43.98	✓
LS 9500 - 038 - A	LS 9500 - 038 - B	38 1.50	231 9.09	193 7.60			10950 24617	13169 29605	797,0 48.62	21,15 46.63	✓
LS 9500 - 050 - A	LS 9500 - 050 - B	50 1.97	255 10.04	205 8.07			11460 25763	14034 31550	784,0 47.82	21,95 48.39	✓
LS 9500 - 063 - A	LS 9500 - 063 - B	63,5 2.50	282 11.10	218.5 8.60			11901 26755	14795 33260	1195,0 72.90	22,75 50.16	✓
LS 9500 - 080 - A	LS 9500 - 080 - B	80 3.15	315 12.40	235 9.25			12313 27681	15515 34879	1452,0 88.57	24,55 54.12	✓
LS 9500 - 100 - A	LS 9500 - 100 - B	100 3.94	355 13.98	255 10.04			12688 28524	16181 36376	1764,0 107.60	26,25 57.87	✓
LS 9500 - 125 - A	LS 9500 - 125 - B	125 4.92	405 15.94	280 11.02			13034 29302	16801 37770	2153,0 131.33	28,15 62.06	✓
LS 9500 - 160 - A	LS 9500 - 160 - B	160 6.30	475 18.70	315 12.40			13379 30077	17425 39173	2699,0 164.64	31,55 69.56	✓
LS 9500 - 200 - A	LS 9500 - 200 - B	200 7.87	555 21.85	355 13.98			13653 30693	14926 33555	3323,0 202.70	35,15 77.49	✓
LS 9500 - 250 - A	LS 9500 - 250 - B	250 9.84	655 25.79	405 15.94			13891 31228	18365 41286	4102,0 250.22	38,65 85.21	✓
LS 9500 - 300 - A	LS 9500 - 300 - B	300 11.81	755 29.72	455 17.91	14061 31610	18680 41994	4882,0 297.80	42,55 93.81	✓		

LS

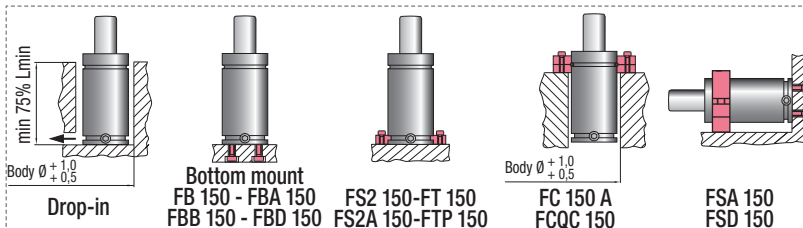

HOW TO ORDER

(10 pcs) LS 9500-050-A
(10 pcs) LS 9500-050-A-N

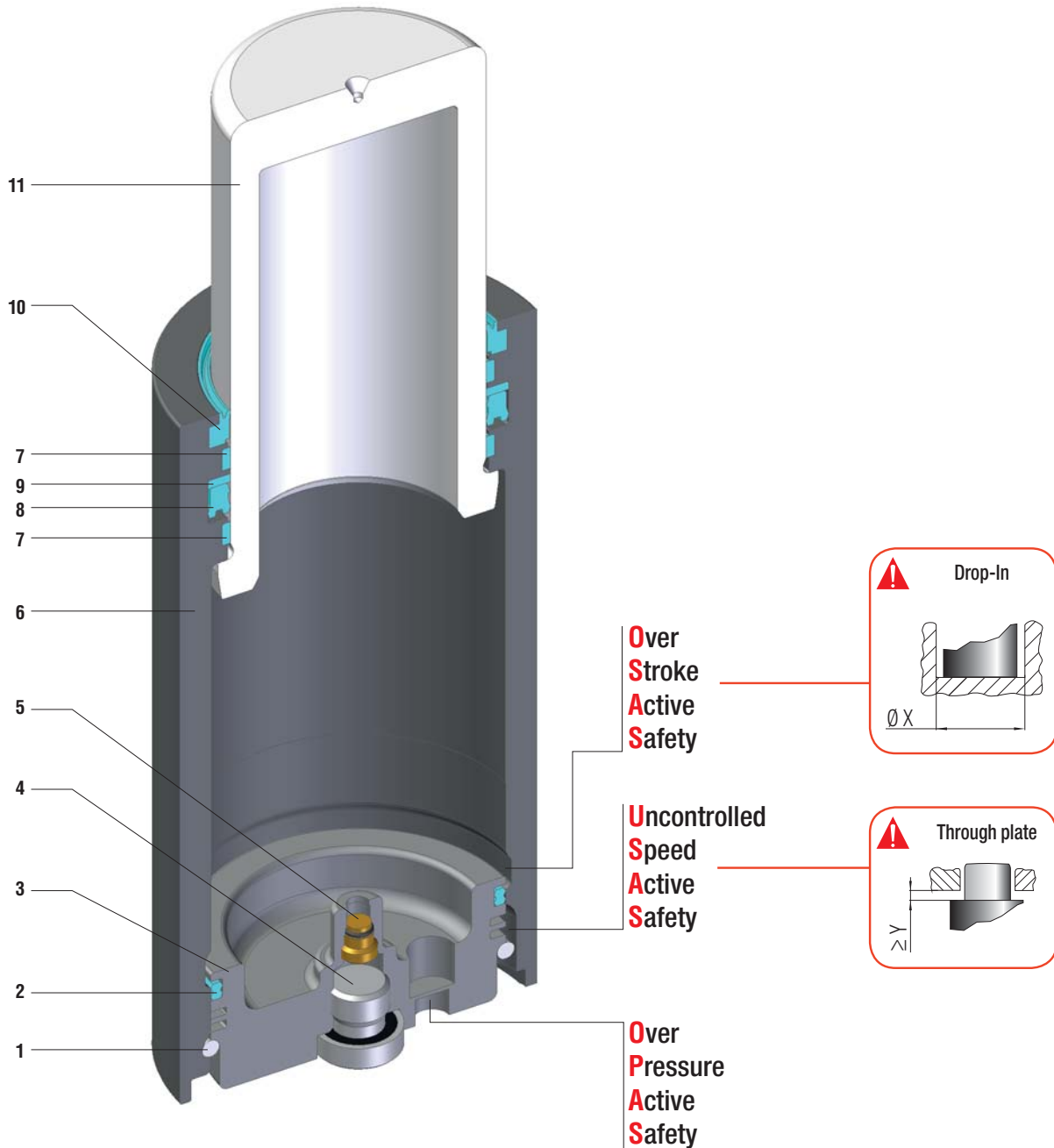

Massima forza, tenuta stelo - Maximum force, rod sealed - Maximale Kraft, Kolbenstange dichtung
 Forces maximale, joint de tige - Máxima fuerza, estanqueidad vástago - Força máxima, estanquidade na haste

SEALING	ROD SEAL
DESIGN	BOTTOM BASE - BODY DESIGN

1	Retaining ring	5	Valve	9	Back-up ring
2	Dual ring seal	6	Body	10	Rod wiper
3	Bottom base	7	Guide ring	11	Rod (nitrited superfinished)
4	Plug	8	Rod seal		

RANGE CHART

Model	Body Ø		Stroke Cu		Initial force F0					
	mm	inch	mm	inch	daN	lb				
ML 300	25	0.98	10 - 80	0.39 - 3.15	310	697	✓	✓	-	-
ML 500	32	1.26	10 - 80	0.39 - 3.15	510	1147	✓	✓	-	-
ML 1000	38	1.50	10 - 80	0.39 - 3.15	980	2203	✓	✓	✓	-
ML 1000 N	38	1.50	10 - 80	0.39 - 3.15	980	2203	✓	✓	✓	-
ML 1800	50	1.97	15 - 80	0.59 - 3.15	1925	4327	✓	✓	✓	-
ML 1800 N	50	1.97	15 - 80	0.59 - 3.15	1925	4327	✓	✓	✓	-
ML 3000	63	2.48	15 - 80	0.59 - 3.15	3180	11071	✓	✓	✓	-
ML 3000 N	63	2.48	15 - 80	0.59 - 3.15	3180	11071	✓	✓	✓	-
ML 4700	75	2.95	15 - 80	0.59 - 3.15	4925	11071	✓	✓	✓	-
ML 4700 N	75	2.95	15 - 80	0.59 - 3.15	4925	11071	✓	✓	✓	-
ML 7500	95	3.74	15 - 80	0.59 - 3.15	7700	17310	✓	✓	✓	-
ML 7500 N	95	3.74	15 - 80	0.59 - 3.15	7700	17310	✓	✓	✓	-
ML 12000	120	4.72	15 - 80	0.59 - 3.15	12720	28595	✓	✓	✓	-
ML 12000 N	120	4.72	15 - 80	0.59 - 3.15	12720	28595	✓	✓	✓	-

HOW TO ORDER

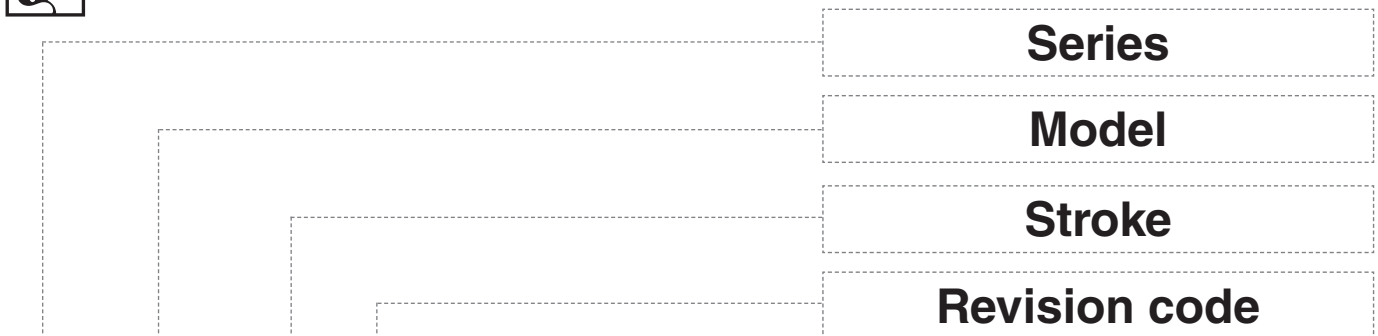

ML 1800-050-C - N - E

- IT** Codice cilindro autonomo
- EN** Self-contained cylinder code
- DE** Kode des eingeständigen Gdf.
- FR** Code du cylindre autonome
- ES** Código del cilindro autónomo
- PT** Código do cilindro autónomo

- IT** Collegabile con tubi, fornito scarico e senza valvola unidirezionale, L+20 mm
- EN** Linkable with hoses, supplied without pressure and oneway valve, L+20 mm
- DE** Anschlussfähig mit Leitungen, geliefert ohne Druck und RückschlagVentil, L+20 mm
- FR** Connectable avec tubes, fourni sans pression ni valve unidirectionelle, L+20 mm
- ES** Connectable con tubos, suministrado sin presión y sin válvula unidireccional, L+20 mm
- PT** Acompláveis com tubos, fornecidos sem pressão e sem válvula unidireccional, L+20 mm

- IT** Collegabile EASY MANIFOLD, fornito scarico senza valvola + NIPPLE di collegamento
- EN** Linkable EASY MANIFOLD, supplied without pressure and valve + NIPPLE connecting
- DE** Anschlussfähig EASY MANIFOLD, geliefert ohne Druck und ohne Ventil + NIPPEL Verbindungs
- FR** Connectable EASY MANIFOLD, fourni sans pression ni valve + NIPPLE de connexion
- ES** Connectable EASY MANIFOLD, suministrado sin presión y sin válvula + NIPLE de conexión
- PT** Acompláveis EASY MANIFOLD, fornecidos sem pressão e sem válvula + LIGACÃO INTERIOR de conexão

ACTIVE SAFETY



OSAS



USAS

Il nuovo codice sarà fornito solo ad esaurimento del vecchio

The new code will be supplied only when the old will be out of stock

Der neue Kode wird geliefert nur wenn der alte nicht mehr im Lager ist

Le nouveau code sera fourni uniquement lorsque le vieux stock sera écoulé

El nuevo código será suministrado sólo cuando el viejo está fuera de stock

O novo código irá ser fornecido apenas quando o antigo esgotar stock

* $F_{1i} =$

Isothermal end force at 100% Cu



p. 16



** $F_{1p} =$

Polytrophic end force at 100% Cu

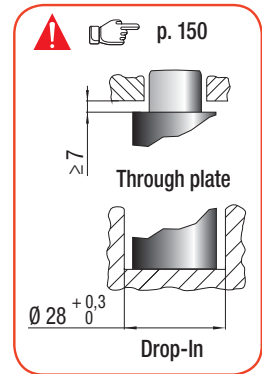
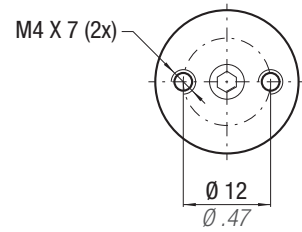
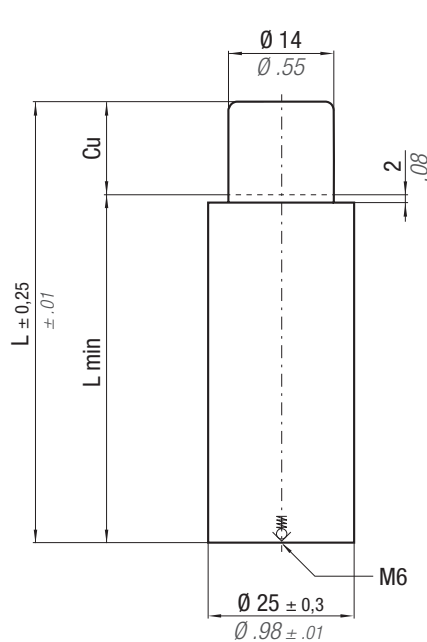

CODE PHASING OUT from 04/2013	NEW	Cu		L		L min		F ₀ Initial force daN lb	S 1,54 cm ² 0.239 in ²	SPM ~ 40 - 80 (at 20°C)	Max Speed 1,6 m/s	Maintenance kit Disposable	PED 2014/68/EU		
		mm	inch	mm	inch	mm	inch								
ML 300 - 010 - B	ML 300 - 010 - C	10	0.39	75	2.95	65	2.56	310 697 ± 5%	200 bar 2900 psi	+20 °C +68 °F	424 954	476 1070	7,0 0.43	0,17 0.37	✓
ML 300 - 015 - B	ML 300 - 015 - C	15	0.59	85	3.35	70	2.76								
ML 300 - 025 - B	ML 300 - 025 - C	25	0.98	105	4.13	80	3.15	509 1143	592 1331	12,0 0.73	0,21 0.46	✓			
ML 300 - 038 - B	ML 300 - 038 - C	38	1.50	130	5.12	92	3.62	555 1248	658 1479	16,0 0.98	0,24 0.53	✓			
ML 300 - 050 - B	ML 300 - 050 - C	50	1.97	155	6.10	105	4.13	572 1286	682 1533	20,0 1.22	0,27 0.60	✓			
ML 300 - 063 - B	ML 300 - 063 - C	63	2.48	185	7.28	122	4.80	569 1279	678 1524	26,0 1.59	0,31 0.68	✓			
ML 300 - 080 - B	ML 300 - 080 - C	80	3.15	220	8.66	140	5.51	584 1313	699 1571	32,0 1.95	0,35 0.77	✓			

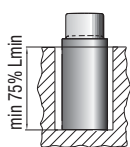

Drop-In



Bottom mount



HOW TO ORDER

(10 pcs) ML300-050-C

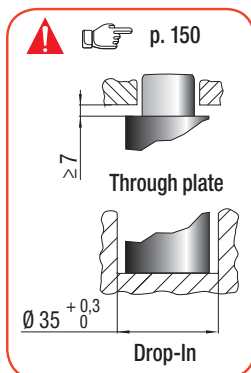
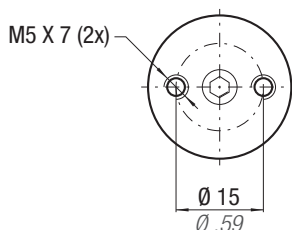
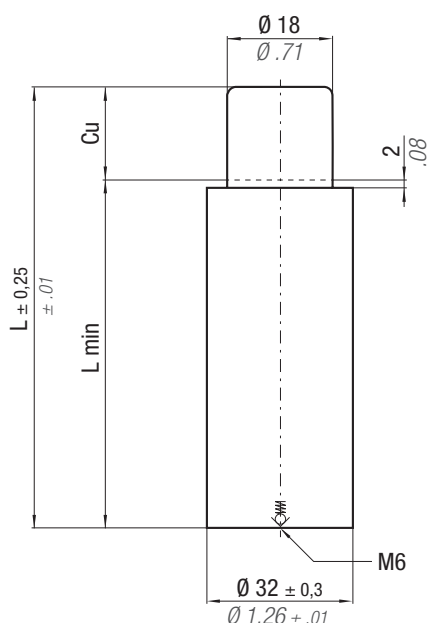

Il nuovo codice sarà fornito solo ad esaurimento del vecchio

The new code will be supplied only when the old will be out of stock

Der neue Kode wird geliefert nur wenn der alte nicht mehr im Lager ist

Le nouveau code sera fourni uniquement lorsque le vieux stock sera écoulé

El nuevo código será suministrado sólo cuando el viejo está fuera de stock

O novo código irá ser fornecido apenas quando o antigo esgotar stock

ACTIVE SAFETY



OSAS



USAS

* $F_{1i} =$

Isothermal end force at 100% Cu



p. 16



** $F_{1p} =$

Polytrophic end force at 100% Cu

N ₂		°F 32 - 176	°C 0 - 80	ΔP ± 0,33 %/°C	P max 200 bar 2900 psi	P min 20 bar 290 psi	S 2,54 cm ² 0.394 in ²	SPM ~ 40 - 80 (at 20°C)	Max Speed 1,6 m/s	Maintenance kit Disposable								
CODE	NEW	Cu		L		L min		F ₀		F _{1i} *		F _{1p} **		V ₀		PED		
PHASING OUT from 04/2013		mm	inch	mm	inch	mm	inch	daN	lb	daN	lb	daN	lb	cm ³	in ³	~Kg	~lb	2014/68/EU
ML 500 - 010 - B	ML 500 - 010 - C	10	0.39	75	2.95	65	2.56	510	1147	708	1592	796	1789	11,0	0.67	0,28	0.62	✓
ML 500 - 015 - B	ML 500 - 015 - C	15	0.59	85	3.35	70	2.76	± 5%		763	1715	871	1958	14,0	0.85	0,30	0.66	✓
ML 500 - 025 - B	ML 500 - 025 - C	25	0.98	105	4.13	80	3.15	200 bar 2900 psi		835	1877	971	2183	20,0	1.22	0,34	0.75	✓
ML 500 - 038 - B	ML 500 - 038 - C	38	1.50	130	5.12	92	3.62			902	2028	1065	2394	27,0	1.65	0,39	0.86	✓
ML 500 - 050 - B	ML 500 - 050 - C	50	1.97	155	6.10	105	4.13			923	2075	1095	2462	35,0	2.14	0,43	0.95	✓
ML 500 - 063 - B	ML 500 - 063 - C	63	2.48	190	7.48	127	5.00			881	1981	1035	2327	47,0	2.87	0,51	1.12	✓
ML 500 - 080 - B	ML 500 - 080 - C	80	3.15	225	8.86	145	5.71	+20 °C +68 °F		904	2032	1069	2403	57,0	3.48	0,57	1.26	✓

ML

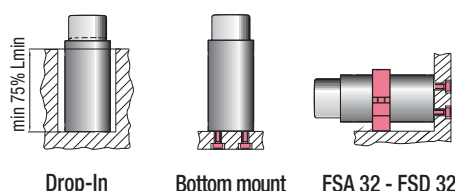

HOW TO ORDER

(10 pcs) ML500-050-C

Il nuovo codice sarà fornito solo ad esaurimento del vecchio

The new code will be supplied only when the old will be out of stock

Der neue Kode wird geliefert nur wenn der alte nicht mehr im Lager ist

Le nouveau code sera fourni uniquement lorsque le vieux stock sera écoulé

El nuevo código será suministrado sólo cuando el viejo está fuera de stock

O novo código irá ser fornecido apenas quando o antigo esgotar stock

ACTIVE SAFETY



OSAS



USAS



OPAS

* $F_{1i} =$

Isothermal end force at 100% Cu



p. 16



** $F_{1p} =$

Polytropic end force at 100% Cu

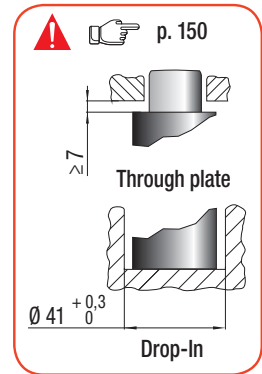
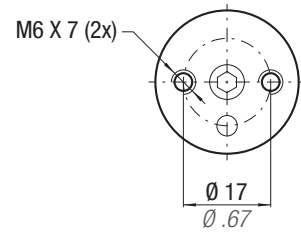
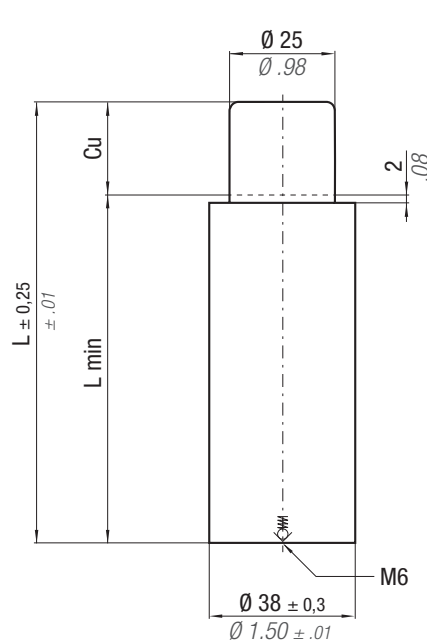

N ₂		°F 32 -176	°C 0 -80	ΔP ± 0,33 %/°C	P max 200 bar 2900 psi	P min 20 bar 290 psi	S 4,91 cm ² 0.761 in ²	SPM ~ 40 - 80 (at 20°C)	Max Speed 1,6 m/s	Maintenance kit 39BMML01000C
CODE	NEW	Cu	L	L min	F ₀	F _{1i} *	F _{1p} **	V ₀	PED 2014/68/EU	
PHASING OUT from 04/2013		mm inch	mm inch	mm inch	Initial force daN lb	End force * daN lb	End force ** daN lb	cm ³ in ³	~Kg ~lb	✓
ML 1000 - 010 - B	ML 1000 - 010 - C	10 0.39	75 2.95	65 2.56	980 2203 ± 5%	1371 3081	1542 3467	22,0 1.34	0,37 0.82	✓
ML 1000 - 015 - B	ML 1000 - 015 - C	15 0.59	85 3.35	70 2.76		1500 3372	1719 3864	27,0 1.65	0,39 0.86	✓
ML 1000 - 025 - B	ML 1000 - 025 - C	25 0.98	105 4.13	80 3.15	200 bar 2900 psi	1687 3793	1981 4453	36,0 2.20	0,45 0.99	✓
ML 1000 - 038 - B	ML 1000 - 038 - C	38 1.50	135 5.31	97 3.82		1768 3974	2095 4710	52,0 3.17	0,53 1.17	✓
ML 1000 - 050 - B	ML 1000 - 050 - C	50 1.97	160 6.30	110 4.33	+20 °C +68 °F	1854 4169	2220 4991	64,0 3.90	0,60 1.32	✓
ML 1000 - 063 - B	ML 1000 - 063 - C	63 2.48	205 8.07	142 5.59		1708 3839	2010 4519	90,0 5.49	0,73 1.61	✓
ML 1000 - 080 - B	ML 1000 - 080 - C	80 3.15	240 9.45	160 6.30		1790 4024	2127 4782	107,0 6.53	0,82 1.81	✓

FML 1000

code: 39FML01000B

Kit speciale per trasformare cilindri autonomi
 Special kit to convert self-contained cylinders
 Spezial-Set zum Umbau eigenständiger Zylinder
 Kit spécial pour transformer les cylindres autonomes
 Kit especial para transformar cilindros autónomos
 Kit especial para transformar cilindros autónomos

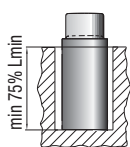
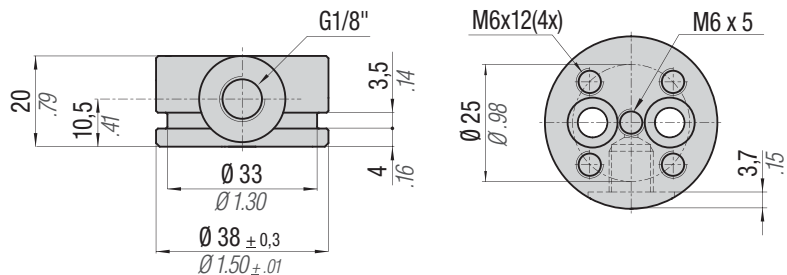

Drop-In



Bottom mount

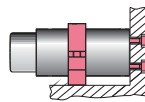

FSA 38 - FSD 38

HOW TO ORDER

(10 pcs) ML1000-050-C

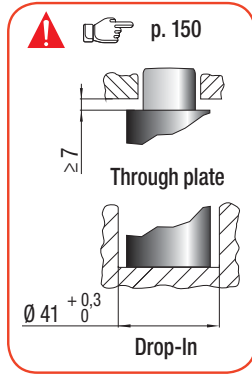
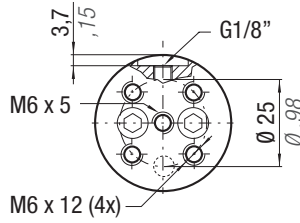
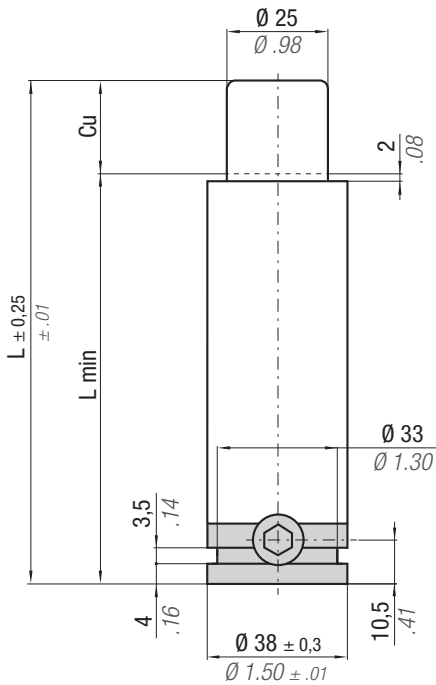

Il nuovo codice sarà fornito solo ad esaurimento del vecchio

The new code will be supplied only when the old will be out of stock

Der neue Kode wird geliefert nur wenn der alte nicht mehr im Lager ist

Le nouveau code sera fourni uniquement lorsque le vieux stock sera écoulé

El nuevo código será suministrado sólo cuando el viejo está fuera de stock

O novo código irá ser fornecido apenas quando o antigo esgotar stock

ACTIVE SAFETY



OSAS



USAS



OPAS

* $F_{1i} =$

Isothermal end force at 100% Cu



p. 16



** $F_{1p} =$

Polytrophic end force at 100% Cu

N ₂		°F 32 - 176	°C 0 - 80	ΔP ± 0,33%/°C	P max 200 bar 2900 psi	P min 20 bar 290 psi	S 4,91 cm ² 0.761 in ²	SPM ~ 40 - 80 (at 20°C)	Max Speed 1,6 m/s	Maintenance kit 39BMMML01000C								
CODE	NEW	Cu		L		L min		F ₀		F _{1i} *		F _{1p} **		V ₀		PED		
PHASING OUT from 04/2013		mm	inch	mm	inch	mm	inch	daN	lb	daN	lb	daN	lb	cm ³	in ³	~Kg	~lb	2014/68/EU
ML1000-010-B-N	ML1000-010-C-N	10	0.39	95	3.74	85	3.35	980	2203	1371	3081	1542	3467	22,0	1.34	0,52	1.15	✓
ML1000-015-B-N	ML1000-015-C-N	15	0.59	105	4.13	90	3.54	± 5%		1500	3372	1719	3864	27,0	1.65	0,55	1.21	✓
ML1000-025-B-N	ML1000-025-C-N	25	0.98	125	4.92	100	3.94	200 bar		1687	3793	1981	4453	36,0	2.20	0,60	1.32	✓
ML1000-038-B-N	ML1000-038-C-N	38	1.50	155	6.10	117	4.61	2900 psi		1768	3974	2095	4710	52,0	3.17	0,68	1.50	✓
ML1000-050-B-N	ML1000-050-C-N	50	1.97	180	7.09	130	5.12			1854	4169	2220	4991	64,0	3.90	0,75	1.65	✓
ML1000-063-B-N	ML1000-063-C-N	63	2.48	225	8.86	162	6.38			1708	3839	2010	4519	90,0	5.49	0,88	1.94	✓
ML1000-080-B-N	ML1000-080-C-N	80	3.15	260	10.24	180	7.09	+20 °C +68 °F		1790	4024	2127	4782	107,0	6.53	0,98	2.16	✓

ML

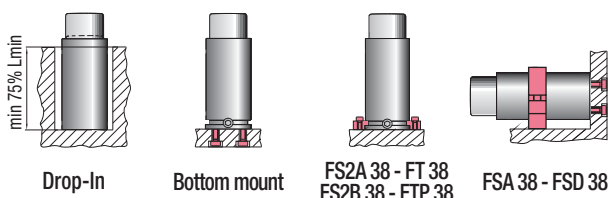

HOW TO ORDER

(10 pcs) ML1000-050-C-N

ACTIVE SAFETY



OSAS



USAS



OPAS

Il nuovo codice sarà fornito solo ad esaurimento del vecchio

The new code will be supplied only when the old will be out of stock

Der neue Kode wird geliefert nur wenn der alte nicht mehr im Lager ist

Le nouveau code sera fourni uniquement lorsque le vieux stock sera écoulé

El nuevo código será suministrado sólo cuando el viejo está fuera de stock

O novo código irá ser fornecido apenas quando o antigo esgotar stock

easu MANIFOLD p. 211

* $F_{1i} =$

Isothermal end force at 100% Cu p. 16

** $F_{1p} =$

Polytrophic end force at 100% Cu

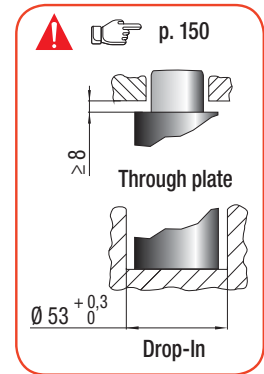
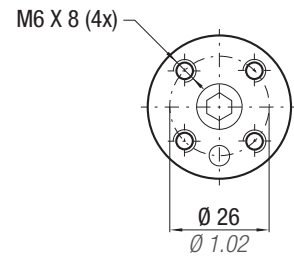
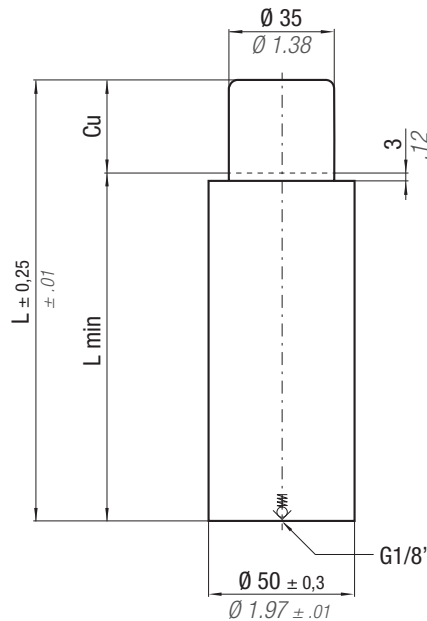

N ₂		°F 32 - 176	°C 0 - 80	ΔP ± 0,33 %/°C	P max 200 bar 2900 psi	P min 20 bar 290 psi	S 9,62 cm ² 1.491 in ²	SPM ~ 40 - 80 (at 20°C)	Max Speed 1,6 m/s	Maintenance kit 39BMML01800C								
CODE	NEW	Cu		L		L min		F ₀	F _{1i} *	F _{1p} **	V ₀							
PHASING OUT from 04/2013		mm	inch	mm	inch	mm	inch	daN	lb	daN	lb	daN		lb	cm ³	in ³	~Kg	~lb
ML 1800 - 015 - B	ML 1800 - 015 - C	15	0.59	95	3.74	80	3.15	1925	4327	2818	6334	3200	7194	57,0	3.48	0,76	1.68	✓
ML 1800 - 025 - B	ML 1800 - 025 - C	25	0.98	115	4.53	90	3.54	± 5%		3182	7154	3706	8331	75,0	4.58	0,85	1.87	✓
ML 1800 - 038 - B	ML 1800 - 038 - C	38	1.50	150	5.91	112	4.41	200 bar		3257	7321	3811	8567	111,0	6.77	1,01	2.23	✓
ML 1800 - 050 - B	ML 1800 - 050 - C	50	1.97	175	6.89	125	4.92	2900 psi		3451	7758	4087	9188	134,0	8.17	1,12	2.47	✓
ML 1800 - 063 - B	ML 1800 - 063 - C	63	2.48	205	8.07	142	5.59	+20 °C +68 °F		3546	7972	4224	9496	163,0	9.94	1,26	2.78	✓
ML 1800 - 080 - B	ML 1800 - 080 - C	80	3.15	245	9.65	165	6.50			3619	8136	4329	9732	201,0	12.26	1,44	3.17	✓

FML 1800

code: 39FML01800A

Kit speciale per trasformare cilindri autonomi
 Special kit to convert self-contained cylinders
 Spezial-Set zum Umbau eigenständiger Zylinder
 Kit spécial pour transformer les cylindres autonomes
 Kit especial para transformar cilindros autónomos
 Kit especial para transformar cilindros autónomos

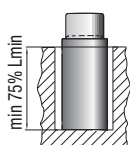
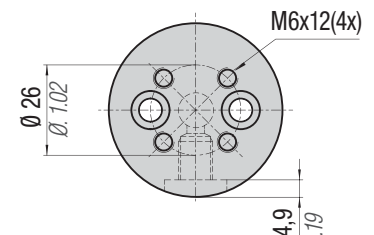
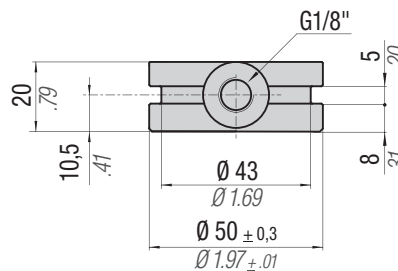

Drop-In



Bottom mount

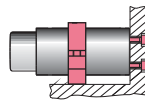

FSA 50 - FSD 50
FSE 50

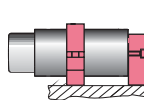

FSD 50 + R 50 A
FSE 50 + R 50 A

HOW TO ORDER

(10 pcs) ML1800-050-C

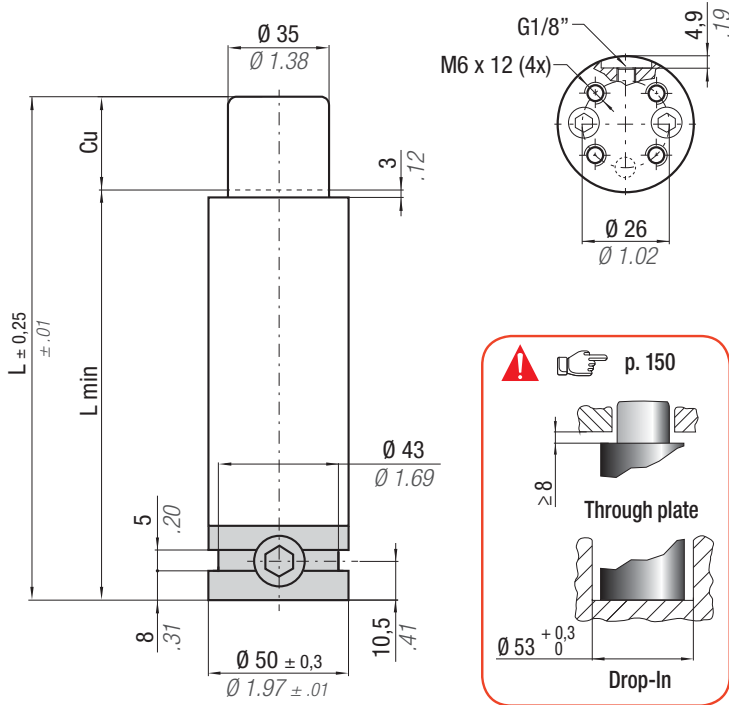

Il nuovo codice sarà fornito solo ad esaurimento del vecchio

The new code will be supplied only when the old will be out of stock

Der neue Kode wird geliefert nur wenn der alte nicht mehr im Lager ist

Le nouveau code sera fourni uniquement lorsque le vieux stock sera écoulé

El nuevo código será suministrado sólo cuando el viejo está fuera de stock

O novo código irá ser fornecido apenas quando o antigo esgotar stock

ACTIVE SAFETY



OSAS



USAS



OPAS

* $F_{1i} =$

Isothermal end force at 100% Cu



p. 16



** $F_{1p} =$

Polytrophic end force at 100% Cu

N ₂		°F 32 - 176	°C 0 - 80	ΔP ± 0,33 %/°C	P max 200 bar 2900 psi	P min 20 bar 290 psi	S 9,62 cm ² 1.491 in ²	SPM ~ 40 - 80 (at 20°C)	Max Speed 1,6 m/s	Maintenance kit 39BMMML01800C								
CODE	NEW	Cu		L		L min		F ₀		F _{1i} *		F _{1p} **		V ₀		PED 2014/68/EU		
PHASING OUT from 04/2013		mm	inch	mm	inch	mm	inch	daN	lb	daN	lb	daN	lb	cm ³	in ³	~Kg	~lb	✓
ML1800-015-B-N	ML1800-015-C-N	15	0.59	115	4.53	100	3.94	1925	4327	2818	6334	3200	7194	57,0	3.48	1,03	2.27	✓
ML1800-025-B-N	ML1800-025-C-N	25	0.98	135	5.31	110	4.33	± 5%		3182	7154	3706	8331	75,0	4.58	1,12	2.47	✓
ML1800-038-B-N	ML1800-038-C-N	38	1.50	170	6.69	132	5.20	200 bar 2900 psi		3257	7321	3811	8567	111,0	6.77	1,28	2.82	✓
ML1800-050-B-N	ML1800-050-C-N	50	1.97	195	7.68	145	5.71			3451	7758	4087	9188	134,0	8.17	1,39	3.06	✓
ML1800-063-B-N	ML1800-063-C-N	63	2.48	225	8.86	162	6.38			3546	7972	4224	9496	163,0	9.94	1,53	3.37	✓
ML1800-080-B-N	ML1800-080-C-N	80	3.15	265	10.43	185	7.28	+20 °C +68 °F		3619	8136	4329	9732	201,0	12.26	1,71	3.77	✓

ML

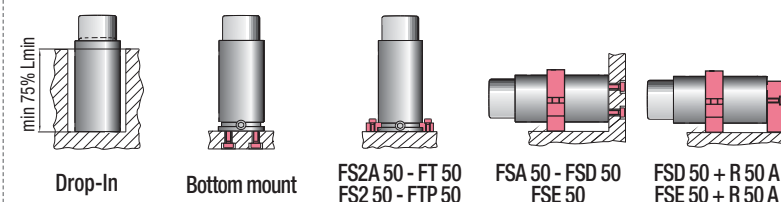

HOW TO ORDER

(10 pcs) ML1800-050-C-N

ACTIVE SAFETY



OSAS



USAS



OPAS

Il nuovo codice sarà fornito solo ad esaurimento del vecchio

The new code will be supplied only when the old will be out of stock

Der neue Kode wird geliefert nur wenn der alte nicht mehr im Lager ist

Le nouveau code sera fourni uniquement lorsque le vieux stock sera écoulé

El nuevo código será suministrado sólo cuando el viejo está fuera de stock

O novo código irá ser fornecido apenas quando o antigo esgotar stock

easu MANIFOLD p. 211

* $F_{1i} =$

Isothermal end force at 100% Cu p. 16

** $F_{1p} =$

Polytrophic end force at 100% Cu

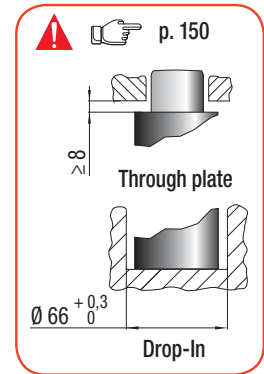
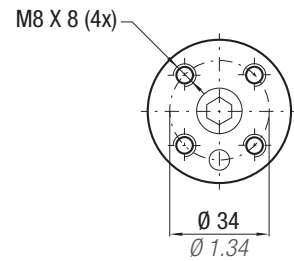
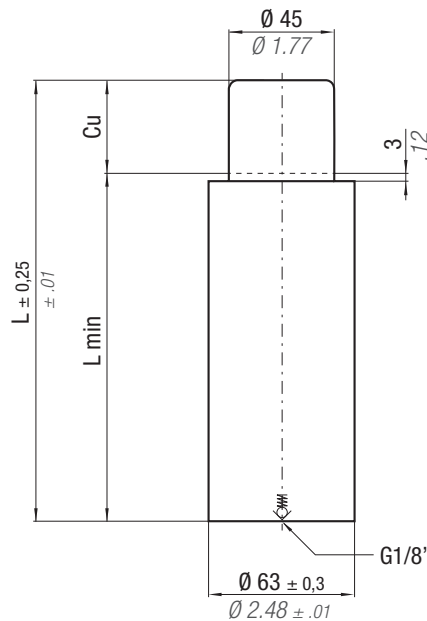

	°F 32 - 176	°C 0 - 80	ΔP ± 0,33 %/°C	P max 200 bar 2900 psi	P min 20 bar 290 psi	S 15,90 cm ² 2.464 in ²	SPM ~ 40 - 80 (at 20°C)	Max Speed 1,6 m/s	Maintenance kit 39BMMLO3000B
CODE	NEW	Cu	L	L min	F ₀	F _{1i} *	F _{1p} **	V ₀	
PHASING OUT from 04/2013		mm inch	mm inch	mm inch	Initial force daN lb	End force * daN lb	End force ** daN lb	cm ³ in ³	~Kg ~lb
ML 3000 - 015 - B	ML 3000 - 015 - C	15 0.59	100 3.94	85 3.35	3180 7149	4450 10003	5007 11256	106,0 6.47	1,25 2.76
ML 3000 - 025 - B	ML 3000 - 025 - C	25 0.98	120 4.72	95 3.74	± 5%	4996 11231	5757 12942	136,0 8.30	1,38 3.04
ML 3000 - 038 - B	ML 3000 - 038 - C	38 1.50	150 5.91	112 4.41	200 bar 2900 psi	5340 12005	6239 14026	185,0 11.29	1,57 3.46
ML 3000 - 050 - B	ML 3000 - 050 - C	50 1.97	180 7.09	130 5.12		5468 12292	6419 14430	235,0 14.34	1,78 3.92
ML 3000 - 063 - B	ML 3000 - 063 - C	63 2.48	210 8.27	147 5.79		5633 12664	6654 14959	283,0 17.26	1,98 4.37
ML 3000 - 080 - B	ML 3000 - 080 - C	80 3.15	250 9.84	170 6.69	+20 °C +68 °F	5766 12963	6844 15386	349,0 21.29	2,24 4.94

FML 3000

code: 39FML03000A

Kit speciale per trasformare cilindri autonomi
 Special kit to convert self-contained cylinders
 Spezial-Set zum Umbau eigenständiger Zylinder
 Kit spécial pour transformer les cylindres autonomes
 Kit especial para transformar cilindros autónomos
 Kit especial para transformar cilindros autónomos

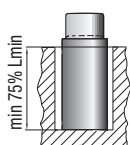
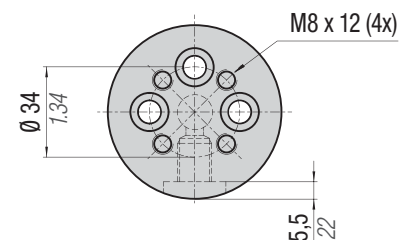
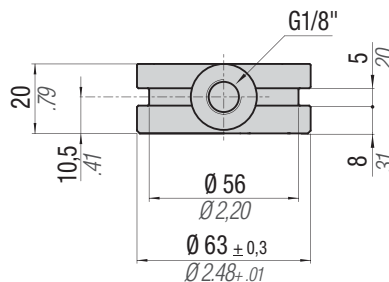

Drop-In



Bottom mount

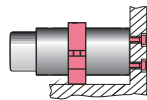

FSC 63 - FSD 63

HOW TO ORDER

(10 pcs) ML3000-050-C

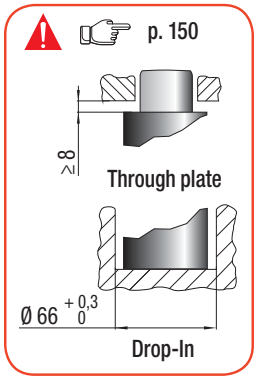
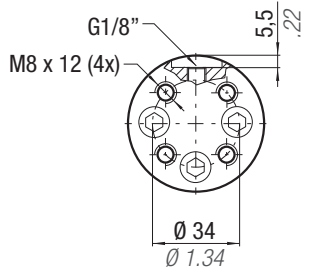
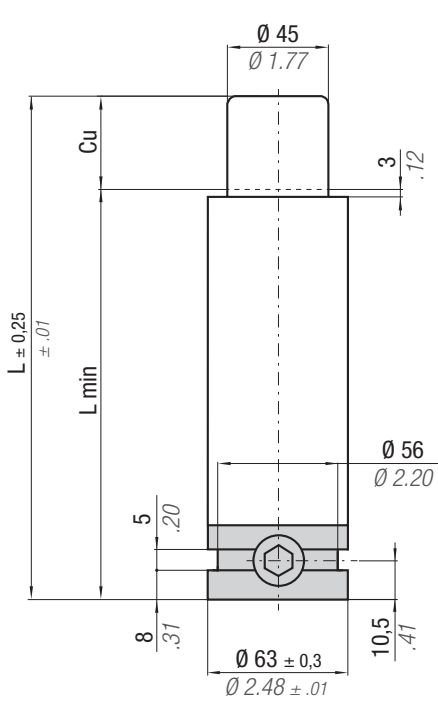

Il nuovo codice sarà fornito solo ad esaurimento del vecchio
 The new code will be supplied only when the old will be out of stock
 Der neue Kode wird geliefert nur wenn der alte nicht mehr im Lager ist
 Le nouveau code sera fourni uniquement lorsque le vieux stock sera écoulé
 El nuevo código será suministrado sólo cuando el viejo está fuera de stock
 O novo código irá ser fornecido apenas quando o antigo esgotar stock

* F_{1i} = Isothermal end force at 100% Cu
 ** F_{1p} = Polytrophic end force at 100% Cu

ACTIVE SAFETY



	$^{\circ}\text{F}$ 32 - 176	$^{\circ}\text{C}$ 0 - 80	ΔP $\pm 0,33\%/^{\circ}\text{C}$	P max 200 bar 2900 psi	P min 20 bar 290 psi	S 15,90 cm ² 2.464 in ²	SPM ~ 40 - 80 (at 20°C)	Max Speed 1,6 m/s	Maintenance kit 39BMMML03000B
--	--------------------------------------	------------------------------------	---	-------------------------------------	-----------------------------------	--	--------------------------------------	-----------------------------	---

CODE PHASING OUT from 04/2013	NEW	Cu		L		L min		F ₀ Initial force		F _{1i} * End force *		F _{1p} ** End force **		V ₀		PED 2014/68/EU		
		mm	inch	mm	inch	mm	inch	daN	lb	daN	lb	daN	lb	cm ³	in ³	~Kg	~lb	✓
ML3000-015-B-N	ML3000-015-C-N	15	0.59	120	4.72	105	4.13	3180	7149	4450	10003	5007	11256	106,0	6.47	1,67	3.68	✓
ML3000-025-B-N	ML3000-025-C-N	25	0.98	140	5.51	115	4.53	± 5%		4996	11231	5757	12942	136,0	8.30	1,80	3.97	✓
ML3000-038-B-N	ML3000-038-C-N	38	1.50	170	6.69	132	5.20	200 bar 2900 psi		5340	12005	6239	14026	185,0	11.29	2,00	4.41	✓
ML3000-050-B-N	ML3000-050-C-N	50	1.97	200	7.87	150	5.91			5468	12292	6419	14430	235,0	14.34	2,20	4.85	✓
ML3000-063-B-N	ML3000-063-C-N	63	2.48	230	9.06	167	6.57			5633	12664	6654	14959	283,0	17.26	2,40	5.29	✓
ML 3000-080-B-N	ML3000-080-C-N	80	3.15	270	10.63	190	7.48	+20 °C +68 °F		5766	12963	6844	15386	349,0	21.29	2,66	5.86	✓

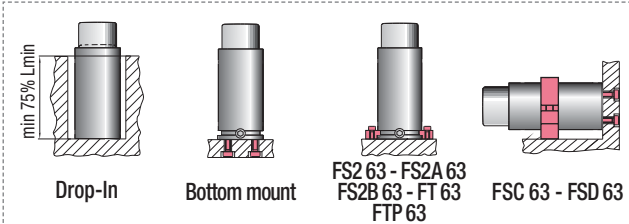

HOW TO ORDER
 (10 pcs) ML3000-050-C-N

ACTIVE SAFETY



OSAS



USAS



OPAS

Il nuovo codice sarà fornito solo ad esaurimento del vecchio

The new code will be supplied only when the old will be out of stock

Der neue Kode wird geliefert nur wenn der alte nicht mehr im Lager ist

Le nouveau code sera fourni uniquement lorsque le vieux stock sera écoulé

El nuevo código será suministrado sólo cuando el viejo está fuera de stock

O novo código irá ser fornecido apenas quando o antigo esgotar stock

easu MANIFOLD p. 211

* $F_{1i} =$

Isothermal end force at 100% Cu p. 16

** $F_{1p} =$

Polytrophic end force at 100% Cu

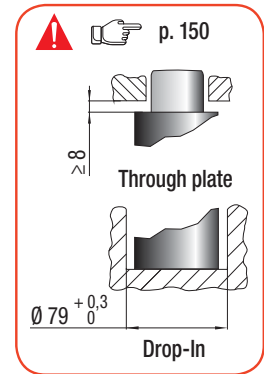
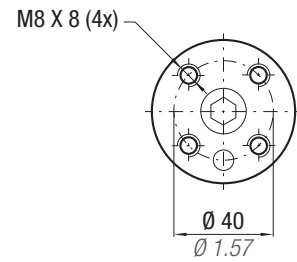
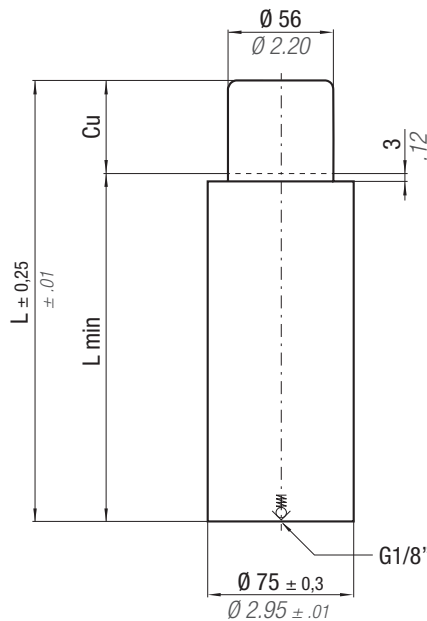

N ₂	°F 32 - 176	°C 0 - 80	ΔP ± 0,33 %/°C	P max 200 bar 2900 psi	P min 20 bar 290 psi	S 24,63 cm ² 3.817 in ²	SPM ~ 30 - 70 (at 20°C)	Max Speed 1,6 m/s	Maintenance kit 39BMML04700C
CODE	NEW	Cu	L	L min	F ₀	F _{1i} *	F _{1p} **	V ₀	PED 2014/68/EU
PHASING OUT from 04/2013		mm inch	mm inch	mm inch	Initial force daN lb	End force * daN lb	End force ** daN lb	cm ³ in ³	~Kg ~lb
ML 4700 - 015 - B	ML 4700 - 015 - C	15 0.59	100 3.94	85 3.35	4925 11071	6966 15660	7856 17661	159,0 9.70	1,72 3.79
ML 4700 - 025 - B	ML 4700 - 025 - C	25 0.98	120 4.72	95 3.74	± 5%	7858 17665	9085 20424	205,0 12.51	1,90 4.19
ML 4700 - 038 - B	ML 4700 - 038 - C	38 1.5	150 5.91	112 4.41	200 bar 2900 psi	8432 18956	9891 22236	278,0 16.96	2,17 4.78
ML 4700 - 050 - B	ML 4700 - 050 - C	50 1.97	180 7.09	130 5.12		8651 19448	10201 22933	353,0 21.53	2,44 5.38
ML 4700 - 063 - B	ML 4700 - 063 - C	63 2.48	210 8.27	147 5.79		8929 20073	10598 23825	425,0 25.93	2,72 6.00
ML 4700 - 080 - B	ML 4700 - 080 - C	80 3.15	250 9.84	170 6.69	+20 °C +68 °F	9155 20581	10922 24554	523,0 31.90	3,08 6.79

FML 4700

code: 39FML04700A

Kit speciale per trasformare cilindri autonomi
 Special kit to convert self-contained cylinders
 Spezial-Set zum Umbau eigenständiger Zylinder
 Kit spécial pour transformer les cylindres autonomes
 Kit especial para transformar cilindros autónomos
 Kit especial para transformar cilindros autónomos

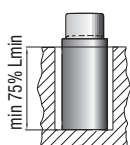
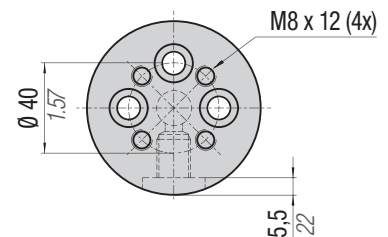
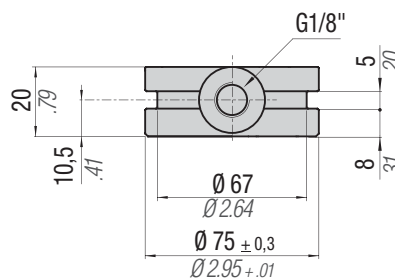

Drop-In

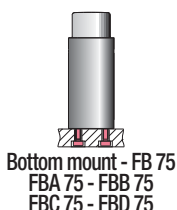

Bottom mount - FB 75
FBA 75 - FBB 75
FBC 75 - FBD 75

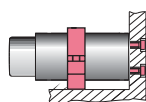

FSA 75 - FSD 75
FSE 75

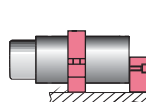

FSD 75 + R 75 A
FSE 75 + R 75 A

HOW TO ORDER

(10 pcs) ML4700-050-C

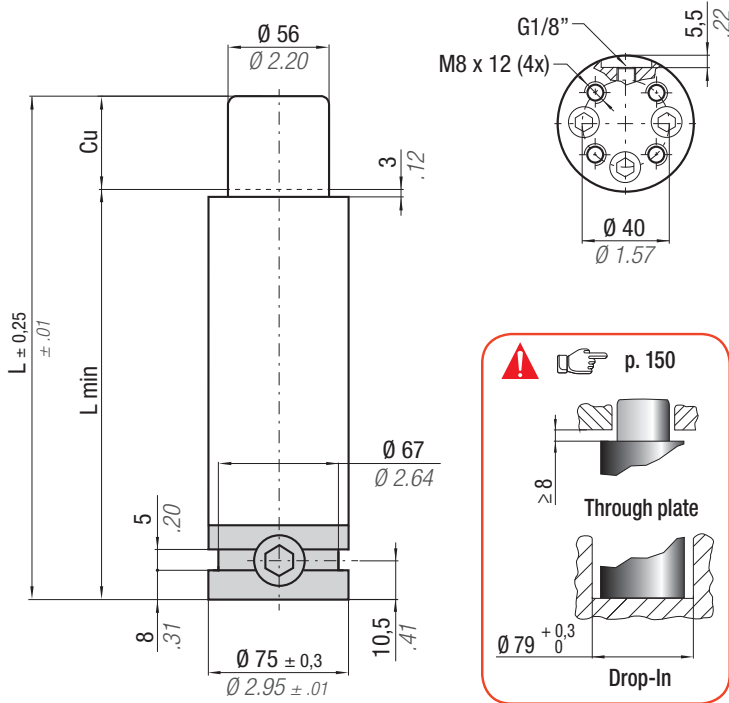

Il nuovo codice sarà fornito solo ad esaurimento del vecchio

The new code will be supplied only when the old will be out of stock

Der neue Kode wird geliefert nur wenn der alte nicht mehr im Lager ist

Le nouveau code sera fourni uniquement lorsque le vieux stock sera écoulé

El nuevo código será suministrado sólo cuando el viejo está fuera de stock

O novo código irá ser fornecido apenas quando o antigo esgotar stock

* $F_{1i} =$

Isothermal end force at 100% Cu



p. 16

** $F_{1p} =$

Polytrophic end force at 100% Cu



ACTIVE SAFETY



OSAS



USAS



OPAS

N ₂		°F 32 - 176	°C 0 - 80	ΔP ± 0,33 %/°C	P max 200 bar 2900 psi	P min 20 bar 290 psi	S 24,63 cm ² 3.817 in ²	SPM ~ 30 - 70 (at 20°C)	Max Speed 1,6 m/s	Maintenance kit 39BMMML04700C								
CODE	NEW	Cu		L		L min		F ₀ Initial force		F _{1i} * End force *		F _{1p} ** End force **		V ₀		PED 2014/68/EU		
PHASING OUT from 04/2013		mm	inch	mm	inch	mm	inch	daN	lb	daN	lb	daN	lb	cm ³	in ³	~Kg	~lb	✓
ML4700-015-B-N	ML4700-015-C-N	15	0.59	120	4.72	105	4.13	4925	11071	6966	15660	7856	17661	159,0	9.70	2,34	5.16	✓
ML4700-025-B-N	ML4700-025-C-N	25	0.98	140	5.51	115	4.53	± 5%		7858	17665	9085	20424	205,0	12.51	2,51	5.53	✓
ML4700-038-B-N	ML4700-038-C-N	38	1.50	170	6.69	132	5.20	200 bar 2900 psi		8432	18956	9891	22236	278,0	16.96	2,75	6.06	✓
ML4700-050-B-N	ML4700-050-C-N	50	1.97	200	7.87	150	5.91			8651	19448	10201	22933	353,0	21.53	3,06	6.75	✓
ML4700-063-B-N	ML4700-063-C-N	63	2.48	230	9.06	167	6.57			8929	20073	10598	23825	425,0	25.93	3,33	7.34	✓
ML4700-080-B-N	ML4700-080-C-N	80	3.15	270	10.63	190	7.48	+20 °C +68 °F		9155	20581	10922	24554	523,0	31.90	3,70	8.16	✓

ML

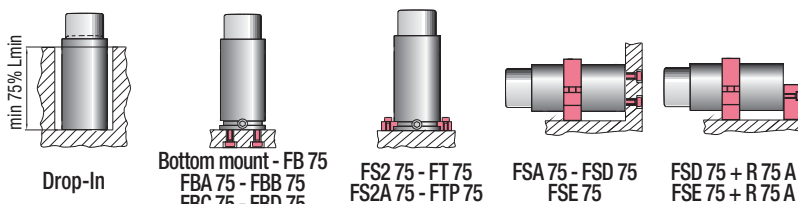

HOW TO ORDER

(10 pcs) ML4700-050-C-N

ACTIVE SAFETY



OSAS



USAS



OPAS

Il nuovo codice sarà fornito solo ad esaurimento del vecchio

The new code will be supplied only when the old will be out of stock

Der neue Kode wird geliefert nur wenn der alte nicht mehr im Lager ist

Le nouveau code sera fourni uniquement lorsque le vieux stock sera écoulé

El nuevo código será suministrado sólo cuando el viejo está fuera de stock

O novo código irá ser fornecido apenas quando o antigo esgotar stock

easu MANIFOLD p. 211

* $F_{1i} =$

Isothermal end force at 100% Cu p. 16

** $F_{1p} =$

Polytrophic end force at 100% Cu

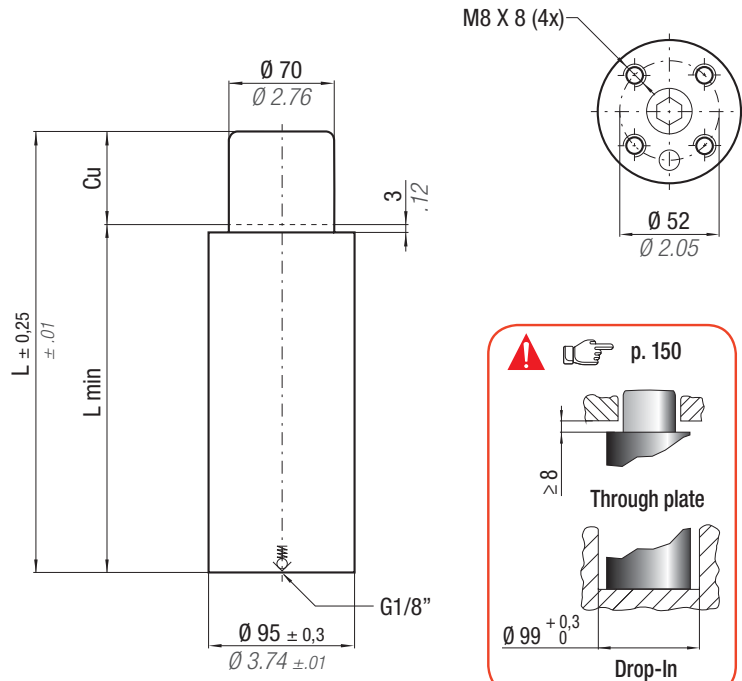

N ₂	°F 32 - 176	°C 0 - 80	ΔP ± 0,33 %/°C	P max 200 bar 2900 psi	P min 20 bar 290 psi	S 38,48 cm ² 5.964 in ²	SPM ~ 20 - 60 (at 20°C)	Max Speed 1,6 m/s	Maintenance kit 39BMML07500C
CODE	NEW	Cu	L	L min	F ₀	F _{1i} *	F _{1p} **	V ₀	
PHASING OUT from 04/2013		mm inch	mm inch	mm inch	Initial force daN lb	End force * daN lb	End force ** daN lb	cm ³ in ³	~Kg ~lb
ML 7500 - 015 - B	ML 7500 - 015 - C	15 0.59	115 4.53	100 3.94	7700 17310	10289 23131	11469 25783	291,0 17.75	3,30 7.28
ML 7500 - 025 - B	ML 7500 - 025 - C	25 0.98	135 5.31	110 4.33	± 5%	11499 25851	13116 29486	365,0 22.27	3,58 7.89
ML 7500 - 038 - B	ML 7500 - 038 - C	38 1.50	165 6.50	127 5,00	200 bar 2900 psi	12377 27825	14333 32222	481,0 29.34	4,01 8.84
ML 7500 - 050 - B	ML 7500 - 050 - C	50 1.97	190 7.48	140 5.51		13130 29517	15391 34600	575,0 35.08	4,36 9.61
ML 7500 - 063 - B	ML 7500 - 063 - C	63 2.48	220 8.66	157 6.18		13557 30477	15996 35960	691,0 42.15	4,75 10.47
ML 7500 - 080 - B	ML 7500 - 080 - C	80 3.15	260 10.24	180 7.09	+20 °C +68 °F	13910 31271	16500 37093	874,0 53.31	5,36 11.82

FML 7500

code: 39FML07500A

Kit speciale per trasformare cilindri autonomi
 Special kit to convert self-contained cylinders
 Spezial-Set zum Umbau eigenständiger Zylinder
 Kit spécial pour transformer les cylindres autonomes
 Kit especial para transformar cilindros autónomos
 Kit especial para transformar cilindros autónomos

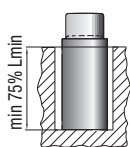
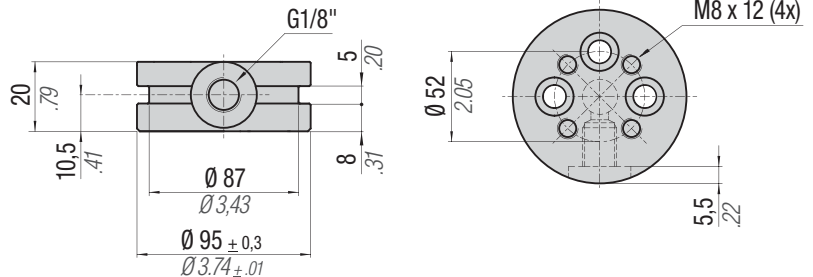

Drop-In



Bottom mount

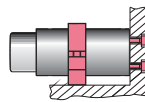

FSA 95 - FSD 95
FSE 95

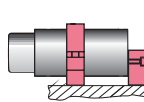

FSD 95 + R 95 A
FSE 95 + R 95 A

HOW TO ORDER

(10 pcs) ML7500-050-C

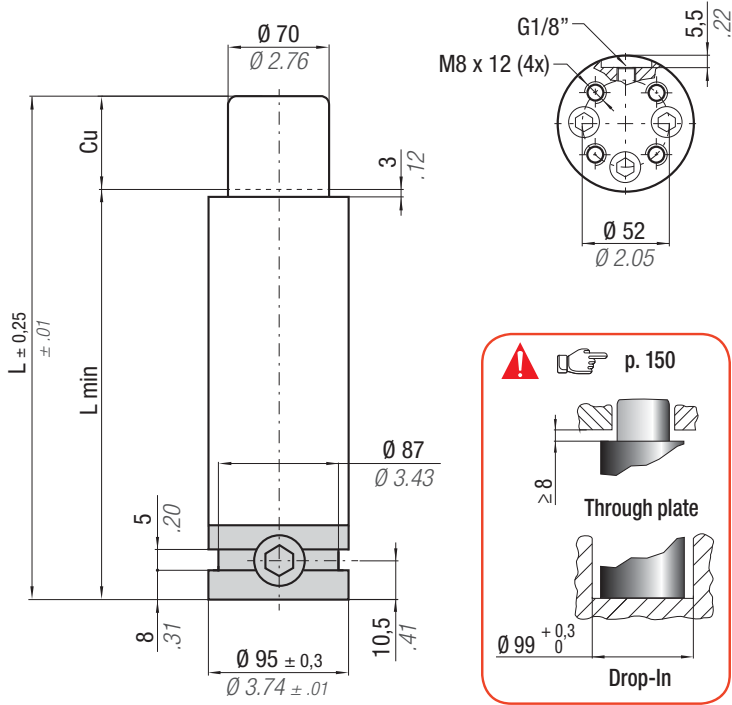

Il nuovo codice sarà fornito solo ad esaurimento del vecchio

The new code will be supplied only when the old will be out of stock

Der neue Kode wird geliefert nur wenn der alte nicht mehr im Lager ist

Le nouveau code sera fourni uniquement lorsque le vieux stock sera écoulé

El nuevo código será suministrado sólo cuando el viejo está fuera de stock

O novo código irá ser fornecido apenas quando o antigo esgotar stock

* $F_{1i} =$

Isothermal end force at 100% Cu

p. 16

** $F_{1p} =$

Polytrophic end force at 100% Cu

ACTIVE SAFETY



OSAS



USAS



OPAS

N ₂		°F 32 - 176	°C 0 - 80	ΔP ± 0,33 %/°C	P max 200 bar 2900 psi	P min 20 bar 290 psi	S 38,48 cm ² 5.964 in ²	SPM ~ 20 - 60 (at 20°C)	Max Speed 1,6 m/s	Maintenance kit 39BMML07500C								
CODE	NEW	Cu		L	L min	F ₀ Initial force		F _{1i} * End force *		F _{1p} ** End force **		V ₀		PED 2014/68/EU				
PHASING OUT from 04/2013		mm	inch	mm	inch	mm	inch	daN	lb	daN	lb	daN	lb	cm ³	in ³	~Kg	~lb	✓
ML7500-015-B-N	ML7500-015-C-N	15	0.59	135	5.31	120	4.72	7700	17310	10289	23131	11469	25783	291,0	17.75	4,32	9.52	✓
ML7500-025-B-N	ML7500-025-C-N	25	0.98	155	6.10	130	5.12	± 5%		11499	25851	13116	29486	365,0	22.27	4,60	10.14	✓
ML7500-038-B-N	ML7500-038-C-N	38	1.50	185	7.28	147	5.79	200 bar 2900 psi		12377	27825	14333	32222	481,0	29.34	5,03	11.09	✓
ML7500-050-B-N	ML7500-050-C-N	50	1.97	210	8.27	160	6.30			13130	29517	15391	34600	575,0	35.08	5,38	11.86	✓
ML7500-063-B-N	ML7500-063-C-N	63	2.48	240	9.45	177	6.97			13557	30477	15996	35960	691,0	42.15	5,81	12.81	✓
ML7500-080-B-N	ML7500-080-C-N	80	3.15	280	11.02	200	7.87	+20 °C +68 °F		13910	31271	16500	37093	874,0	53.31	6,39	14.09	✓

ML

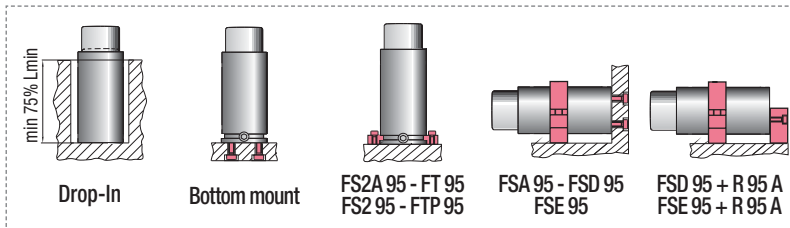

HOW TO ORDER

(10 pcs) ML7500-050-C-N

Il nuovo codice sarà fornito solo ad esaurimento del vecchio

The new code will be supplied only when the old will be out of stock

Der neue Kode wird geliefert nur wenn der alte nicht mehr im Lager ist

Le nouveau code sera fourni uniquement lorsque le vieux stock sera écoulé

El nuevo código será suministrado sólo cuando el viejo está fuera de stock

O novo código irá ser fornecido apenas quando o antigo esgotar stock

ACTIVE SAFETY



OSAS



USAS



OPAS

easu MANIFOLD p. 211

* $F_{1i} =$

Isothermal end force at 100% Cu p. 16

** $F_{1p} =$

Polytropic end force at 100% Cu

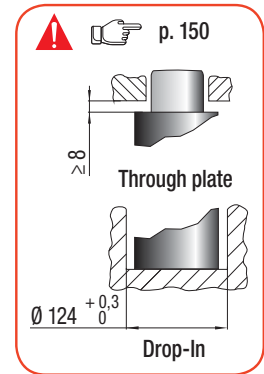
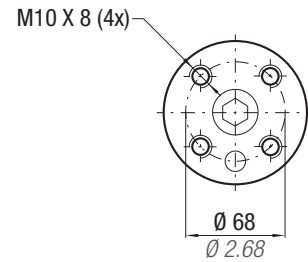
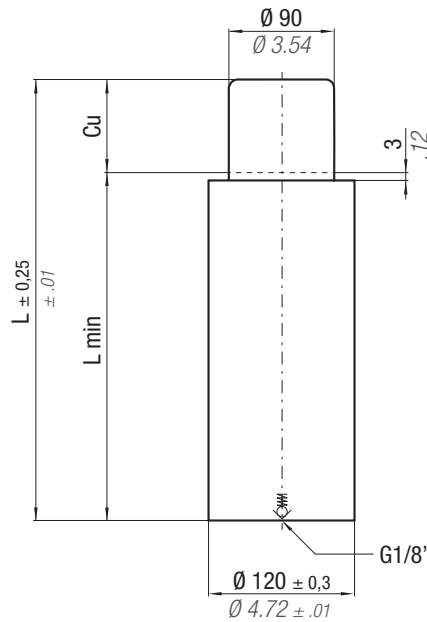

N ₂	°F 32 - 176	°C 0 - 80	ΔP ± 0,33 %/°C	P max 200 bar 2900 psi	P min 20 bar 290 psi	S 63,62 cm ² 9.861 in ²	SPM ~ 20 - 50 (at 20°C)	Max Speed 1,6 m/s	Maintenance kit 39BMML12000C
CODE	NEW	Cu	L	L min	F ₀	F _{1i} *	F _{1p} **	V ₀	
PHASING OUT from 04/2013		mm inch	mm inch	mm inch	Initial force daN lb	End force * daN lb	End force ** daN lb	cm ³ in ³	~Kg ~lb
ML 12000 - 015 - B: ML 12000 - 015 - C		15 0.59	115 4.53	100 3.94	12720 28595	17877 40189	20134 45263	417,0 25.44	5,82 12.83
ML 12000 - 025 - B: ML 12000 - 025 - C		25 0.98	135 5.31	110 4.33	± 5%	20211 45436	23346 52484	534,0 32.57	6,29 13.87
ML 12000 - 038 - B: ML 12000 - 038 - C		38 1.50	165 6.50	127 5	200 bar 2900 psi	21787 48979	25558 57457	718,0 43.80	7,01 15.45
ML 12000 - 050 - B: ML 12000 - 050 - C		50 1.97	195 7.68	145 5.71		22429 50422	26470 59507	906,0 55.27	7,74 17.06
ML 12000 - 063 - B: ML 12000 - 063 - C		63 2.48	225 8.86	162 6.38		23211 52180	27586 62016	1089,0 66.43	8,46 18.65
ML 12000 - 080 - B: ML 12000 - 080 - C		80 3.15	265 10.43	185 7.28	+20 °C +68 °F	23860 53639	28520 64116	1335,0 81.44	9,43 20.79

FML 12000

code: 39FML12000A

Kit speciale per trasformare cilindri autonomi
 Special kit to convert self-contained cylinders
 Spezial-Set zum Umbau eigenständiger Zylinder
 Kit spécial pour transformer les cylindres autonomes
 Kit especial para transformar cilindros autónomos
 Kit especial para transformar cilindros autónomos

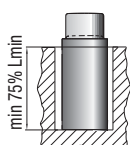
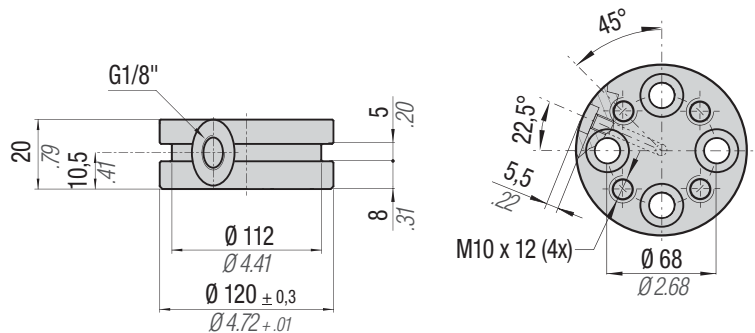

Drop-In



Bottom mount

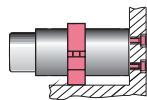

FSA 120 - FSD 120

HOW TO ORDER

(10 pcs) ML12000-050-C

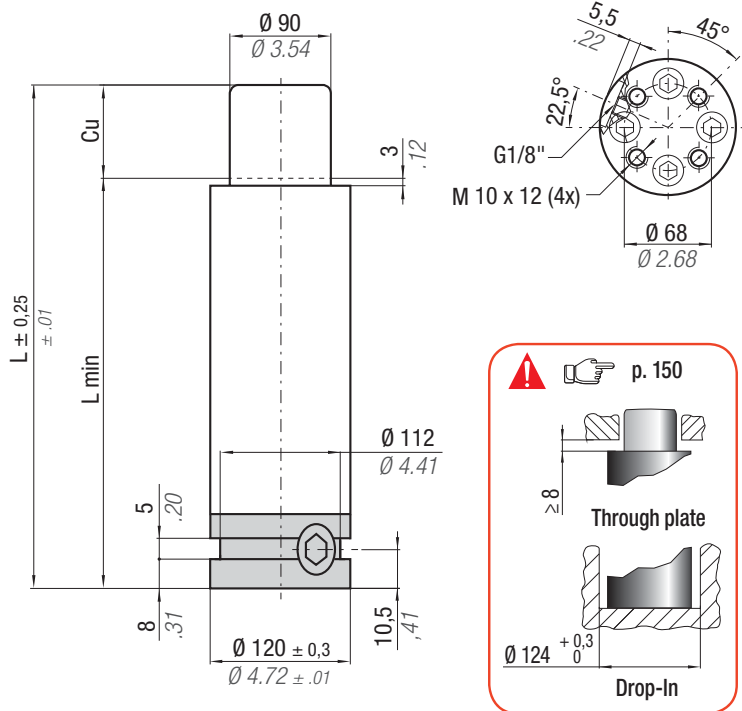

Il nuovo codice sarà fornito solo ad esaurimento del vecchio

The new code will be supplied only when the old will be out of stock

Der neue Kode wird geliefert nur wenn der alte nicht mehr im Lager ist

Le nouveau code sera fourni uniquement lorsque le vieux stock sera écoulé

El nuevo código será suministrado sólo cuando el viejo está fuera de stock

O novo código irá ser fornecido apenas quando o antigo esgotar stock

ACTIVE SAFETY

OSAS

USAS

OPAS

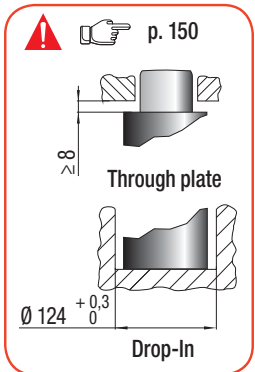

* F_{1i} = Isothermal end force at 100% Cu

** F_{1p} = Polytrophic end force at 100% Cu

See p. 16 for details.

N ₂		°F 32 - 176	°C 0 - 80	ΔP ± 0,33%/°C	P max 200 bar 2900 psi	P min 20 bar 290 psi	S 63,62 cm ² 9.861 in ²	SPM ~ 20 - 50 (at 20°C)	Max Speed 1,6 m/s	Maintenance kit 39BMML12000C
CODE	NEW	Cu	L	L min	F0	F _{1i} *	F _{1p} **	V0	PED 2014/68/EU	
PHASING OUT from 04/2013		mm inch	mm inch	mm inch	daN lb	daN lb	daN lb	cm ³ in ³	~Kg ~lb	✓
ML12000-015-B-N	ML12000-015-C-N	15 0.59	135 5.31	120 4.72	12720 28595	17877 40189	20134 45263	417,0 25.44	7,45 16.42	✓
ML12000-025-B-N	ML12000-025-C-N	25 0.98	155 6.10	130 5.12	± 5%	20211 45436	23346 52484	534,0 32.57	7,92 17.46	✓
ML12000-038-B-N	ML12000-038-C-N	38 1.50	185 7.28	147 5.79	200 bar 2900 psi	21787 48979	25558 57457	718,0 43.80	8,64 19.05	✓
ML12000-050-B-N	ML12000-050-C-N	50 1.97	215 8.46	165 6.50		22429 50422	26470 59507	906,0 55.27	9,37 20.66	✓
ML12000-063-B-N	ML12000-063-C-N	63 2.48	245 9.65	182 7.17		23211 52180	27586 62016	1089,0 66.43	10,09 22.24	✓
ML12000-080-B-N	ML12000-080-C-N	80 3.15	285 11.22	205 8.07	+20 °C +68 °F	23860 53639	28520 64116	1335,0 81.44	11,06 24.38	✓

ML

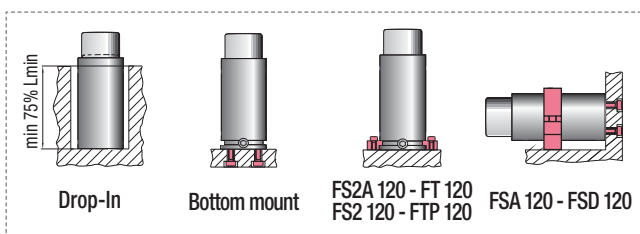

HOW TO ORDER

(10 pcs) ML12000-050-C-N

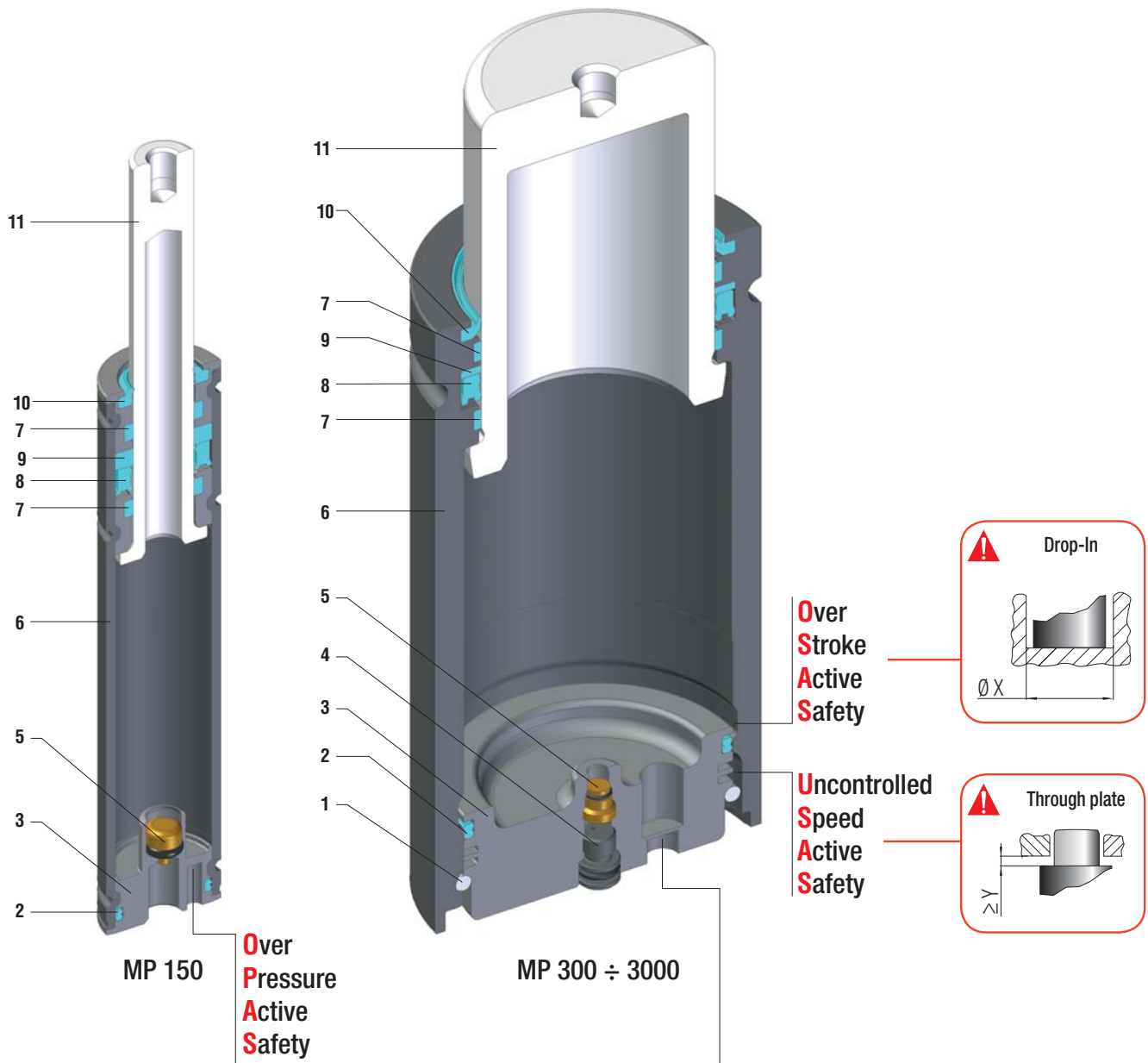





Massima forza, tenuta stelo - Maximum force, rod sealed - Maximale Kraft, Kolbenstange dichtung
 Forces maximale, joint de tige - Máxima fuerza, estanqueidad vástago - Força máxima, estanquidade na haste

SEALING	ROD SEAL
DESIGN	BOTTOM BASE - BODY DESIGN

1	Retaining ring	5	Valve	9	Back-up ring
2	Dual ring seal	6	Body	10	Rod wiper
3	Bottom base	7	Guide ring	11	Rod (nitrited superfinished)
4	Plug	8	Rod seal		

RANGE CHART

Model	Body Ø		Stroke Cu		Initial force F0					
	mm	inch	mm	inch	daN	lb	OSAS	USAS	OPAS	SKUDO
MP 150	19	0.75	15 - 80	0.59 - 3.15	150	337	-	-	✓	-
MP 300	25	0.98	15 - 80	0.59 - 3.15	300	674	✓	✓	✓	-
MP 500	32	1.26	10 - 80	0.59 - 3.15	500	1124	✓	✓	✓	-
MP 1000	38	1.50	10 - 80	0.39 - 3.15	1000	2248	✓	✓	✓	-
MP 2000	50	1.97	10 - 80	0.39 - 3.15	2000	4496	✓	✓	✓	-
MP 3000	63	2.48	10 - 80	0.39 - 3.15	3000	6744	✓	✓	✓	-



HOW TO ORDER

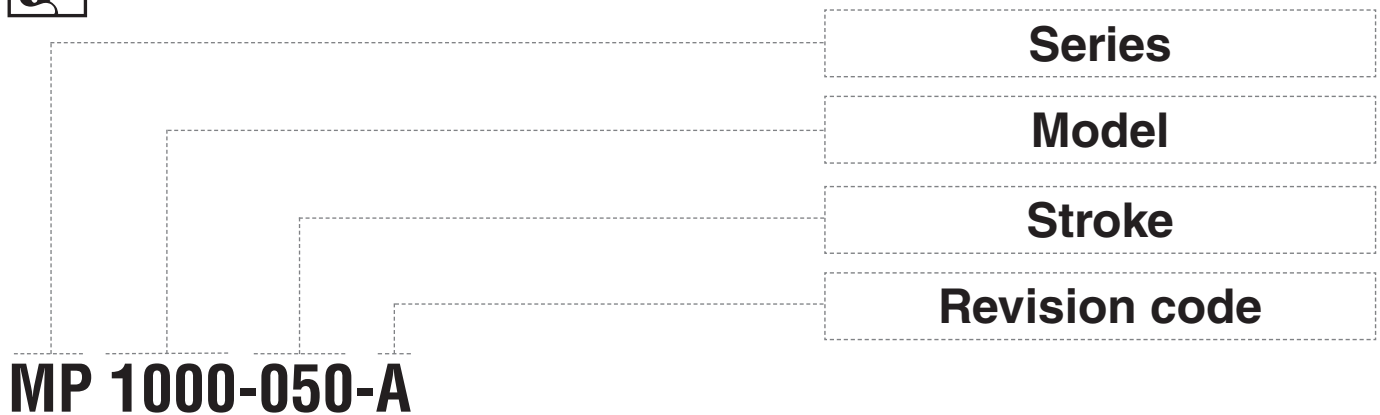

MP 1000-050-A

- IT** Codice cilindro autonomo
- EN** Self-contained cylinder code
- DE** Kode des eingeständigen Gdf.
- FR** Code du cylindre autonome
- ES** Código del cilindro autónomo
- PT** Código do cilindro autónomo

ACTIVE SAFETY



* $F_{1i} =$ Isothermal end force at 100% Cu p. 16 ** $F_{1p} =$ Polytrophic end force at 100% Cu

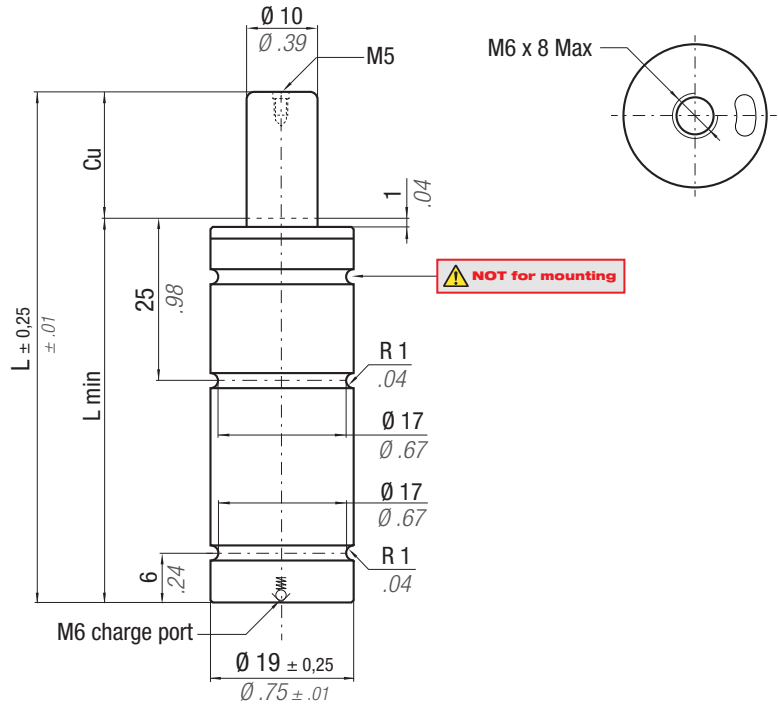

CODE	N ₂	°F 32 - 176	°C 0 - 80	ΔP ± 0,33 %/°C	P max 191 bar 2770 psi	P min 20 bar 290 psi	S 0,79 cm ² 0,122 in ²	SPM ~ 40 - 80 (at 20°C)	Max Speed 1,8 m/s	Maintenance kit Disposable	Cu		L		L min		F ₀ Initial force		F _{1i} * End force *		F _{1p} ** End force **		V ₀		PED 2014/68/EU		
											mm	inch	mm	inch	mm	inch	daN	lb	daN	lb	daN	lb	cm ³	in ³	~Kg	~lb	✓
MP 150 - 015 - A											15	0.59	85	3.35	70	2.76	150 ± 5% 191 bar 2770 psi + 20 °C +68 °F	195	438	214	481	6,4	0.39	0,09	0.20	✓	✓
MP 150 - 020 - A										20	0.79	95	3.74	75	2.95	203		456	225	506	7,5	0.46	0,10	0.22	✓	✓	
MP 150 - 025 - A										25	0.98	105	4.13	80	3.15	209		470	234	526	8,6	0.52	0,11	0.24	✓	✓	
MP 150 - 032 - A										32	1.26	120	4.72	88	3.46	214		481	241	542	10,4	0.63	0,11	0.24	✓	✓	
MP 150 - 038 - A										38	1.50	135	5.31	97	3.82	214		481	241	542	12,4	0.76	0,12	0.26	✓	✓	
MP 150 - 045 - A										45	1.77	150	5.91	105	4.13	217		488	245	551	14,1	0.86	0,13	0.29	✓	✓	
MP 150 - 050 - A										50	1.97	160	6.3	110	4.33	220		495	249	560	15,3	0.93	0,14	0.31	✓	✓	
MP 150 - 056 - A										56	2.20	175	6.89	119	4.69	219		492	248	558	17,2	1.05	0,14	0.31	✓	✓	
MP 150 - 063 - A										63	2.48	190	7.48	127	5.00	221		497	251	564	19,0	1.16	0,15	0.33	✓	✓	
MP 150 - 080 - A										80	3.15	220	8.66	140	5.51	231		519	264	593	22,0	1.34	0,17	0.37	✓	✓	

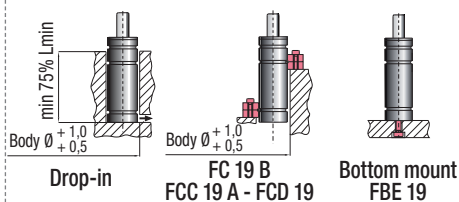

HOW TO ORDER

(10 pcs) MP 150-050-A

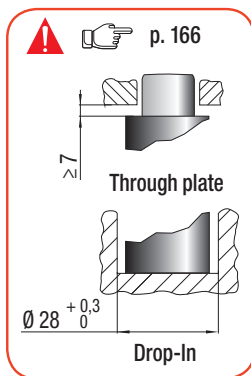
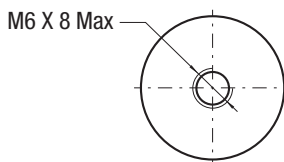
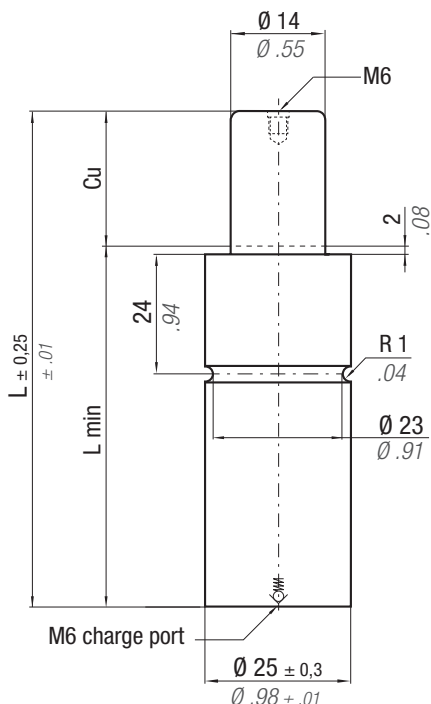

* F_{1i} =
Isothermal
end force
at 100% Cu



p. 16



** F_{1p} =
Polytropic
end force
at 100% Cu

ACTIVE SAFETY



OSAS



USAS



OPAS

N₂	°F 32 - 176	°C 0 - 80	ΔP ± 0,33 %/°C	P max 195 bar 2828 psi	P min 20 bar 290 psi	S 1,54 cm ² 0,239 in ²	SPM ~ 40 - 80 (at 20°C)	Max Speed 1,6 m/s	Maintenance kit Disposable
----------------------	-----------------------------	---------------------------	--------------------------	-------------------------------------	-----------------------------------	---	--------------------------------------	-----------------------------	--------------------------------------

CODE	Cu		L		L min		F ₀ Initial force		F _{1i} * End force *		F _{1p} ** End force **		V ₀		Maintenance kit		PED 2014/68/EU
	mm	inch	mm	inch	mm	inch	daN	lb	daN	lb	daN	lb	cm ³	in ³	~Kg	~lb	
MP 300 - 015 - A	15	0.59	85	3.35	70	2.76	300 ± 5% 195 bar 2828 psi + 20 °C +68 °F	674	462	1039	526	1182	8,2	0.50	0,18	0.40	✓
MP 300 - 020 - A	20	0.79	95	3.74	75	2.95			489	1099	563	1266	9,8	0.60	0,20	0.44	✓
MP 300 - 025 - A	25	0.98	105	4.13	80	3.15			510	1147	592	1331	11,5	0.70	0,21	0.46	✓
MP 300 - 032 - A	32	1.26	120	4.72	88	3.46			524	1178	613	1378	14,1	0.86	0,23	0.51	✓
MP 300 - 038 - A	38	1.50	135	5.31	97	3.82			520	1169	606	1362	17,0	1.04	0,25	0.55	✓
MP 300 - 045 - A	45	1.77	150	5.91	105	4.13			529	1189	620	1394	19,6	1.20	0,27	0.60	✓
MP 300 - 050 - A	50	1.97	160	6.30	110	4.33			538	1209	633	1423	21,3	1.30	0,28	0.62	✓
MP 300 - 056 - A	56	2.20	175	6.89	119	4.69			533	1198	626	1407	24,1	1.47	0,30	0.66	✓
MP 300 - 063 - A	63	2.48	190	7.48	127	5.00			539	1212	634	1425	26,7	1.63	0,32	0.71	✓
MP 300 - 080 - A	80	3.15	225	8.86	145	5.71			555	1248	656	1475	32,7	1.99	0,36	0.79	✓

MP

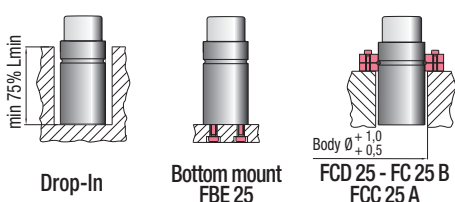

HOW TO ORDER

(10 pcs) MP 300-050-A

ACTIVE SAFETY



OSAS



USAS



OPAS

* $F_{1i} =$

Isothermal end force at 100% Cu



p. 16



** $F_{1p} =$

Polytropic end force at 100% Cu

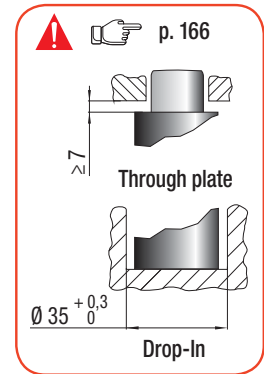
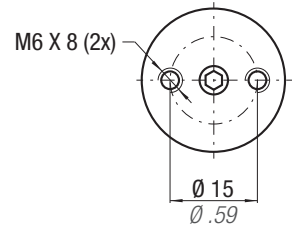
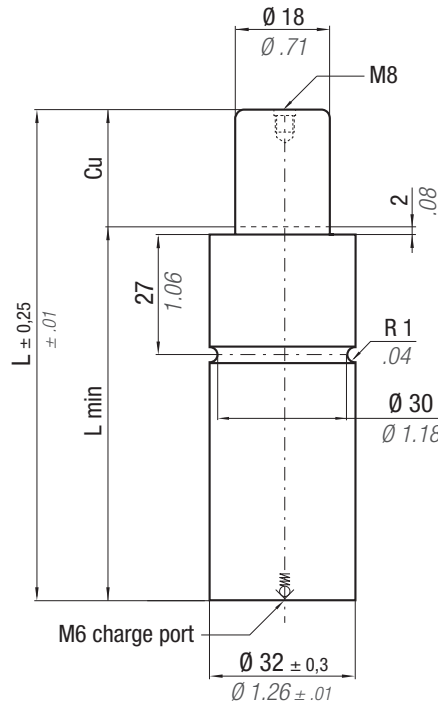

CODE	N ₂	°F 32 - 176	°C 0 - 80	ΔP ± 0,33 %/°C	P max 197 bar 2857 psi	P min 20 bar 290 psi	S 2,54 cm ² 0,394 in ²	SPM ~ 40 - 80 (at 20°C)	Max Speed 1,6 m/s	Maintenance kit Disposable	Cu		L		L min		F ₀		F _{1i} *		F _{1p} **		V ₀		PED			
											mm	inch	mm	inch	mm	inch	daN	lb	daN	lb	daN	lb	cm ³	in ³	~Kg	~lb	2014/68/EU	
MP 500 - 010 - A												10	0.39	75	2.95	65	2.56	500 ± 5%	1124	659	1481	723	1625	13,4	0.82	0,29	0,64	✓
MP 500 - 015 - A											15	0.59	85	3.35	70	2.76	709			1594	790	1776	16,4	1.00	0,31	0,68	✓	
MP 500 - 020 - A											20	0.79	95	3.74	75	2.95	747			1679	842	1893	19,3	1.18	0,33	0,73	✓	
MP 500 - 025 - A											25	0.98	105	4.13	80	3.15	778			1749	884	1987	22,2	1.35	0,34	0,75	✓	
MP 500 - 032 - A											32	1.26	120	4.72	88	3.46	803			1805	919	2066	26,8	1.63	0,37	0,82	✓	
MP 500 - 038 - A											38	1.50	135	5.31	97	3.82	804			1807	920	2068	31,8	1.94	0,40	0,88	✓	
MP 500 - 045 - A											45	1.77	150	5.91	105	4.13	820			1843	943	2120	36,4	2.22	0,43	0,95	✓	
MP 500 - 050 - A											50	1.97	160	6.30	110	4.33	834			1875	963	2165	39,3	2.40	0,45	0,99	✓	
MP 500 - 056 - A											56	2.20	175	6.89	119	4.69	831			1868	958	2154	44,3	2.70	0,48	1.06	✓	
MP 500 - 063 - A											63	2.48	195	7.68	132	5.20	816			1834	937	2106	51,4	3.14	0,52	1.15	✓	
MP 500 - 080 - A											80	3.15	230	9.06	150	5.91	844	1897	976	2194	61,8	3.77	0,59	1.30	✓			

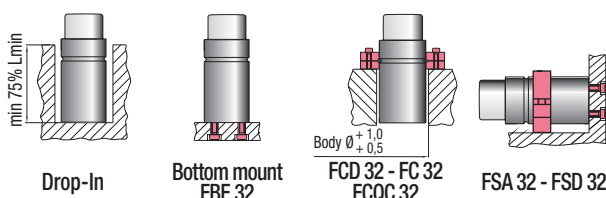

HOW TO ORDER

(10 pcs) MP 500-050-A

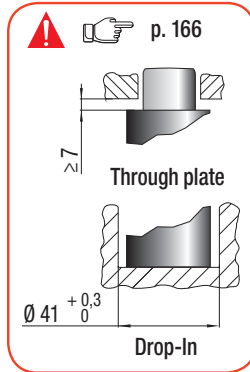
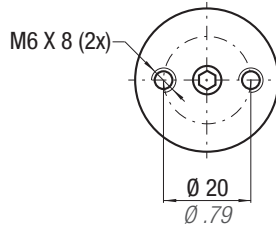
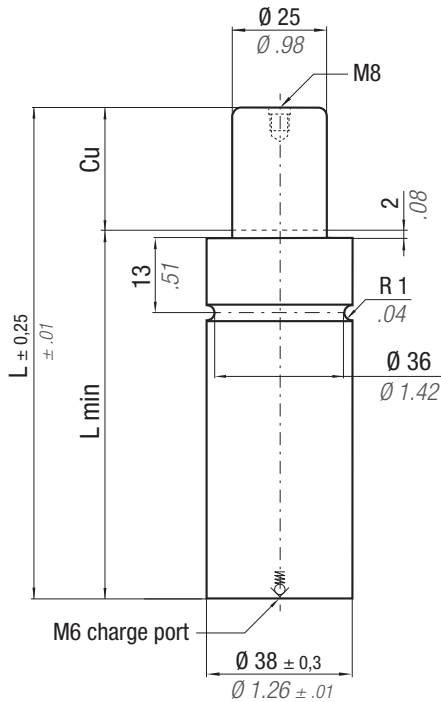

* $F_{1i} =$

Isothermal end force at 100% Cu



p. 16



** $F_{1p} =$

Polytropic end force at 100% Cu

ACTIVE SAFETY



OSAS



USAS



OPAS

	$^{\circ}\text{F}$ 32 - 176	$^{\circ}\text{C}$ 0 - 80	ΔP $\pm 0,33\% / ^{\circ}\text{C}$	P max 205 bar 2973 psi	P min 20 bar 290 psi	S 4,91 cm ² 0.761 in ²	SPM ~ 40 - 80 (at 20°C)	Max Speed 1,6 m/s	Maintenance kit 39BMMP01000A
--	--------------------------------------	------------------------------------	---	-------------------------------------	-----------------------------------	---	--------------------------------------	-----------------------------	--

CODE	Cu		L		L min		F ₀ Initial force		F _{1i} * End force *		F _{1p} ** End force **		V ₀		~Kg ~lb		PED 2014/68/EU
	mm	inch	mm	inch	mm	inch	daN	lb	daN	lb	daN	lb	cm ³	in ³			
MP 1000 - 010 - A	10	0.39	75	2.95	65	2.56	1000 ± 5%	2248	1417	3186	1588	3570	21,5	1.31	0,37	0.82	✓
MP 1000 - 015 - A	15	0.59	85	3.35	70	2.76			1545	3473	1762	3961	26,6	1.62	0,39	0.86	✓
MP 1000 - 020 - A	20	0.79	95	3.74	75	2.95			1645	3698	1898	4267	31,6	1.93	0,41	0.90	✓
MP 1000 - 025 - A	25	0.98	105	4.13	80	3.15			1724	3876	2009	4516	36,7	2.24	0,44	0.97	✓
MP 1000 - 032 - A	32	1.26	120	4.72	88	3.46			1789	4022	2100	4721	44,5	2.71	0,48	1.06	✓
MP 1000 - 038 - A	38	1.50	135	5.31	97	3.82			1790	4024	2101	4723	52,8	3.22	0,51	1.12	✓
MP 1000 - 045 - A	45	1.77	150	5.91	105	4.13			1832	4118	2159	4854	60,6	3.70	0,55	1.21	✓
MP 1000 - 050 - A	50	1.97	160	6.3	110	4.33			1868	4199	2210	4968	65,7	4.01	0,58	1.28	✓
MP 1000 - 056 - A	56	2.20	175	6.89	119	4.69			1859	4179	2198	4941	74,0	4.51	0,62	1.37	✓
MP 1000 - 063 - A	63	2.48	205	8.07	142	5.59			1716	3858	1997	4489	93,1	5.68	0,70	1.54	✓
MP 1000 - 080 - A	80	3.15	240	9.45	160	6.30	1792	4029	2103	4728	111,1	6.78	0,79	1.74	✓		

MP

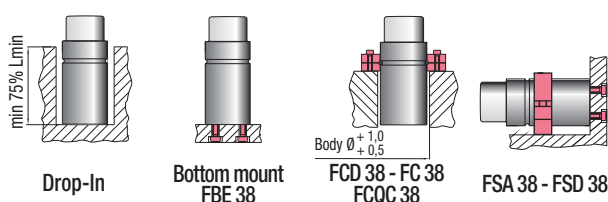

HOW TO ORDER

(10 pcs) MP 1000-050-A

ACTIVE SAFETY



OSAS



USAS



OPAS

* $F_{1i} =$

Isothermal end force at 100% Cu



p. 16



** $F_{1p} =$

Polytropic end force at 100% Cu

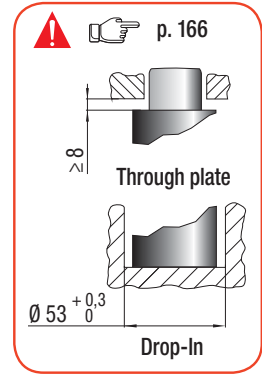
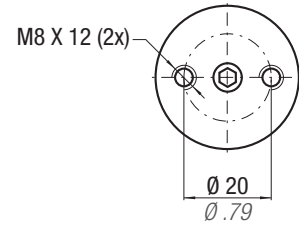
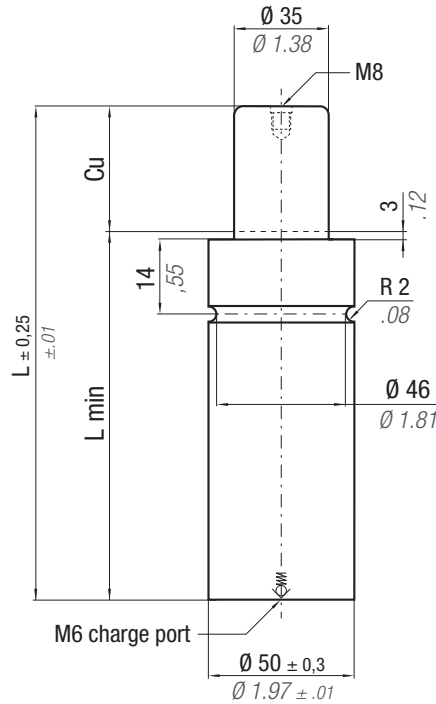

CODE	N ₂	°F 32 - 176	°C 0 - 80	ΔP ± 0,33 %/°C	P max 209 bar 3031 psi	P min 20 bar 290 psi	S 9,62 cm ² 1.491 in ²	SPM ~ 40 - 80 (at 20°C)	Max Speed 1,6 m/s	Maintenance kit 39BMMP02000A	Vo		PED		
											cm ³	in ³	~Kg	~lb	2014/68/EU
MP 2000 - 010 - A											52,0	3,17	0,76	1,68	✓
MP 2000 - 015 - A											80,0	4,88	0,89	1,96	✓
MP 2000 - 020 - A											89,1	5,44	0,93	2,05	✓
MP 2000 - 025 - A											98,3	6,00	0,98	2,16	✓
MP 2000 - 032 - A											112,3	6,85	1,04	2,29	✓
MP 2000 - 038 - A											127,1	7,75	1,11	2,45	✓
MP 2000 - 045 - A											141,1	8,61	1,18	2,60	✓
MP 2000 - 050 - A											150,3	9,17	1,22	2,69	✓
MP 2000 - 056 - A											165,0	10,07	1,29	2,84	✓
MP 2000 - 063 - A											179,1	10,93	1,36	3,00	✓
MP 2000 - 080 - A											211,4	12,9	1,51	3,33	✓

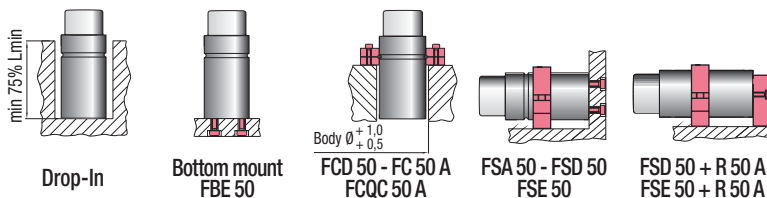

HOW TO ORDER

(10 pcs) MP 2000-050-A

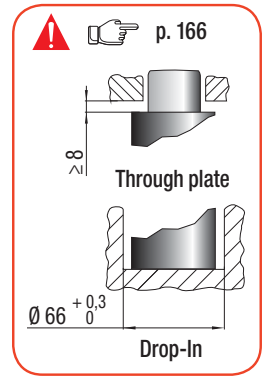
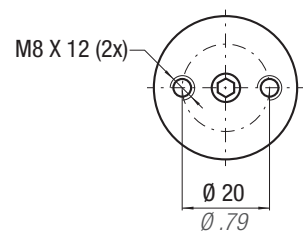
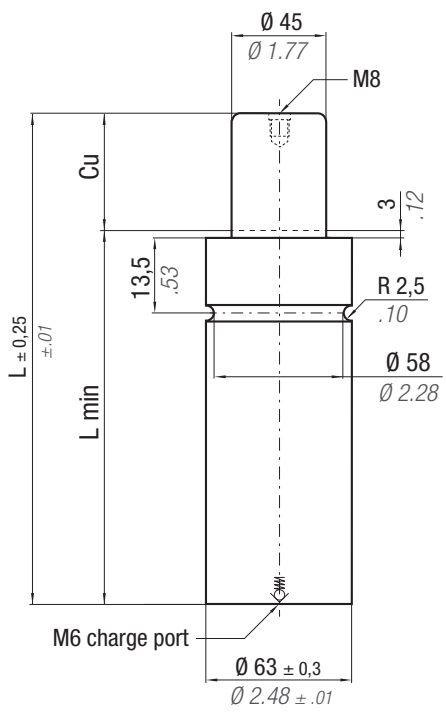

* F_{1i} = Isothermal end force at 100% Cu p. 16

** F_{1p} = Polytrophic end force at 100% Cu

ACTIVE SAFETY



CODE	Cu		L		L min		F ₀		F _{1i} *		F _{1p} **		V ₀		Maintenance kit		
	mm	inch	mm	inch	mm	inch	daN	lb	daN	lb	daN	lb	cm ³	in ³	~Kg	~lb	
MP 3000 - 010 - A	10	0.39	95	3.74	85	3.35	3000 ± 5% 189 bar 2741 psi + 20 °C +68 °F	6744	3862	8682	4243	9539	89,7	5.47	1,25	2.76	✓
MP 3000 - 015 - A	15	0.59	115	4.53	100	3.94			3932	8839	4339	9754	126,4	7.71	1,40	3.09	✓
MP 3000 - 020 - A	20	0.79	125	4.92	105	4.13			4165	9363	4657	10469	141,8	8.65	1,46	3.22	✓
MP 3000 - 025 - A	25	0.98	135	5.31	110	4.33			4370	9824	4941	11108	157,2	9.59	1,52	3.35	✓
MP 3000 - 032 - A	32	1.26	150	5.91	118	4.65			4593	10325	5253	11809	180,9	11.03	1,62	3.57	✓
MP 3000 - 038 - A	38	1.50	165	6.50	127	5.00			4696	10557	5399	12137	205,8	12.55	1,72	3.79	✓
MP 3000 - 045 - A	45	1.77	180	7.09	135	5.31			4856	10917	5626	12648	229,6	14.01	1,82	4.01	✓
MP 3000 - 050 - A	50	1.97	190	7.48	140	5.51			4975	11184	5795	13028	245,0	14.95	1,89	4.17	✓
MP 3000 - 063 - A	63	2.48	220	8.66	157	6.18			5137	11548	6029	13554	293,6	17.91	2,08	4.59	✓
MP 3000 - 080 - A	80	3.15	255	10.04	175	6.89			5389	12115	6395	14377	348,2	21.24	2,31	5.09	✓

MP

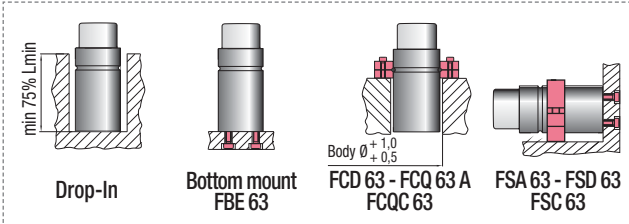

HOW TO ORDER

(10 pcs) MP 3000-050-A

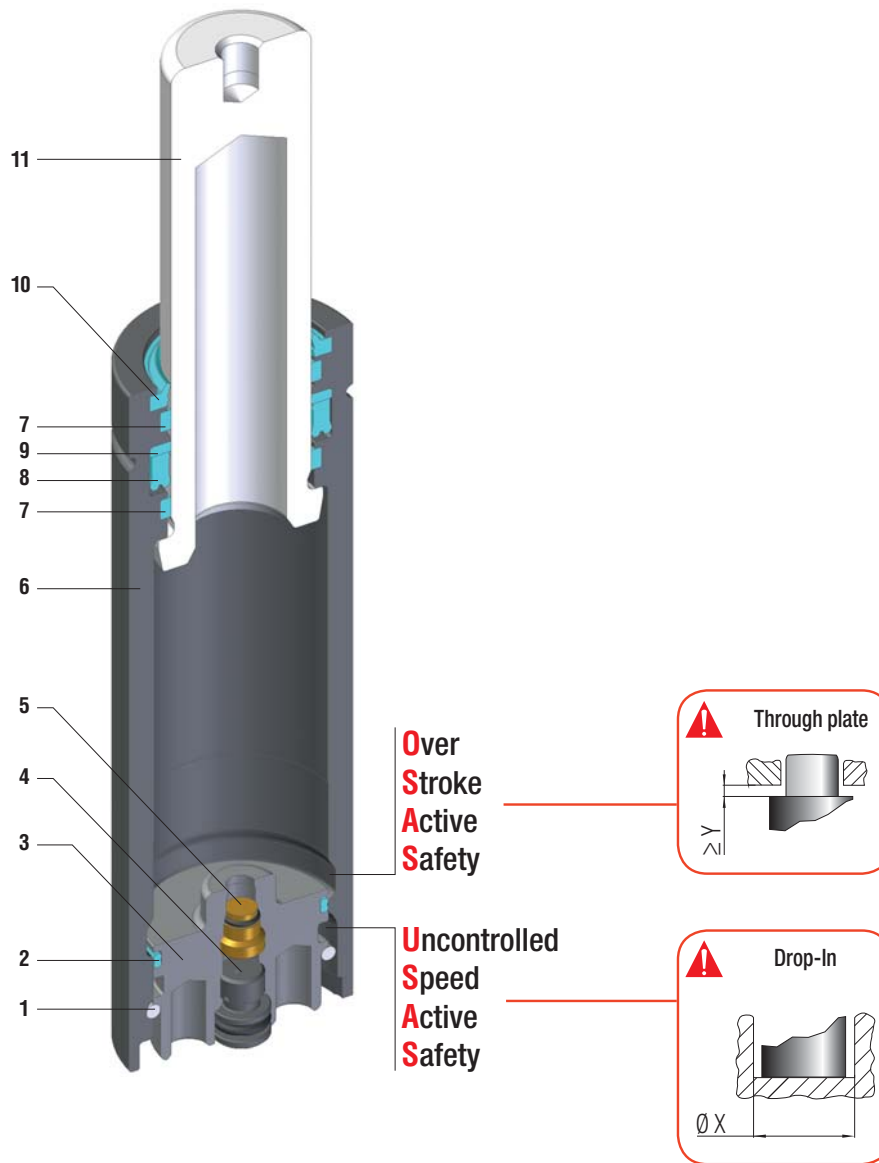





∅ 32 | Massima forza, tenuta stelo - Maximum force, rod sealed - Maximale Kraft, Kolbenstange dichtung
 Forces maximale, joint de tige - Máxima fuerza, estanqueidad vástago - Força máxima, estanquidade na haste

SEALING	ROD SEAL
DESIGN	BOTTOM BASE - BODY DESIGN

1	Retaining ring	5	Valve	9	Back-up ring
2	Dual ring seal	6	Body	10	Rod wiper
3	Bottom base	7	Guide ring	11	Rod (nitrited superfinished)
4	Plug	8	Rod seal		

RANGE CHART

Model	Body Ø		Stroke Cu		Initial force F0		 OSAS	 USAS	 OPAS	 SKUDO
	mm	inch	mm	inch	daN	lb				
MQ 700	32	1.26	10 - 80	0.39 - 3.15	660	1484	✓	✓	-	-



HOW TO ORDER

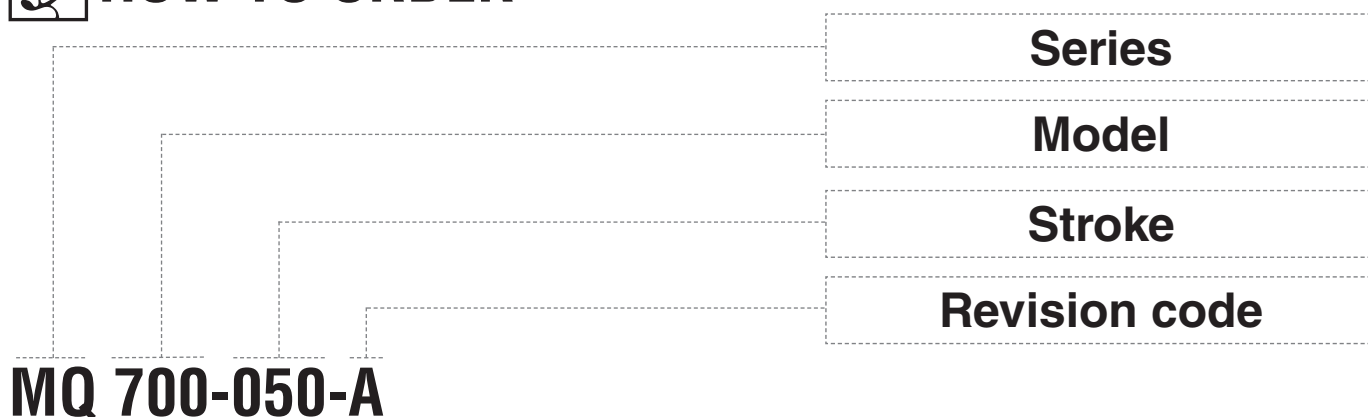

MQ 700-050-A

- IT** Codice cilindro autonomo
- EN** Self-contained cylinder code
- DE** Kode des eingeständigen Gdf.
- FR** Code du cylindre autonome
- ES** Código del cilindro autónomo
- PT** Código do cilindro autónomo

ACTIVE SAFETY



OSAS



USAS

* $F_{1i} =$
Isothermal
end force at 100% Cu



p. 16



** $F_{1p} =$
Polytrophic
end force at 100% Cu

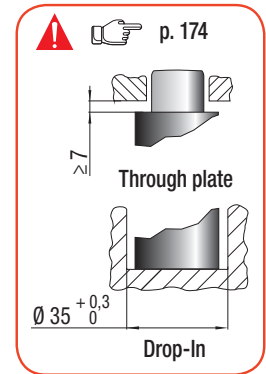
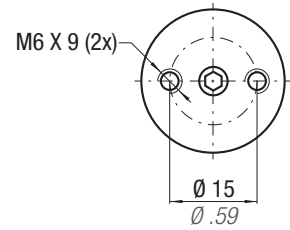
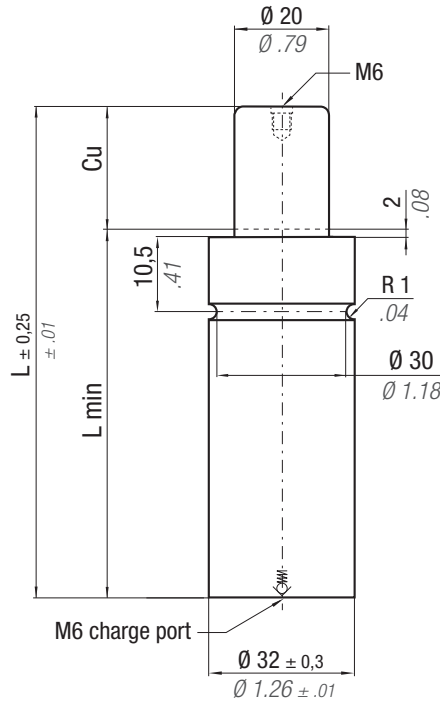

CODE	N ₂	°F 32 - 176	°C 0 - 80	ΔP ± 0,33 %/°C	P max 210 bar 3045 psi	P min 20 bar 290 psi	S 3,14 cm ² 0,487 in ²	SPM ~ 40 - 80 (at 20°C)	Max Speed 1,6 m/s	Maintenance kit 39BMMP02000A	Vo		PED		
											cm ³	in ³	~Kg	~lb	2014/68/EU
MQ 700 - 010 - A											12,0	0,73	0,29	0,64	✓
MQ 700 - 015 - A											15,0	0,92	0,31	0,68	✓
MQ 700 - 020 - A											18,0	1,10	0,33	0,73	✓
MQ 700 - 025 - A											21,0	1,28	0,35	0,77	✓
MQ 700 - 032 - A											26,0	1,59	0,38	0,84	✓
MQ 700 - 038 - A											32,0	1,95	0,41	0,90	✓
MQ 700 - 045 - A											36,0	2,20	0,44	0,97	✓
MQ 700 - 050 - A											39,0	2,38	0,46	1,01	✓
MQ 700 - 056 - A											45,0	2,75	0,49	1,08	✓
MQ 700 - 063 - A											52,0	3,17	0,53	1,17	✓
MQ 700 - 080 - A											63,0	3,84	0,60	1,32	✓

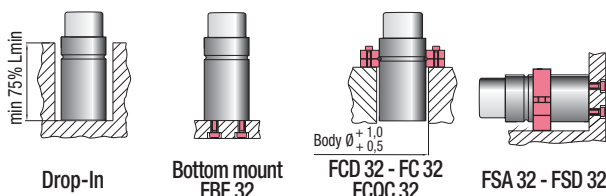

HOW TO ORDER

(10 pcs) MQ 700-050-A



THIS PAGE IS INTENTIONALLY LEFT BLANK

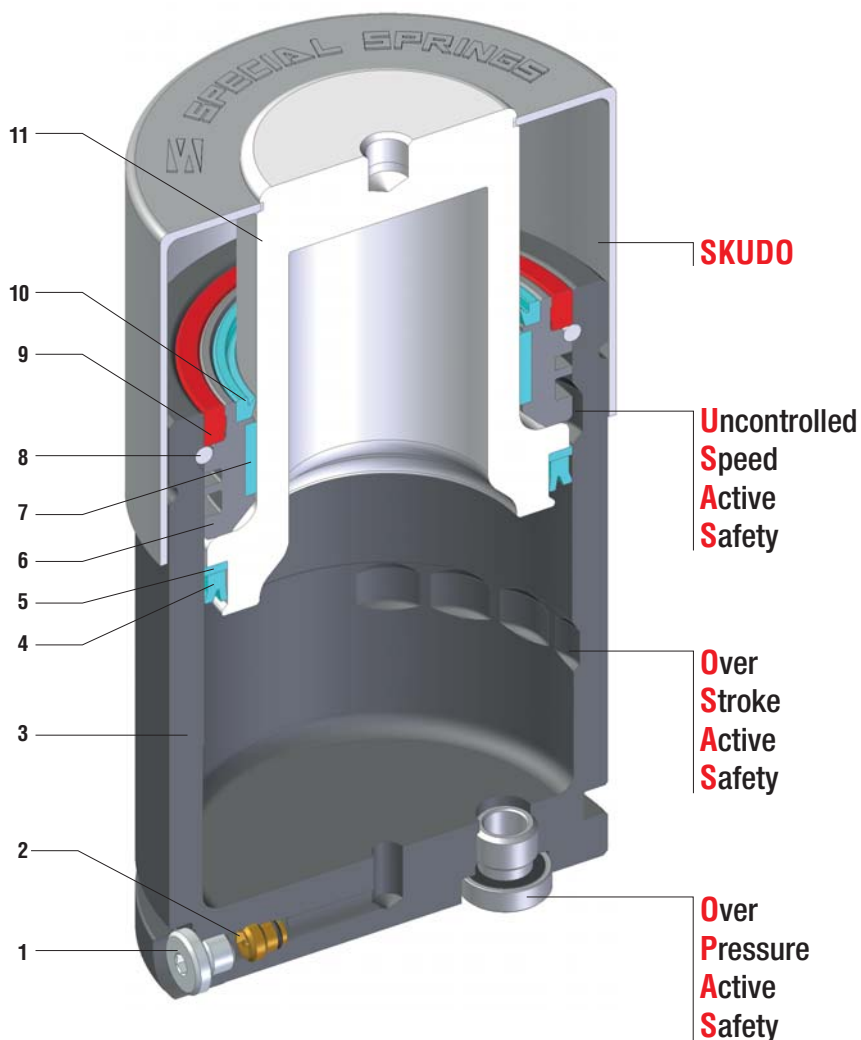

Massima forza, tenuta pistone + SKUDO - Maximum force, piston sealed + SKUDO - Maximale Kraft, Kolbendichtung + SKUDO - Force maximale, piston étanche + SKUDO - Máxima fuerza, estanqueidad pistón + SKUDO - Força máxima, estanquidade no pistão + SKUDO

SEALING	PISTON SEAL
DESIGN	PISTON - BODY DESIGN

1	Plug	5	Back-up ring	9	Outer seal
2	Valve	6	Bush	10	Rod wiper
3	Body	7	Guide ring	11	Rod (nitrited superfinished)
4	Piston seal	8	Retaining ring		

RANGE CHART

Model	Body Ø		Stroke Cu		Initial force F0					
	mm	inch	mm	inch	daN	lb				
KE 400	25	0.98	10 - 50	0.39 - 1.97	425	955	-	-	-	✓
KE 750	32	1.26	6 - 50	0.39 - 1.97	740	1664	✓	✓	✓	✓
KE 1000	38	1.50	6 - 50	0.24 - 1.97	1060	2383	✓	✓	✓	✓
KE 1800	50	1.97	6 - 65	0.24 - 1.97	1885	4238	✓	✓	✓	✓
KE 3000	63	2.48	10 - 65	0.39 - 1.97	2945	6620	✓	✓	✓	✓
KE 4700	75	2.95	10 - 65	0.39 - 1.97	4675	10510	✓	✓	✓	✓
KE 7500	95	3.74	10 - 65	0.39 - 1.97	7540	16950	✓	✓	✓	✓
KE 12000	120	4.72	10 - 65	0.39 - 1.97	11780	26481	✓	✓	✓	✓
KE 18500	150	5.91	10 - 65	0.39 - 1.97	18410	41386	✓	✓	✓	✓

HOW TO ORDER

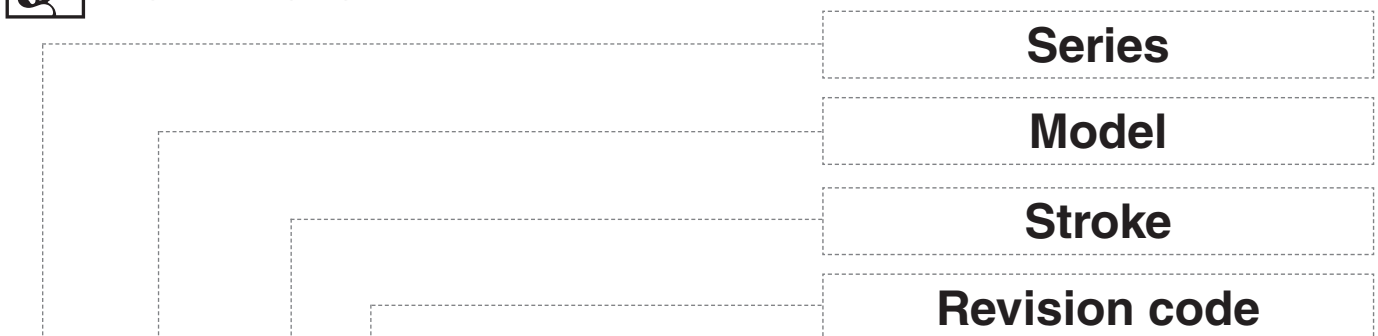

KE 1800-050-B - N - ED

- IT** Codice cilindro autonomo
- EN** Self-contained cylinder code
- DE** Kode des eingeständigen Gdf.
- FR** Code du cylindre autonome
- ES** Código del cilindro autónomo
- PT** Código do cilindro autónomo

- IT** Collegabile con tubi, cilindro fornito scarico e senza valvola unidirezionale
- EN** Linkable with hoses, cylinder supplied without pressure and oneway valve
- DE** Anschlussfähig mit Leitungen, Gdf. geliefert ohne Druck und RückschlagVentil
- FR** Connectable avec tubes, ressort fourni sans pression ni valve unidirectionelle
- ES** Connectable con tubos, cilindro suministrado sin presión y sin válvula unidireccional
- PT** Acompláveis com tubos, cilindro fornecidos sem pressão e sem válvula unidireccional

- IT** Collegabile EASY MANIFOLD, fornito scarico + guarnizione di collegamento
- EN** Linkable EASY MANIFOLD, supplied without pressure + connecting seal
- DE** Anschlussfähig EASY MANIFOLD, geliefert ohne Druck + Verbindungsdichtung
- FR** Connectable EASY MANIFOLD, fourni sans pression + joint de connexion
- ES** Connectable EASY MANIFOLD, suministrado sin presión + junta de conexión
- PT** Acompláveis EASY MANIFOLD, fornecidos sem pressão + vedantes de conexão

ACTIVE SAFETY



* $F_{1i} =$ Isothermal end force at 100% Cu p. 16 **** $F_{1p} =$ Polytrophic end force at 100% Cu**

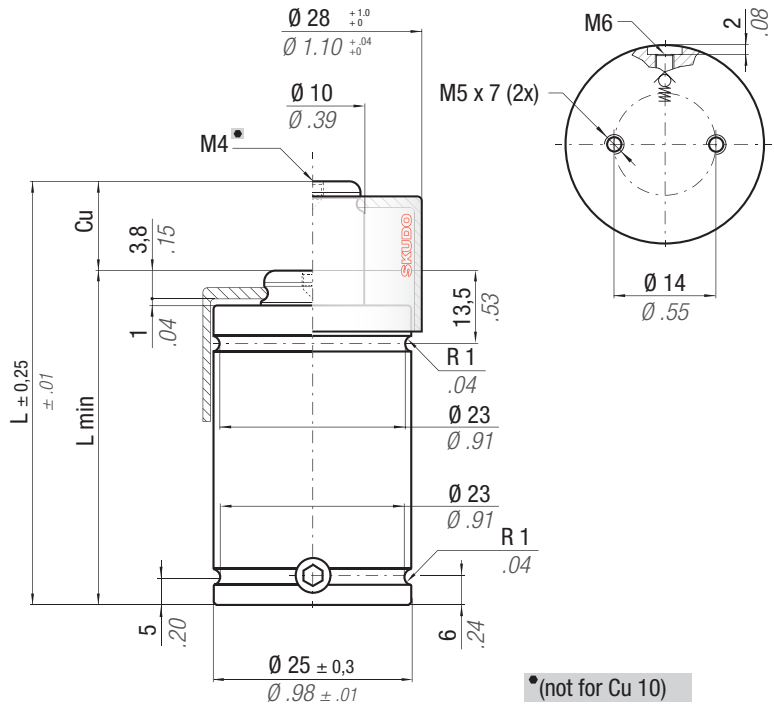

* (not for Cu 10)

CODE	Cu	L	L min	F ₀ Initial force	F _{1i} *		F _{1p} **		V ₀		Maintenance kit		
					daN	lb	daN	lb	daN	lb	cm ³	in ³	~Kg
KE 400 - 006 - A	6	56	50	425 955 ± 5% 150 bar 2175psi + 20 °C +68 °F	789	1774	1011	2273	4,0	0,24	0,13	0,29	✓
KE 400 - 010 - A	10	70	60		871	1958	1153	2592	6,0	0,37	0,16	0,35	✓
KE 400 - 016 - A	16	91	75		881	1981	1171	2633	10,0	0,61	0,18	0,40	✓
KE 400 - 025 - A	25	120	95		876	1969	1162	2612	16,0	0,98	0,23	0,51	✓
KE 400 - 032 - A	32	140	108		907	2040	1217	2736	19,0	1,16	0,24	0,53	✓
KE 400 - 040 - A	40	165	125		907	2039	1217	2736	24,0	1,46	0,28	0,62	✓
KE 400 - 050 - A	50	195	145		919	2065	1238	2783	30,0	1,83	0,31	0,68	✓

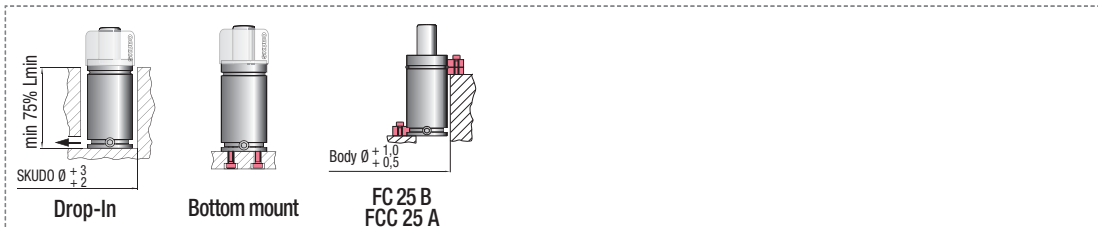
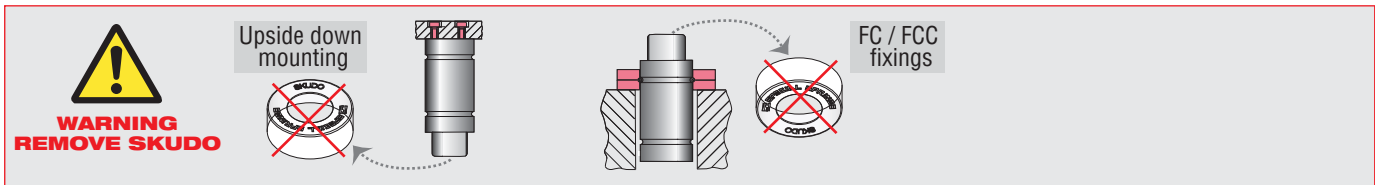

HOW TO ORDER
 (10 pcs) KE 400-050-A
 (10 pcs) KE 400-050-A-N

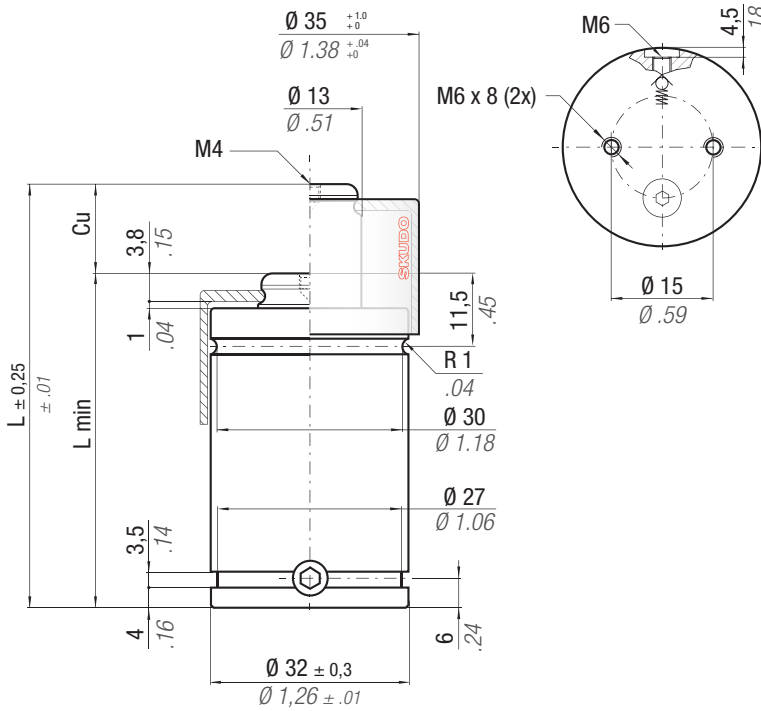

Il nuovo codice sarà fornito solo ad esaurimento del vecchio

The new code will be supplied only when the old will be out of stock

Der neue Kode wird geliefert nur wenn der alte nicht mehr im Lager ist

Le nouveau code sera fourni uniquement lorsque le vieux stock sera écoulé

El nuevo código será suministrado sólo cuando el viejo está fuera de stock

O novo código irá ser fornecido apenas quando o antigo esgotar stock

ACTIVE SAFETY



OSAS



USAS



OPAS



SKUDO

easu MANIFOLD p. 211

* $F_{1i} =$

Isothermal end force at 100% Cu p. 16

** $F_{1p} =$

Polytrophic end force at 100% Cu p. 16

		$^{\circ}\text{F}$ 32 176	$^{\circ}\text{C}$ 0 80	ΔP $\pm 0,33\% / ^{\circ}\text{C}$	P max 150 bar 2175 psi	P min 20 bar 290 psi	S 4,91 cm ² 0.761 in ²	SPM ~ 50 - 100 (at 20°C)	Max Speed 0,8 m/s	Maintenance kit 39BMKE00750B								
CODE		NEW		Cu	L	L min	F0	F_{1i} *		F_{1p} **		V0			PED 2014/68/EU			
PHASING OUT from 08/2012				mm	inch	mm	inch	daN	lb	daN	lb	daN	lb	cm ³	in ³	~Kg	~lb	✓
KE 750 - 006 - A	KE 750 - 006 - B	6	0.24	63	2.48	57	2.24	740	1664	1207	2714	1486	3341	9,0	0.55	0,23	0.51	✓
KE 750 - 010 - A	KE 750 - 010 - B	10	0.39	75	2.95	65	2.56	$\pm 5\%$		1310	2945	1656	3723	13,0	0.79	0,25	0.55	✓
KE 750 - 016 - A	KE 750 - 016 - B	16	0.63	93	3.66	77	3.03			1390	3125	1792	4029	19,0	1.16	0,29	0.64	✓
KE 750 - 025 - A	KE 750 - 025 - B	25	0.98	120	4.72	95	3.74	150 bar		1450	3259	1895	4260	28,0	1.71	0,33	0.73	✓
KE 750 - 032 - A	KE 750 - 032 - B	32	1.26	140	5.51	108	4.25	2175psi		1496	3363	1975	4440	35,0	2.14	0,37	0.82	✓
KE 750 - 040 - A	KE 750 - 040 - B	40	1.57	165	6.50	125	4.92			1496	3363	1975	4440	44,0	2.68	0,42	0.92	✓
KE 750 - 050 - A	KE 750 - 050 - B	50	1.97	195	7.68	145	5.71	+ 20 °C +68 °F		1513	3400	2004	4505	54,0	3.29	0,47	1.04	✓

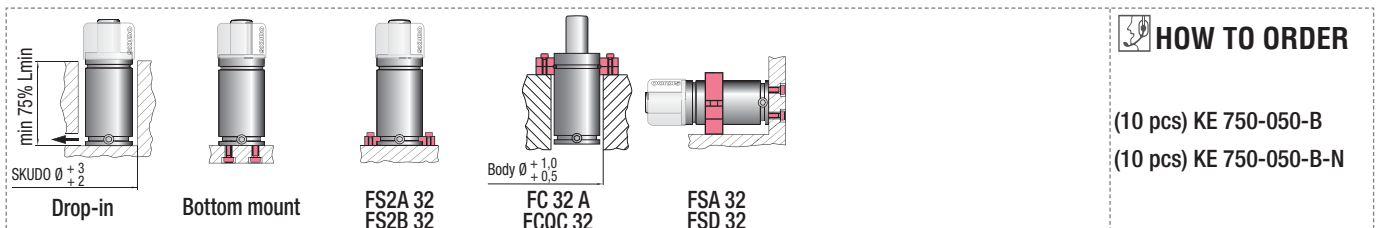
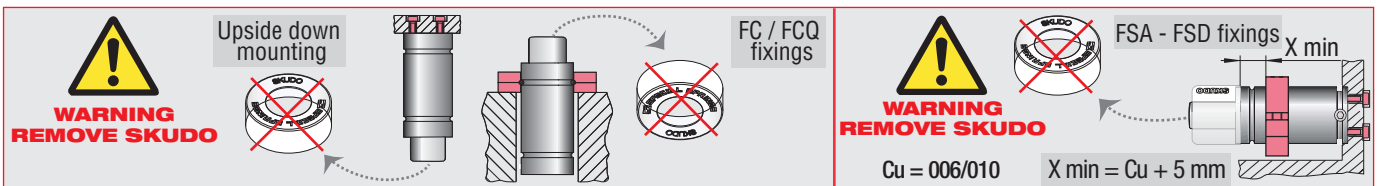

Il nuovo codice sarà fornito solo ad esaurimento del vecchio

The new code will be supplied only when the old will be out of stock

Der neue Kode wird geliefert nur wenn der alte nicht mehr im Lager ist

Le nouveau code sera fourni uniquement lorsque le vieux stock sera écoulé

El nuevo código será suministrado sólo cuando el viejo está fuera de stock

O novo código irá ser fornecido apenas quando o antigo esgotar stock

ACTIVE SAFETY



OSAS



USAS



OPAS



SKUDO

easu MANIFOLD p. 211

* $F_{1i} =$

Isothermal end force at 100% Cu p. 16

** $F_{1p} =$

Polytropic end force at 100% Cu

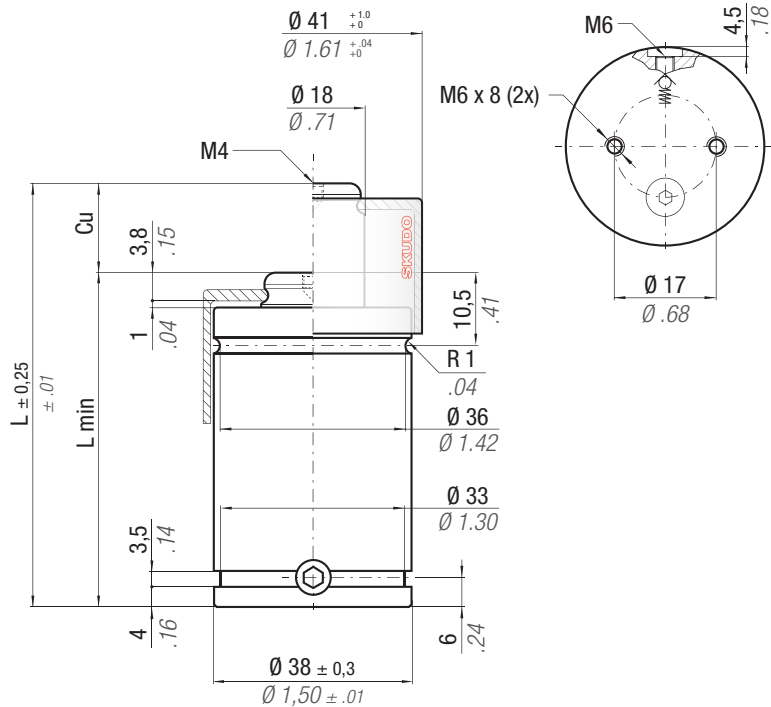

N₂	$^{\circ}F$ 32 -176	$^{\circ}C$ 0 -80	ΔP $\pm 0,33 \% / ^{\circ}C$	P max 150 bar 2175 psi	P min 20 bar 290 psi	S 7,07 cm ² 1.096 in ²	SPM ~ 50 - 100 (at 20°C)	Max Speed 0,8 m/s	Maintenance kit 39BMKE01000B
----------------------	---------------------------	-------------------------	---	-------------------------------------	-----------------------------------	---	---------------------------------------	-----------------------------	--

CODE PHASING OUT from 08/2012	NEW	Cu		L		L min		F ₀ Initial force		F _{1i} * End force *		F _{1p} ** End force **		V ₀		PED 2014/68/EU		
		mm	inch	mm	inch	mm	inch	daN	lb	daN	lb	daN	lb	cm ³	in ³		~Kg	~lb
KE 1000 - 006 - A	◆ KE 1000 - 006 - B	6	0.24	61	2.40	55	2.17	1060	2383	1902	4277	2412	5422	11,0	0.67	0,33	0.72	✓
KE 1000 - 010 - A	KE 1000 - 010 - B	10	0.39	78	3.07	68	2.68	$\pm 5\%$		1834	4123	2297	5164	19,0	1.16	0,38	0.84	✓
KE 1000 - 016 - A	KE 1000 - 016 - B	16	0.63	100	3.94	84	3.31			1814	4078	2264	5090	31,0	1.89	0,44	0.97	✓
KE 1000 - 025 - A	KE 1000 - 025 - B	25	0.98	135	5.31	110	4.33	150 bar 2175psi		1769	3977	2190	4923	51,0	3.11	0,53	1.17	✓
KE 1000 - 032 - A	KE 1000 - 032 - B	32	1.26	167	6.57	135	5.31			1701	3824	2079	4674	69,0	4.21	0,63	1.39	✓
KE 1000 - 040 - A	KE 1000 - 040 - B	40	1.57	195	7.68	155	6.10			1727	3883	2121	4768	84,0	5.12	0,70	1.54	✓
KE 1000 - 050 - A	KE 1000 - 050 - B	50	1.97	230	9.06	180	7.09	+ 20 °C +68 °F		1750	3934	2159	4854	103,0	6.28	0,79	1.74	✓

◆ Disposable

WARNING REMOVE SKUDO

Upside down mounting

FC / FCQ fixings

WARNING REMOVE SKUDO

FSA - FSD fixings X min

Cu = 006 / 010 X min = Cu + 5 mm

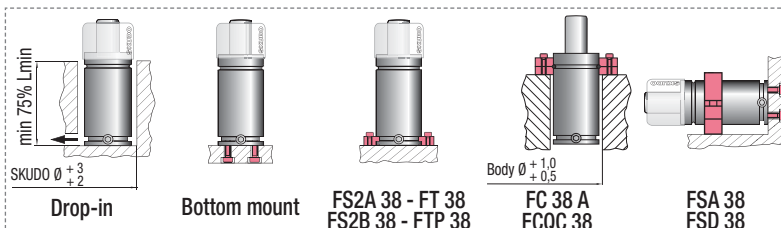

HOW TO ORDER

(10 pcs) KE 1000-050-B
(10 pcs) KE 1000-050-B-N

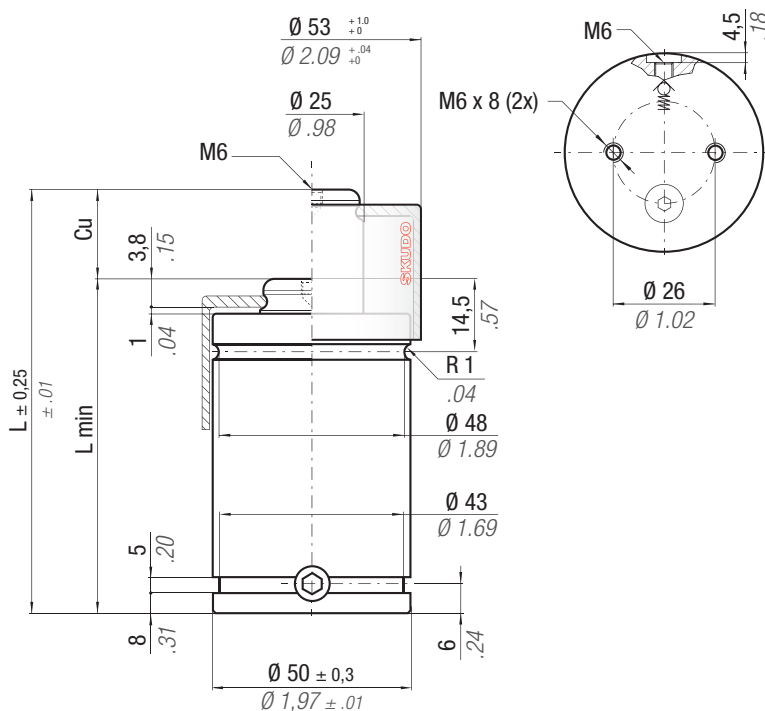

Il nuovo codice sarà fornito solo ad esaurimento del vecchio

The new code will be supplied only when the old will be out of stock

Der neue Kode wird geliefert nur wenn der alte nicht mehr im Lager ist

Le nouveau code sera fourni uniquement lorsque le vieux stock sera écoulé

El nuevo código será suministrado sólo cuando el viejo está fuera de stock

O novo código irá ser fornecido apenas quando o antigo esgotar stock

ACTIVE SAFETY



OSAS



USAS



OPAS



SKUDO

easu MANIFOLD p. 211

* $F_{1i} =$

Isothermal end force at 100% Cu p. 16

** $F_{1p} =$

Polytrophic end force at 100% Cu

N₂		°F 32 - 176	°C 0 - 80	ΔP ± 0,33 %/°C	P max 150 bar 2175 psi	P min 20 bar 290 psi	S 12,57 cm ² 1.948 in ²	SPM ~ 50 - 100 (at 20°C)	Max Speed 0,8 m/s	Maintenance kit 39BMKE01800B
CODE	Cu	L	L min	F₀	F_{1i} *	F_{1p} **	V₀	PED 2014/68/EU		
PHASING OUT from 08/2012	NEW	mm inch	mm inch	mm inch	daN lb	daN lb	cm ³ in ³	~Kg ~lb	✓	
KE 1800 - 006 - A	KE 1800 - 006 - B	6 0.24	66 2.60	60 2.36	1885 4238 ± 5%	3046 6847	3731 8388	23,0 1.40	0,63 1.39	✓
KE 1800 - 010 - A	KE 1800 - 010 - B	10 0.39	80 3.15	70 2.76		3125 7026	3860 8678	36,0 2.20	0,69 1.52	✓
KE 1800 - 016 - A	KE 1800 - 016 - B	16 0.63	106 4.17	90 3.54	150 bar 2175psi	2979 6698	3623 8145	63,0 3.84	0,81 1.79	✓
KE 1800 - 025 - A	KE 1800 - 025 - B	25 0.98	135 5.31	110 4.33		3133 7044	3874 8709	90,0 5.49	0,94 2.07	✓
KE 1800 - 032 - A	KE 1800 - 032 - B	32 1.26	162 6.38	130 5.12	+ 20 °C +68 °F	3106 6983	3830 8610	117,0 7.14	1,06 2.34	✓
KE 1800 - 040 - A	KE 1800 - 040 - B	40 1.57	190 7.48	150 5.91		3135 7049	3877 8716	145,0 8.85	1,19 2.62	✓
KE 1800 - 050 - A	KE 1800 - 050 - B	50 1.97	220 8.66	170 6.69	3236 7275	4043 9089	172,0 10.49	1,31 2.89	✓	
-	KE 1800 - 065 - B	65 2.56	271 10.67	206 8.11	3262 7333	4086 9186	221,0 13.48	1,53 3.37	✓	

WARNING REMOVE SKUDO

Upside down mounting

FC / FCQ fixings

WARNING REMOVE SKUDO

FSA - FSD fixings X min

Cu = 006 / 010 X min = Cu + 5 mm

Drop-in

Bottom mount

FS2 50 - FT 50
FS2A 50 - FTP 50

FCB 50 - FCQB 50

FSA 50

FSD 50 - FSE 50

FSD 50 + R 50 A
FSE 50 + R 50 A

HOW TO ORDER

(10 pcs) KE 1800-050-B
(10 pcs) KE 1800-050-B-N

Il nuovo codice sarà fornito solo ad esaurimento del vecchio

The new code will be supplied only when the old will be out of stock

Der neue Kode wird geliefert nur wenn der alte nicht mehr im Lager ist

Le nouveau code sera fourni uniquement lorsque le vieux stock sera écoulé

El nuevo código será suministrado sólo cuando el viejo está fuera de stock

O novo código irá ser fornecido apenas quando o antigo esgotar stock

ACTIVE SAFETY



OSAS



USAS



OPAS



SKUDO

easu MANIFOLD p. 211

* F_{1i} =

Isothermal end force at 100% Cu p. 16

** F_{1p} =

Polytropic end force at 100% Cu

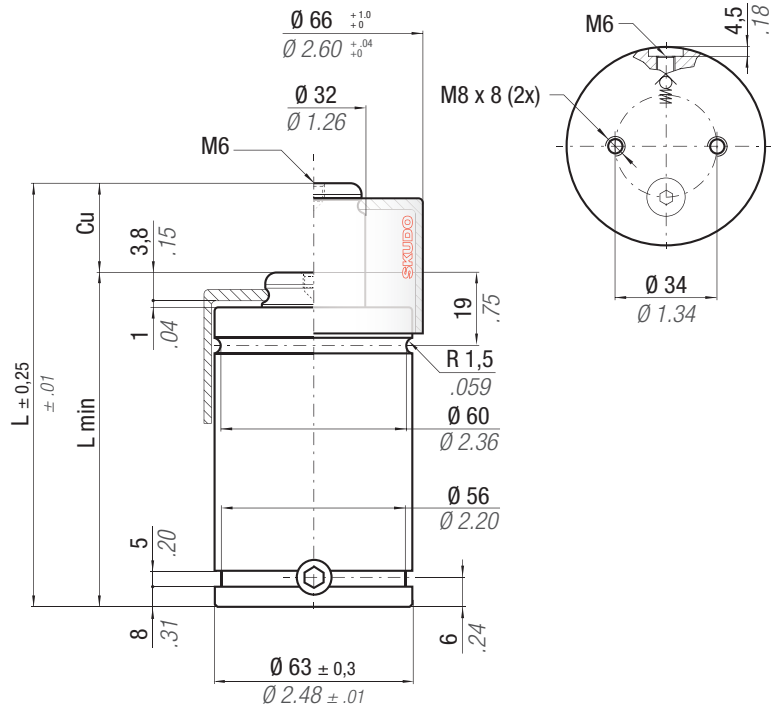

N₂	$^{\circ}F$ 32 - 176	$^{\circ}C$ 0 - 80	ΔP $\pm 0,33 \%/^{\circ}C$	P max 150 bar 2175 psi	P min 20 bar 290 psi	S 19,63 cm ² 3.043 in ²	SPM ~ 80 - 100 (at 20°C)	Max Speed 0,8 m/s	Maintenance kit 39BMKE03000B
----------------------	-------------------------------	-----------------------------	---------------------------------------	-------------------------------------	-----------------------------------	--	---------------------------------------	-----------------------------	--

CODE PHASING OUT from 08/2012	NEW	Cu		L		L min		F ₀ Initial force		F _{1i} * End force *		F _{1p} ** End force **		V ₀		~Kg	~lb	PED 2014/68/EU
		mm	inch	mm	inch	mm	inch	daN	lb	daN	lb	daN	lb	cm ³	in ³			
KE 3000 - 010 - A	KE 3000 - 010 - B	10	0.39	85	3.35	75	2.95	2945 6620 $\pm 5\%$ 150 bar 2175psi $+ 20^{\circ}C +68^{\circ}F$	5084	11429	6363	14305	53,0	3.23	1,23	2.71	✓	
KE 3000 - 016 - A	KE 3000 - 016 - B	16	0.63	103	4.06	87	3.43		5362	12053	6829	15352	79,0	4.82	1,36	3.00	✓	
KE 3000 - 025 - A	KE 3000 - 025 - B	25	0.98	130	5.12	105	4.13		5566	12512	7176	16132	119,0	7.26	1,55	3.42	✓	
KE 3000 - 032 - A	KE 3000 - 032 - B	32	1.26	150	5.91	118	4.65		5721	12861	7443	16733	147,0	8.97	1,69	3.73	✓	
KE 3000 - 040 - A	KE 3000 - 040 - B	40	1.57	175	6.89	135	5.31		5722	12863	7445	16737	184,0	11.22	1,86	4.10	✓	
KE 3000 - 050 - A	KE 3000 - 050 - B	50	1.97	205	8.07	155	6.10	5778	12989	7542	16955	227,0	13.85	2,07	4.56	✓		
-	KE 3000 - 065 - B	65	2.56	256	10.08	191	7.52	5630	12657	7287	16382	304,0	18.54	2,44	5.38	✓		

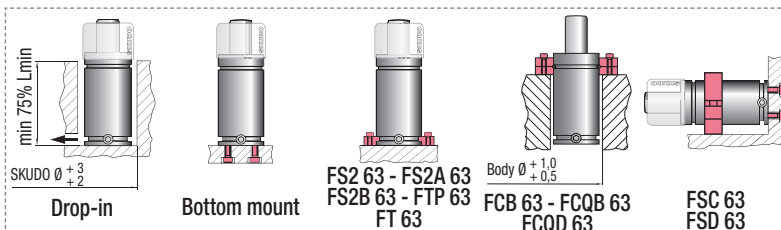
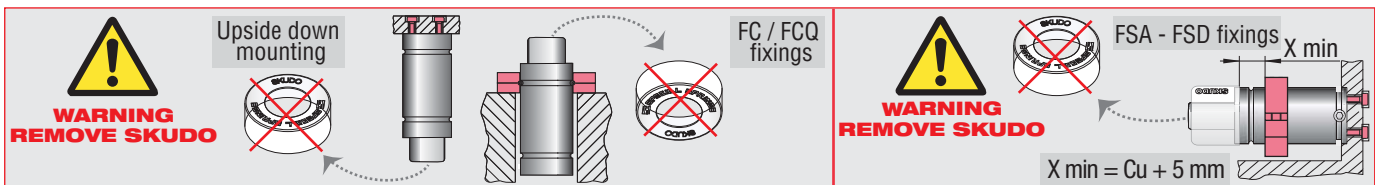

HOW TO ORDER

(10 pcs) KE 3000-050-B
(10 pcs) KE 3000-050-B-N

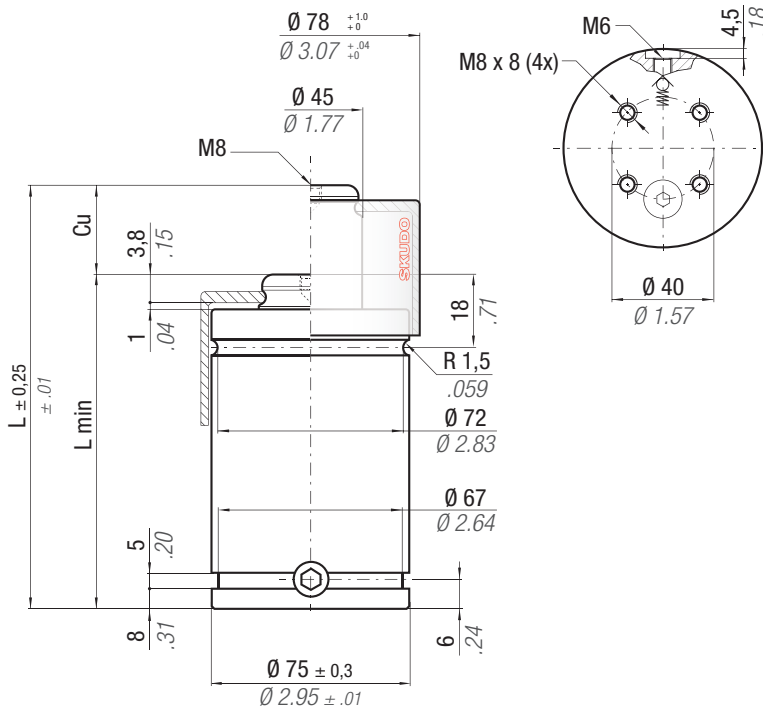

Il nuovo codice sarà fornito solo ad esaurimento del vecchio

The new code will be supplied only when the old will be out of stock

Der neue Kode wird geliefert nur wenn der alte nicht mehr im Lager ist

Le nouveau code sera fourni uniquement lorsque le vieux stock sera écoulé

El nuevo código será suministrado sólo cuando el viejo está fuera de stock

O novo código irá ser fornecido apenas quando o antigo esgotar stock

ACTIVE SAFETY



OSAS



USAS



OPAS



SKUDO

easu MANIFOLD p. 211

* $F_{1i} =$

Isothermal end force at 100% Cu p. 16

** $F_{1p} =$

Polytrophic end force at 100% Cu

		$^{\circ}F$ 32 - 176	$^{\circ}C$ 0 - 80	ΔP $\pm 0,33\% / ^{\circ}C$	P max 150 bar 2175 psi	P min 20 bar 290 psi	S 31,17 cm ² 4.831 in ²	SPM ~ 80 - 100 (at 20°C)	Max Speed 0,8 m/s	Maintenance kit 39BMKE04700B				
CODE	NEW	Cu	L	L min	F₀		F_{1i} *		F_{1p} **		V₀			
PHASING OUT from 08/2012		mm inch	mm inch	mm inch	Initial force	daN lb	daN lb	daN lb	daN lb	cm ³ in ³	~Kg ~lb	2014/68/EU	✓	
KE 4700 - 010 - A	KE 4700 - 010 - B	10 0.39	80 3.15	70 2.76	4675 10510 $\pm 5\%$	8017 18023	7467 16788	9112 20485	153,0 9.33	1,62 3.57	✓			
KE 4700 - 016 - A	KE 4700 - 016 - B	16 0.63	106 4.17	90 3.54			7780 17491	9622 21631	224,0 13.66	2,10 4.63	✓			
KE 4700 - 025 - A	KE 4700 - 025 - B	25 0.98	135 5.31	110 4.33	150 bar 2175psi	7447 16742	9079 20410	308,0 18.79	2,39 5.27	✓				
KE 4700 - 032 - A	KE 4700 - 032 - B	32 1.26	167 6.57	135 5.31		7360 16547	8939 20096	393,0 23.97	2,68 5.91	✓				
KE 4700 - 040 - A	KE 4700 - 040 - B	40 1.57	200 7.87	160 6.30	+ 20 °C +68 °F	7326 16469	8883 19970	496,0 30.26	3,03 6.68	✓				
KE 4700 - 050 - A	KE 4700 - 050 - B	50 1.97	240 9.45	190 7.48		7926 17818	9862 22171	565,0 34.47	3,30 7.28	✓				
-	KE 4700 - 65 - B	65 2.56	273 10.75	208 8.19						✓				

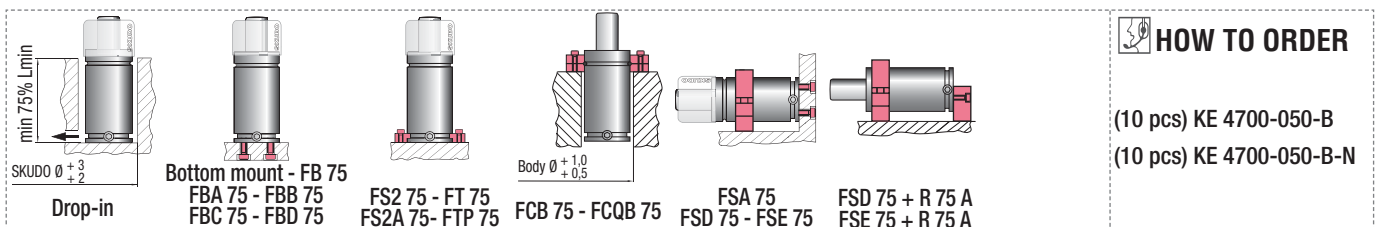
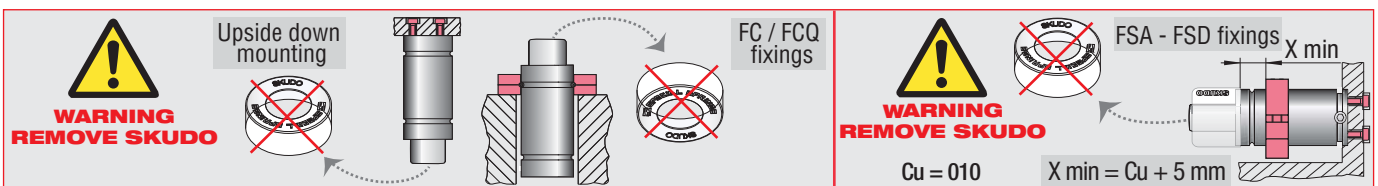

Il nuovo codice sarà fornito solo ad esaurimento del vecchio

The new code will be supplied only when the old will be out of stock

Der neue Kode wird geliefert nur wenn der alte nicht mehr im Lager ist

Le nouveau code sera fourni uniquement lorsque le vieux stock sera écoulé

El nuevo código será suministrado sólo cuando el viejo está fuera de stock

O novo código irá ser fornecido apenas quando o antigo esgotar stock

ACTIVE SAFETY



OSAS



USAS



OPAS



SKUDO

easu MANIFOLD p. 211

* $F_{1i} =$

Isothermal end force at 100% Cu p. 16

** $F_{1p} =$

Polytrophic end force at 100% Cu

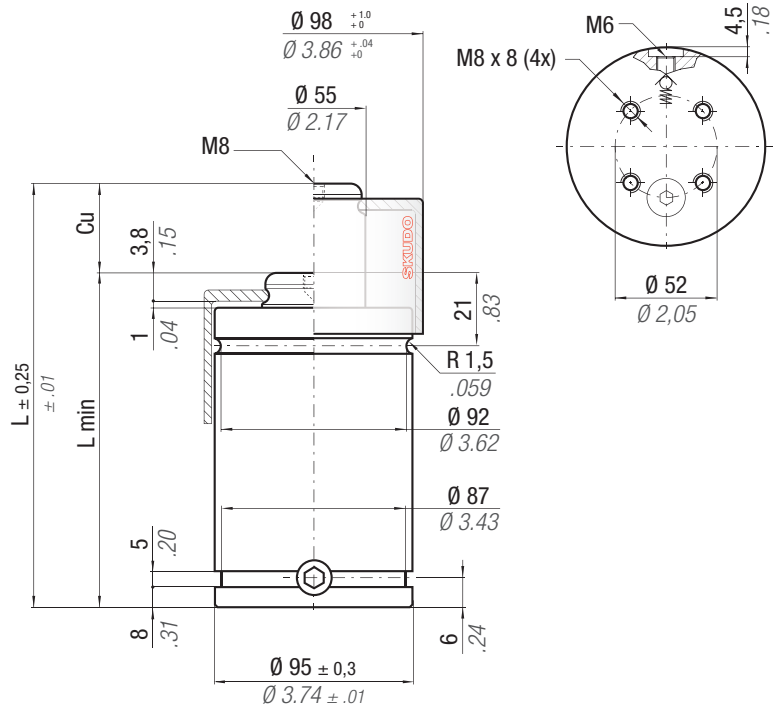

N ₂	$^{\circ}F$ 32 - 176	$^{\circ}C$ 0 - 80	ΔP $\pm 0,33 \%/^{\circ}C$	P max 150 bar 2175 psi	P min 20 bar 290 psi	S 50,27 cm ² 7.791 in ²	SPM ~ 80 - 100 (at 20°C)	Max Speed 0,8 m/s	Maintenance kit 39BMKE07500B
----------------	-------------------------------	-----------------------------	---------------------------------------	-------------------------------------	-----------------------------------	--	---------------------------------------	-----------------------------	--

CODE PHASING OUT from 08/2012	NEW	Cu		L		L min		F ₀		F _{1i} *		F _{1p} **		V ₀		~Kg	~lb	PED 2014/68/EU
		mm	inch	mm	inch	mm	inch	daN	lb	daN	lb	daN	lb	cm ³	in ³			
KE 7500 - 010 - A	KE 7500 - 010 - B	10	0.39	90	3.54	80	3.15	7540	16950	11910	26775	14481	32555	158,0	9.64	2,89	6.37	✓
KE 7500 - 016 - A	KE 7500 - 016 - B	16	0.63	116	4.57	100	3.94			11563	25995	13924	31302	266,0	16.23	3,26	7.19	✓
KE 7500 - 025 - A	KE 7500 - 025 - B	25	0.98	145	5.71	120	4.72	150 bar 2175psi	± 5%	12169	27357	14901	33499	379,0	23.12	3,64	8.02	✓
KE 7500 - 032 - A	KE 7500 - 032 - B	32	1.26	182	7.17	150	5.91			11486	25821	13800	31024	540,0	32.94	4,18	9.22	✓
KE 7500 - 040 - A	KE 7500 - 040 - B	40	1.57	210	8.27	170	6.69	+ 20 °C +68 °F		11697	26297	14138	31783	652,0	39.77	4,56	10.05	✓
KE 7500 - 050 - A	KE 7500 - 050 - B	50	1.97	255	10.04	205	8.07			11502	25857	13825	31080	841,0	51.30	5,19	11.44	✓
-	KE 7500 - 065 - B	65	2.56	279	10.98	214	8.43	12826	28834	15978	35920	907,0	55.33	5,46	12.40	✓		

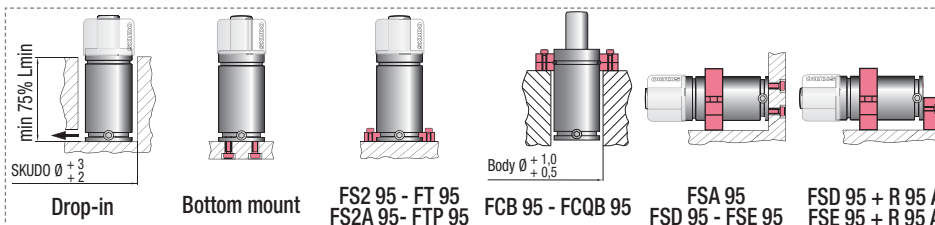
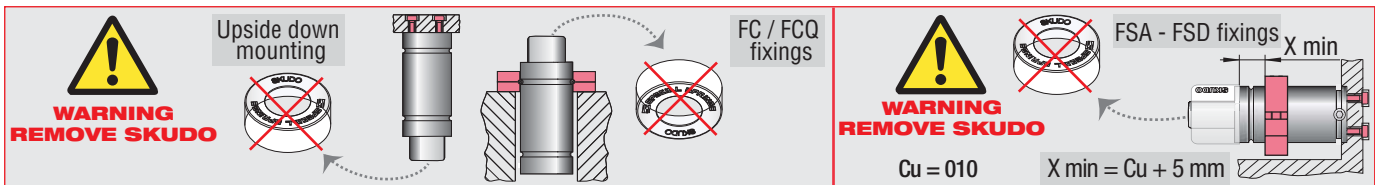

HOW TO ORDER

(10 pcs) KE 7500-050-B
(10 pcs) KE 7500-050-B-N

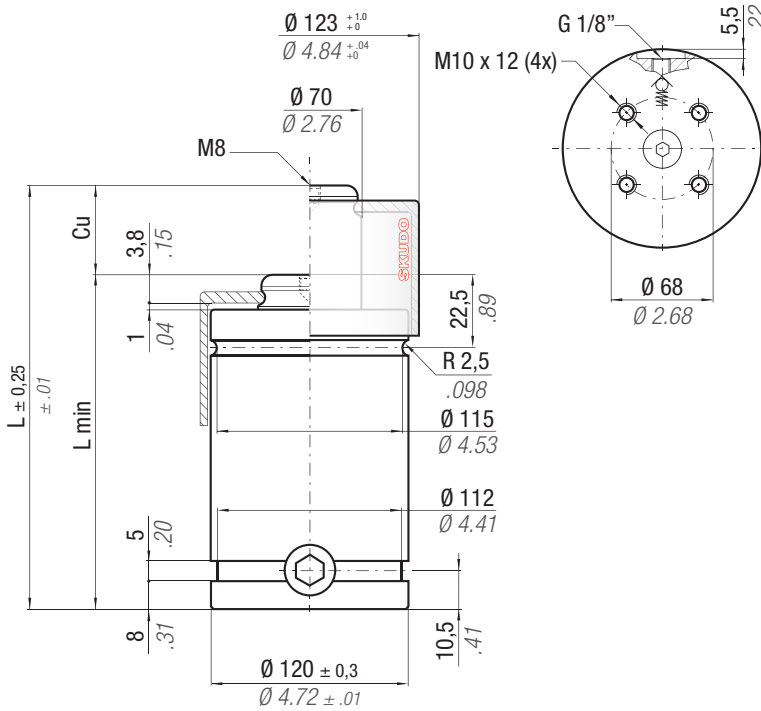

Il nuovo codice sarà fornito solo ad esaurimento del vecchio

The new code will be supplied only when the old will be out of stock

Der neue Kode wird geliefert nur wenn der alte nicht mehr im Lager ist

Le nouveau code sera fourni uniquement lorsque le vieux stock sera écoulé

El nuevo código será suministrado sólo cuando el viejo está fuera de stock

O novo código irá ser fornecido apenas quando o antigo esgotar stock

ACTIVE SAFETY



OSAS



USAS



OPAS



SKUDO

easu MANIFOLD p. 211

* $F_{1i} =$

Isothermal end force at 100% Cu p. 16

** $F_{1p} =$

Polytrophic end force at 100% Cu

		°F 32 - 176	°C 0 - 80	ΔP ± 0,33 %/°C	P max 150 bar 2175 psi	P min 20 bar 290 psi	S 78,54 cm ² 12.174 in ²	SPM ~ 50 - 100 (at 20°C)	Max Speed 0,8 m/s	Maintenance kit 39BMKE12000B
CODE	NEW	Cu	L	L min	F0	F _{1i} *	F _{1p} **	V0		
PHASING OUT from 08/2012		mm inch	mm inch	mm inch	Initial force daN lb	daN lb	daN lb	cm ³ in ³	~Kg ~lb	
KE 12000 - 010 - A	KE 12000 - 010 - B	10 0.39	100 3.94	90 3,54	11780 26482 ± 5% 150 bar 2175psi + 20 °C +68 °F	17843 40113	21398 48105	267,0 16.29	5,49 12.10	✓
KE 12000 - 016 - A	KE 12000 - 016 - B	16 0.63	126 4.96	110 4,33		17646 39670	21084 47399	436,5 26.63	6,11 13.47	✓
KE 12000 - 025 - A	KE 12000 - 025 - B	25 0.98	155 6.10	130 5,12		18657 41943	22704 51041	613,0 37.39	6,76 14.90	✓
KE 12000 - 032 - A	KE 12000 - 032 - B	32 1.26	187 7.36	155 6,10		18166 40838	21913 49262	824,0 50.26	7,54 16.62	✓
KE 12000 - 040 - A	KE 12000 - 040 - B	40 1.57	220 8.66	180 7,09		18098 40687	21805 49020	1037,0 63.26	8,31 18.32	✓
KE 12000 - 050 - A	KE 12000 - 050 - B	50 1.97	260 10.24	210 8,27		18116 40727	21834 49085	1294,0 78.93	9,25 20.9	✓
-	KE 12000 - 065 - B	65 2.56	320 12.60	255 10,04	18133 40765	21860 49143	1679,0 102.42	10,66 23.50	✓	

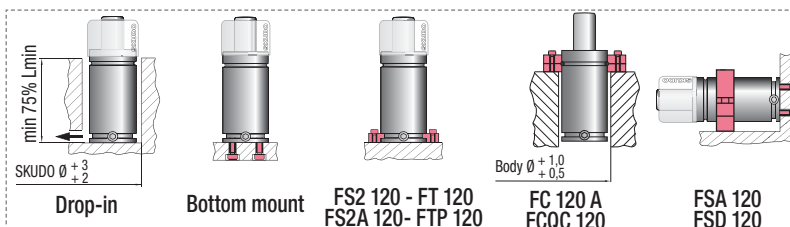
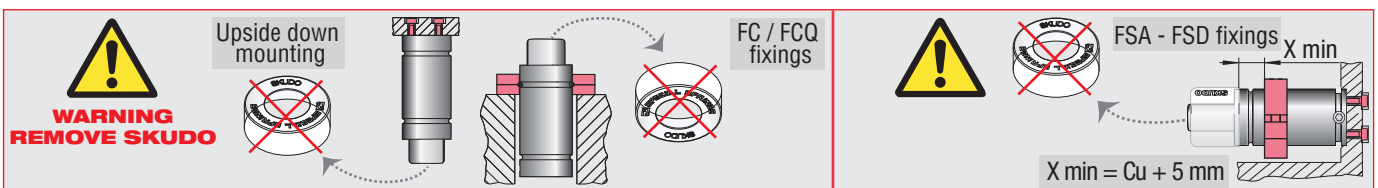

HOW TO ORDER

(10 pcs) KE 12000-050-B
(10 pcs) KE 12000-050-B-N

ACTIVE SAFETY



OSAS



USAS



OPAS



SKUDO

Il nuovo codice sarà fornito solo ad esaurimento del vecchio

The new code will be supplied only when the old will be out of stock

Der neue Kode wird geliefert nur wenn der alte nicht mehr im Lager ist

Le nouveau code sera fourni uniquement lorsque le vieux stock sera écoulé

El nuevo código será suministrado sólo cuando el viejo está fuera de stock

O novo código irá ser fornecido apenas quando o antigo esgotar stock

easu MANIFOLD p. 211

* F_{1i} =

Isothermal end force at 100% Cu p. 16

** F_{1p} =

Polytrophic end force at 100% Cu

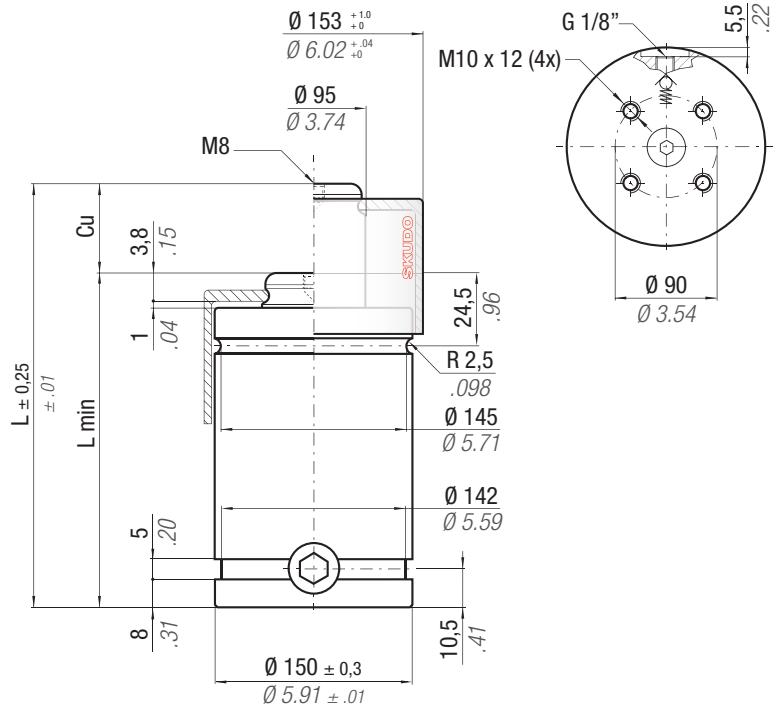

	$^{\circ}\text{F}$ 32 -176	$^{\circ}\text{C}$ 0 -80	ΔP ± 0,33 %/°C	P max 150 bar 2175 psi	P min 20 bar 290 psi	S 122,72 cm ² 19.022 in ²	SPM ~ 50 - 100 (at 20°C)	Max Speed 0,8 m/s	Maintenance kit 39BMKE18500B
--	----------------------------------	--------------------------------	---------------------------------	-------------------------------------	-----------------------------------	--	---------------------------------------	-----------------------------	--

CODE PHASING OUT from 08/2012	NEW	Cu		L		L min		F ₀		F _{1i} *		F _{1p} **		V ₀		~Kg	~lb	PED 2014/68/EU
		mm	inch	mm	inch	mm	inch	daN	lb	daN	lb	daN	lb	cm ³	in ³			
KE 18500 - 010 - A	KE 18500 - 010 - B	10	0.39	110	4.33	100	3.94	18410 41386 ± 5%	25880 58181	30288 68090	493,0 30.07	9,31 20.53	✓					
KE 18500 - 016 - A	KE 18500 - 016 - B	16	0.63	136	5.35	120	4.72							26201 58903	30788 69214	765,0 46.67	10,28 22.66	✓
KE 18500 - 025 - A	KE 18500 - 025 - B	25	0.98	165	6.50	140	5.51											
KE 18500 - 032 - A	KE 18500 - 032 - B	32	1.26	197	7.76	165	6.50	150 bar 2175psi	27347 61479	32588 73261	1388,0 84.67	12,51 27.58	✓					
KE 18500 - 040 - A	KE 18500 - 040 - B	40	1.57	235	9.25	195	7.68							26947 60580	31957 71842	1791,0 109.25	13,93 30.71	✓
KE 18500 - 050 - A	KE 18500 - 050 - B	50	1.97	270	10.63	220	8.66	+ 20 °C +68 °F	27505 61833	32838 73823	2142,0 130.66	15,19 33.49	✓					
-	KE 18500 - 065 - B	65	2.56	323	12.72	258	10.16							28055 63070	33713 75790	2674,0 163.11	17,10 37.70	✓

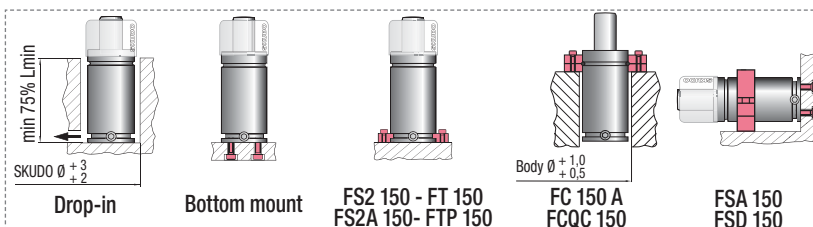
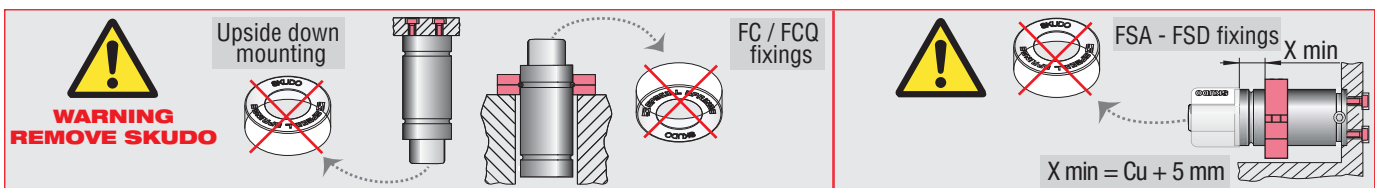

HOW TO ORDER

(10 pcs) KE 18500-050-B
(10 pcs) KE 18500-050-B-N



THIS PAGE IS INTENTIONALLY LEFT BLANK

IT La seguente tabella indica i riferimenti Special Springs per ogni standards. Vedi esempio sotto riportato.

EN The following table shows the references for each Special Springs standards. See example below.

DE Die folgende Tabelle zeigt die Verweise für jede Special Springs Standards. Siehe Beispiel unten.

FR Le tableau suivant indique les références pour chacune des normes spéciales Springs. Voir l'exemple ci-dessous.

ES La siguiente tabla muestra las referencias de las normas especiales para cada Springs. Consulte el siguiente ejemplo.

PT A tabela a seguir mostra as referências para cada normas especiais molas. Veja o exemplo abaixo.

Reference to standards	Standards	
0	//	Special Springs
1	ISO 11901-2	
2	VDI 3003	
3	B2 4009	BMW
4	W-DX35-62M	Ford
5	W-DX35-80M	Ford
6	W-DX40-80M	Ford
7	90.25.01	General Motors
8	90.25.02	General Motors
9	90.25.03	General Motors
10	90.25.04	General Motors
11	90.25.06	General Motors
12	90.25.07	General Motors
13	90.25.455	General Motors
14	B8 0132 110 008 801	Mercedes Benz

Reference to standards	Standards	
15	B8 0138 100 000 001	Mercedes Benz
16	B8 0134 300 000 001	Mercedes Benz
17	B8 0134 400 008 801	Mercedes Benz
18	B8	Mercedes Benz
19	E24.54.815.G	Peugeot - Citroën
20	EM24.54.700	Renault
21	39D 848	Volkswagen
22	075.90.70	FCA
23	075.90.75	FCA
24	075.90.80	FCA
25	075.90.85	FCA
26	075.90.90	FCA
27	075.90.95	FCA
28	075.90.40	FCA

How to read the table

CODE	Reference to standards	A		B		Ø C		D		Ø E		Ø F		Ø G		Ø H		I		L	
		mm	inch	mm	inch	mm	inch	mm	inch	mm	inch	mm	inch	mm	inch	mm	inch	mm	inch	mm	inch
FB 45	1-2-10-19-20	70	2.76	50	1.97	20	0.79	20	0.79	15	0.59	15	0.59	9	0.35	9	0.35	14	0.55	12	0.47

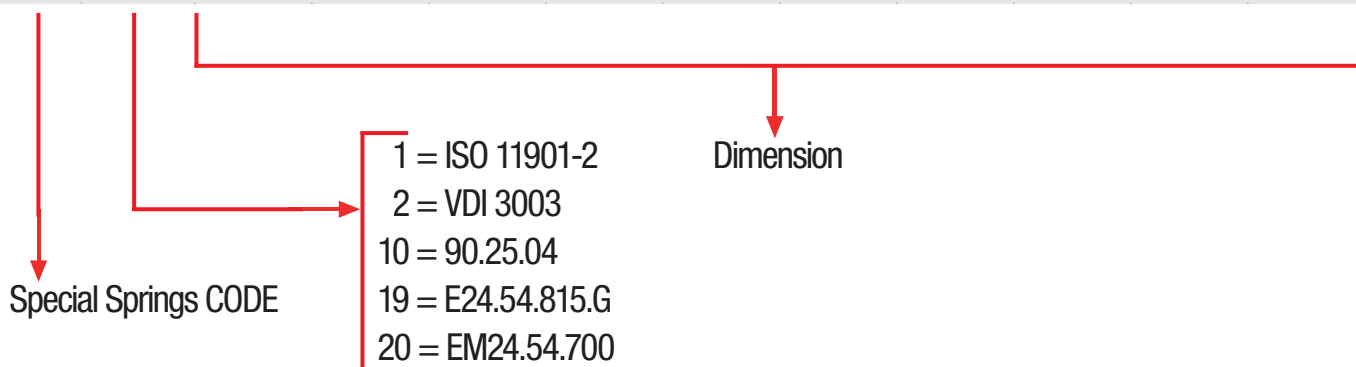

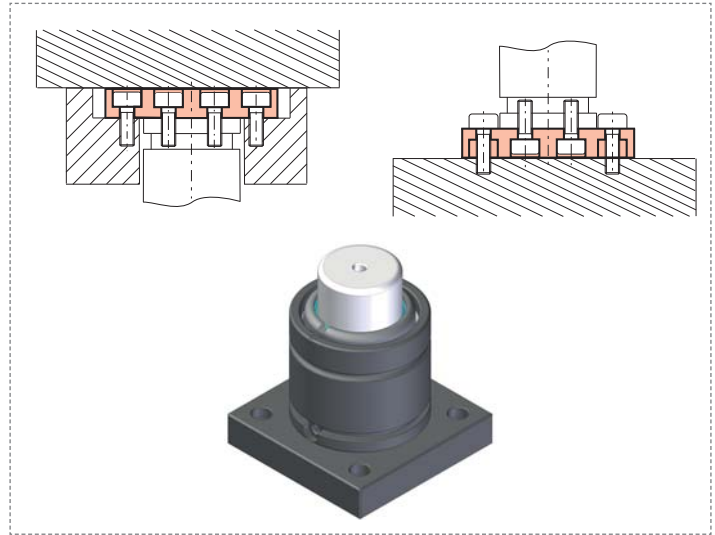
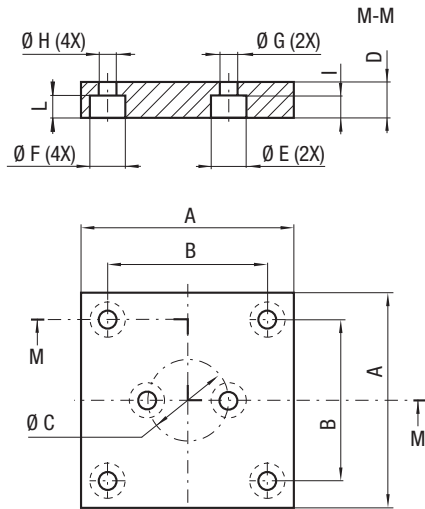

CODE	Reference to standards	A		B		Ø C		D		Ø E		Ø F		Ø G		Ø H		I		L	
		mm	inch	mm	inch	mm	inch	mm	inch	mm	inch	mm	inch	mm	inch	mm	inch	mm	inch	mm	inch
FB 45	1-2-10-19-20	70	2.76	50	1.97	20	0.79	20	0.79	15	0.59	15	0.59	9	0.35	9	0.35	14	0.55	12	0.47
FB 50	1-2-10-19-20	75	2.95	56,5	2.22	20	0.79	20	0.79	15	0.59	15	0.59	9	0.35	9	0.35	14	0.55	12	0.47
FB 63	0	100	3.94	73,5	2.89	20	0.79	20	0.79	15	0.59	18	0.71	9	0.35	11	0.43	12	0.47	12	0.47

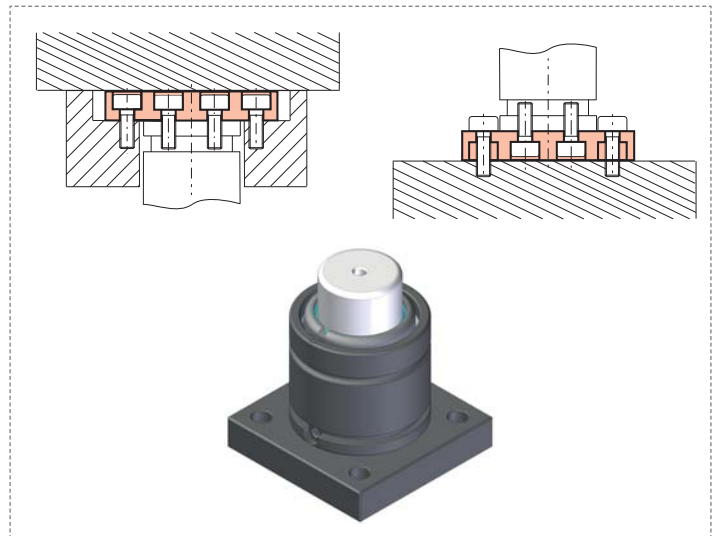
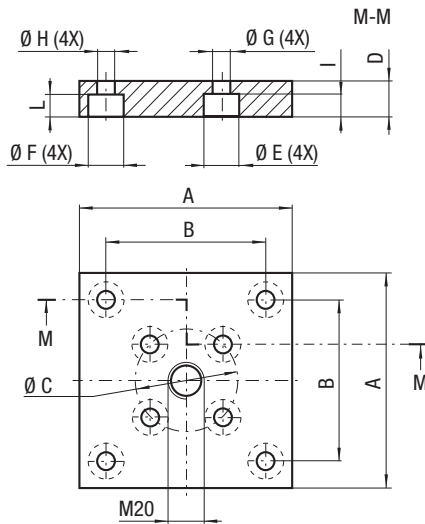

CODE	Reference to standards	A		B		Ø C		D		Ø E		Ø F		Ø G		Ø H		I		L	
		mm	inch	mm	inch	mm	inch	mm	inch	mm	inch	mm	inch	mm	inch	mm	inch	mm	inch	mm	inch
FB 75	1-2-10-19-20	100	3.94	73,5	2.89	40	1.57	20	0.79	15	0.59	18	0.71	9	0.35	11	0.43	14	0.55	12	0.47
FB 95	1-2-10-19-20	120	4.72	92	3.62	60	2.36	20	0.79	15	0.59	20	0.79	9	0.35	13,5	0.53	14	0.55	13	0.51
FB 120	1-2-10-19-20	140	5.51	109,5	4.31	80	3.15	20	0.79	18	0.71	20	0.79	11	0.43	13,5	0.53	15	0.59	13	0.51
FB 150	1-2-10-20	190	7.48	138	5.43	100	3.94	25	0.98	18	0.71	26	1.02	11	0.43	17,5	0.69	15	0.59	17	0.67
FB 195	1-2-10-20	210	8.27	170	6.69	120	4.72	25	0.98	20	0.79	26	1.02	13,5	0.53	17,5	0.69	13	0.51	17	0.67

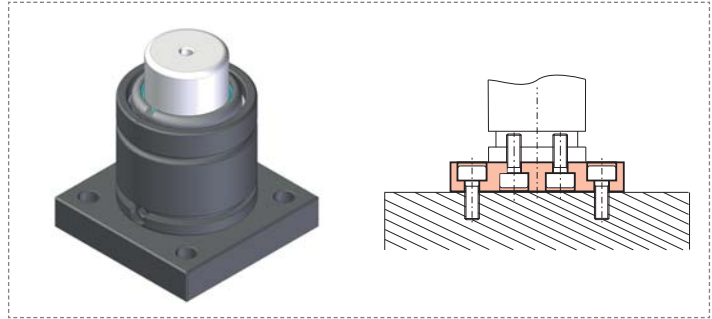
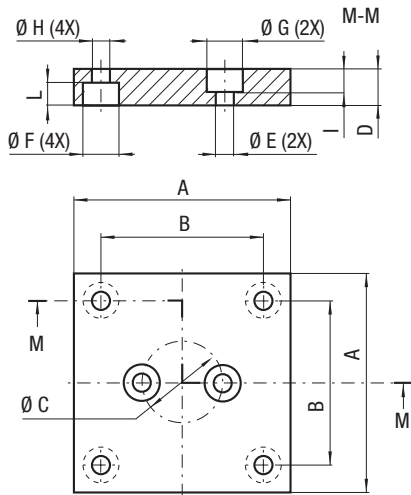

CODE	Reference to standards	A		B		$\varnothing C$		D		$\varnothing E$		$\varnothing F$		$\varnothing G$		$\varnothing H$		I		L	
		mm	inch	mm	inch	mm	inch	mm	inch	mm	inch	mm	inch	mm	inch	mm	inch	mm	inch	mm	inch
FBA 45	20	70	2.76	50	1.97	20	0.79	20	0.79	9	0.35	18	0.71	15	0.59	11	0.43	14	0.55	12	0.47
FBA 50	20	75	2.95	56,5	2.22	20	0.79	20	0.79	9	0.35	18	0.71	15	0.59	11	0.43	14	0.55	12	0.47

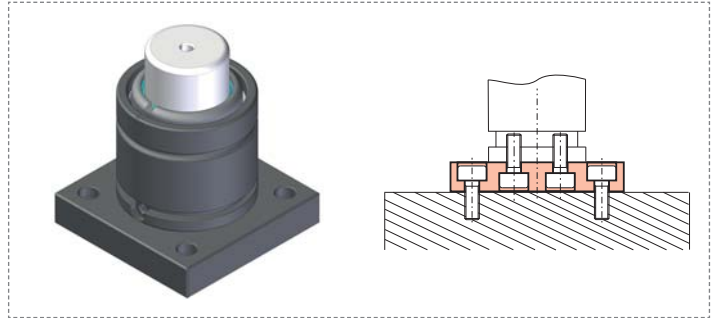
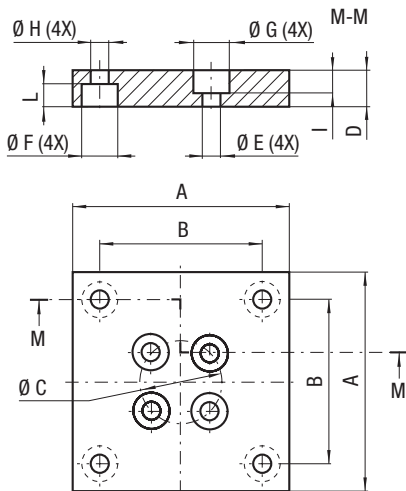

CODE	Reference to standards	A		B		$\varnothing C$		D		$\varnothing E$		$\varnothing F$		$\varnothing G$		$\varnothing H$		I		L	
		mm	inch	mm	inch	mm	inch	mm	inch	mm	inch	mm	inch	mm	inch	mm	inch	mm	inch	mm	inch
FBA 75	20	100	3.94	73,5	2.89	40	1.57	20	0.79	9	0.35	18	0.71	15	0.59	11	0.43	14	0.55	12	0.47
FBA 95	20	120	4.72	92	3.62	60	1.57	20	0.79	9	0.35	20	0.79	15	0.59	13,5	0.53	14	0.55	13	0.51
FBA 120	20	140	5.51	109,5	4.31	80	3.15	20	0.79	11	0.43	20	0.79	18	0.71	13,5	0.53	15	0.59	13	0.51
FBA 150	20	190	7.48	138	5.43	100	3.94	25	0.98	11	0.43	26	1.02	18	0.71	17,5	0.69	15	0.59	17	0.67
FBA 195	20	210	8.27	170	6.69	120	4.72	25	0.98	13,5	0.53	26	1.02	20	0.79	17,5	0.69	15	0.59	17	0.67

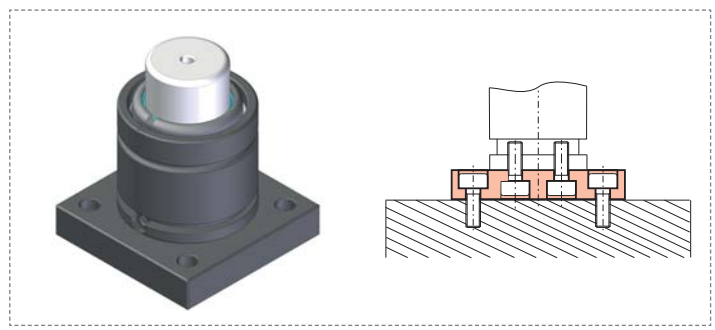
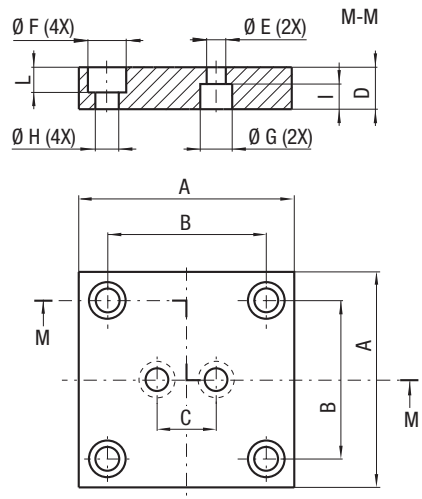

CODE	Reference to standards	A		B		C		D		Ø E		Ø F		Ø G		Ø H		I		L	
		mm	inch	mm	inch	mm	inch	mm	inch	mm	inch	mm	inch	mm	inch	mm	inch	mm	inch	mm	inch
FBB 45	3-14	70	2.76	50	1.97	20	0.79	20	0.79	9	0.35	15	0.59	15	0.59	9	0.35	12	0.47	12	0.47
FBB 50	3-14	75	2.95	56,5	2.22	20	0.79	20	0.79	9	0.35	15	0.59	15	0.59	9	0.35	12	0.47	12	0.47
FBB 63	3-14	100	3.94	73,5	2.89	20	0.79	20	0.79	9	0.35	18	0.71	15	0.59	11	0.43	12	0.47	12	0.47

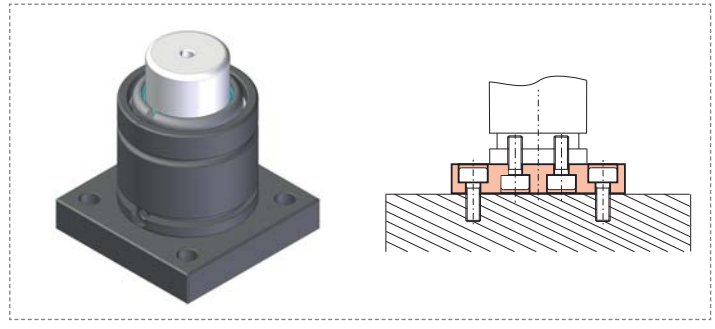
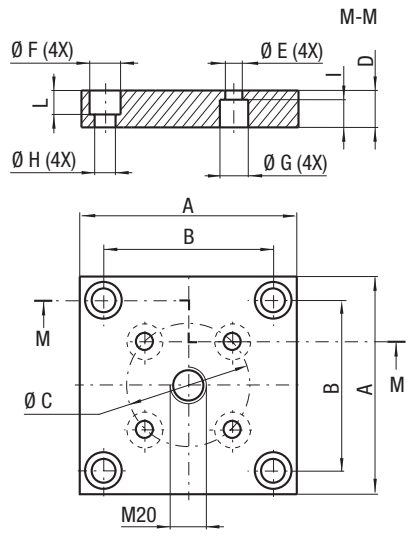

CODE	Reference to standards	A		B		Ø C		D		Ø E		Ø F		Ø G		Ø H		I		L	
		mm	inch	mm	inch	mm	inch	mm	inch	mm	inch	mm	inch	mm	inch	mm	inch	mm	inch	mm	inch
FBB 75	3-14	100	3.94	73,5	2.89	40	1.57	20	0.79	9	0.35	18	0.71	15	0.59	11	0.43	12	0.47	14	0.55
FBB 95	3-14	120	4.72	92	3.62	60	2.36	20	0.79	9	0.35	20	0.79	15	0.59	13,5	0.53	14	0.55	13	0.51
FBB 120	3-14	140	5.51	109,5	4.31	80	3.15	20	0.79	11	0.43	20	0.79	18	0.71	13,5	0.53	15	0.59	13	0.51
FBB 150A	3-14	190	7.48	138	5.43	100	3.94	20	0.79	11	0.43	20	0.79	18	0.71	13,5	0.53	15	0.59	13	0.51
FBB 195	14	210	8.27	170	6.69	120	4.72	25	0.98	13,5	0.53	26	1.02	20	0.98	17,5	0.69	15	0.59	17	0.67

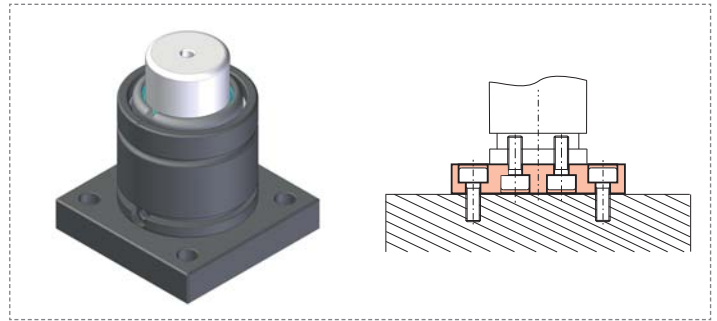
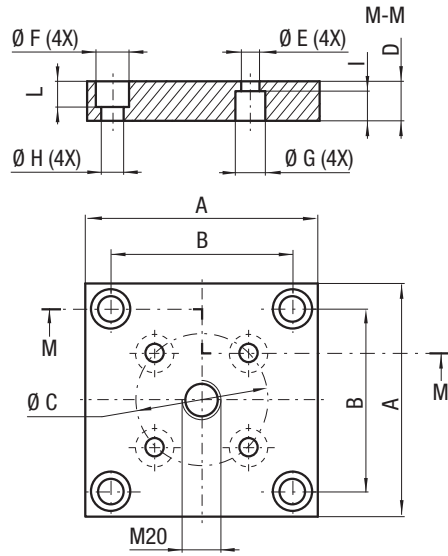

CODE	Reference to standards	A		B		Ø C		D		Ø E		Ø F		Ø G		Ø H		I		L	
		mm	inch	mm	inch	mm	inch	mm	inch	mm	inch	mm	inch	mm	inch	mm	inch	mm	inch	mm	inch
FBC75	0	100	3.94	73,5	2.89	40	1.57	20	0.79	9	0.35	18	0.71	15	0.59	11	0.43	12	0.47	15	0.55

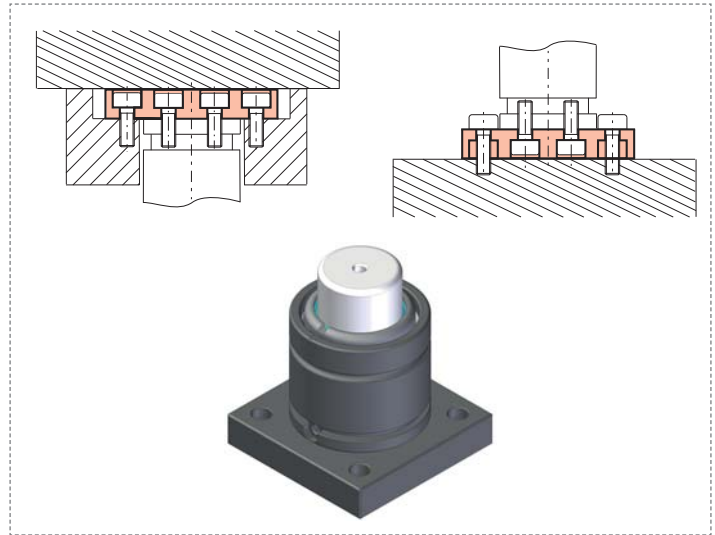
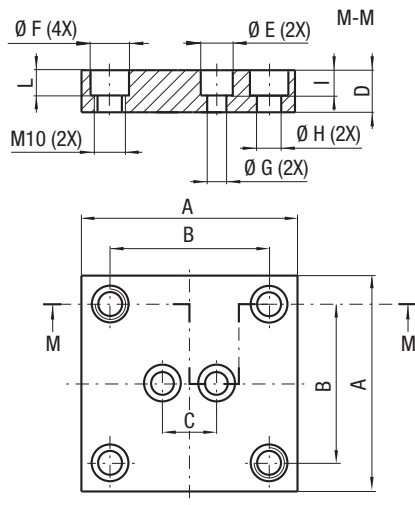

CODE	Reference to standards	A		B		C		D		Ø E		Ø F		Ø G		Ø H		I		L	
		mm	inch	mm	inch	mm	inch	mm	inch	mm	inch	mm	inch	mm	inch	mm	inch	mm	inch	mm	inch
FBD 45	3	70	2.76	50	1.97	20	0.79	20	0.79	15	0.59	15	0.59	9	0.35	9	0.35	12	0.47	12	0.47
FBD 50	3	75	2.95	56,5	2.22	20	0.79	20	0.79	15	0.59	15	0.59	9	0.35	9	0.35	12	0.47	12	0.47

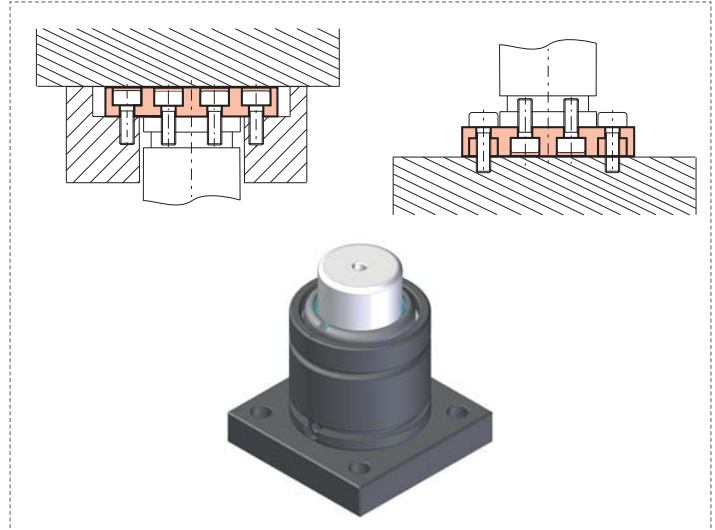
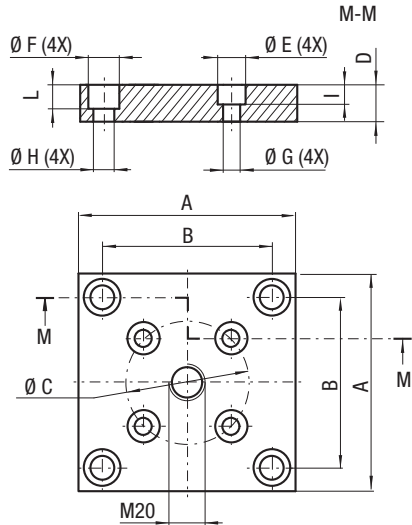

CODE	Reference to standards	A		B		Ø C		D		Ø E		Ø F		Ø G		Ø H		I		L	
		mm	inch	mm	inch	mm	inch	mm	inch	mm	inch	mm	inch	mm	inch	mm	inch	mm	inch	mm	inch
FBD 75	3	100	3.94	73,5	2.89	40	1.57	20	0.79	15	0.59	18	0.71	9	0.35	11	0.43	12	0.47	15	0.59
FBD 150	3-8	190	7.48	138	5.43	100	3.94	20	0.79	18	0.71	26	1.02	11	0.43	17,5	0.69	15	0.59	17	0.67



M-M

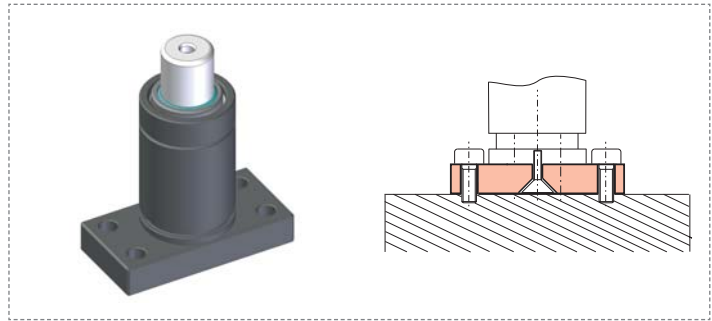
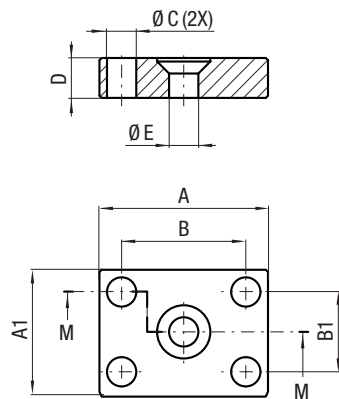

CODE	Reference to standards	A		A1		B		B1		Ø C		D		Ø E	
		mm	inch	mm	inch	mm	inch	mm	inch	mm	inch	mm	inch	mm	inch
FBE 19	0	38	1.50	28	1.10	28	1.10	18	0.71	6,6	0.26	9	0.35	6,6	0.26
FBE 25	0	44	1.73	28	1.10	34	1.34	18	0.71	6,6	0.26	9	0.35	6,6	0.26

M-M

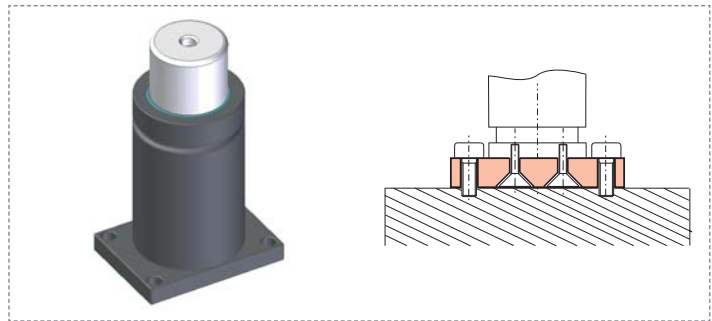
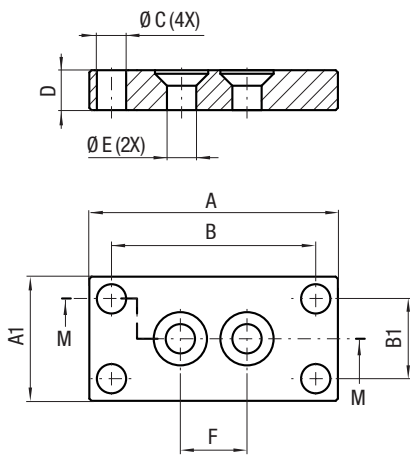

CODE	Reference to standards	A		A1		B		B1		Ø C		D		Ø E		F	
		mm	inch	mm	inch	mm	inch	mm	inch	mm	inch	mm	inch	mm	inch	mm	inch
FBE 32	0	51	2.01	32	1.26	41	1.61	22	0.87	6.6	0.26	9	0.35	6,6	0.26	15	0.59
FBE 38	0	57	2.24	38	1.50	47	1.85	28	1.10	6.6	0.26	9	0.35	6,6	0.26	20	0.79
FBE 50	0	69	2.72	50	1.97	59	2.32	40	1.57	6.6	0.26	9	0.35	9	0.35	20	0.79
FBE 63	0	84	3.31	65	2.56	70	2.76	50	1.97	6.6	0.26	9	0.35	9	0.35	20	0.79

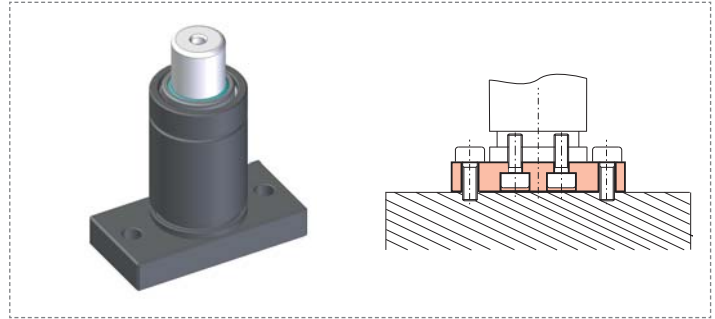
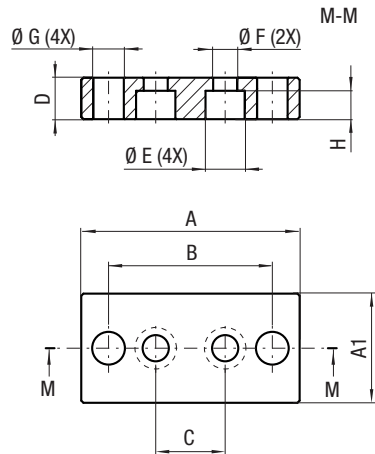

CODE	Reference to standards	A		A1		B		C		D		Ø E		Ø F		Ø G		H	
		mm	inch	mm	inch	mm	inch	mm	inch	mm	inch	mm	inch	mm	inch	mm	inch	mm	inch
FBF 45	0	90	3.54	45	1.77	70	2.76	20	0.79	16	0.63	14	0.55	9	0.35	9	0.35	10	0.39
FBF 50	0	100	3.94	50	1.97	75	2.95	31,8	1.25	19	0.75	18	0.71	11	0.43	14	0.55	13	0.51

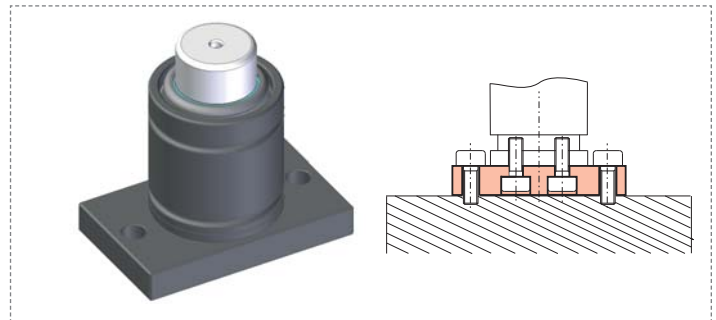
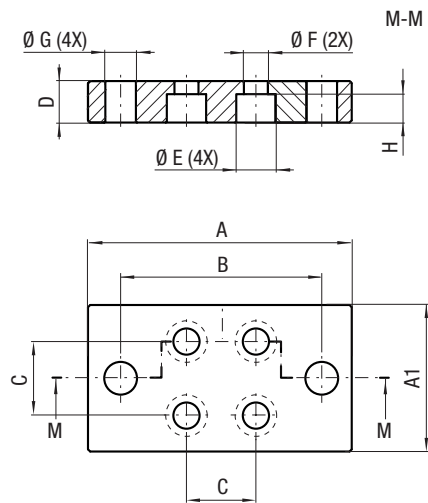

CODE	Reference to standards	A		A1		B		C		D		Ø E		Ø F		Ø G		H	
		mm	inch	mm	inch	mm	inch	mm	inch	mm	inch	mm	inch	mm	inch	mm	inch	mm	inch
FBF 75	0	130	5.12	80	3.15	105	4.13	38,1	1.50	19	0.75	20	0.79	14	0.55	14	0.55	13	0.51



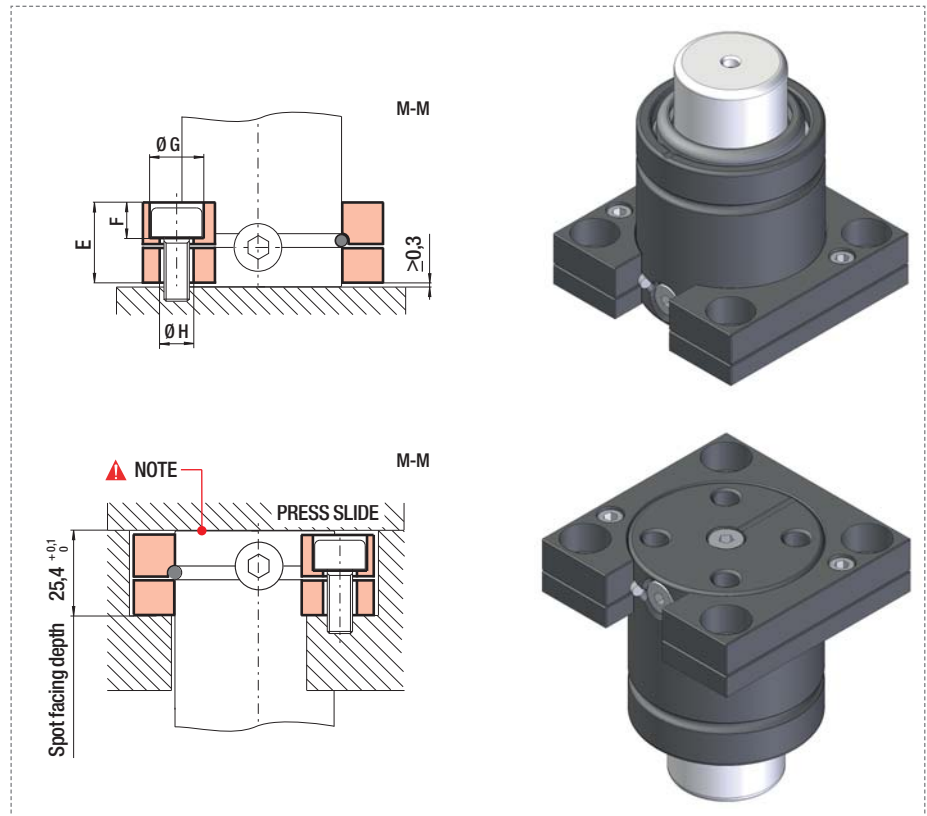
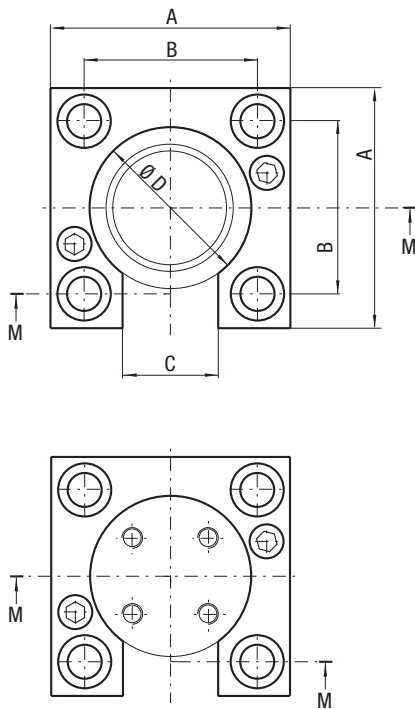

CODE	Reference to standards	A		B		C		Ø D		E		F		Ø G		Ø H	
		mm	inch	mm	inch	mm	inch	mm	inch	mm	inch	mm	inch	mm	inch	mm	inch
FS1 50	0	75	2.95	53,9	2.12	30	1.18	50,5	1.99	25	0.98	11	0.43	17	0.67	11	0.43
FS1 63	0	100	3.94	73,5	2.89	30	1.18	63,5	2.50	25	0.98	11	0.43	17	0.67	11	0.43
FS1 75	0	100	3.94	76,2	3.00	30	1.18	75,5	2.97	25	0.98	13	0.51	20	0.79	13	0.51
FS1 95	0	125	4.92	98,3	3.87	30	1.18	95,5	3.76	25	0.98	13	0.51	20	0.79	13	0.51
FS1 120	0	140	5.51	114,3	4.50	30	1.18	120,5	4.74	25	0.98	13	0.51	20	0.79	13	0.51
FS1 150	0	175	6.89	139,7	5.50	30	1.18	150,5	5.93	25	0.98	17	0.67	25	0.98	17	0.67

! NOTE

- IT** Garantire sempre il contatto tra la press slide e il fondo del cilindro. Massimo gap permesso è 0.1 mm
- EN** Make sure there is always a contact between the bottom cylinder surface and the press slide. Max gap allowed is 0.1mm
- DE** Es muss immer ein Kontakt zwischen der Arbeitsfläche der Presse und dem Boden der Gasdruckfeder gewährleistet sein. Es ist ein maximale Lücke von 0.1mm erlaubt
- FR** Toujours consentir un contact entre la surface du fond du cylindre et la presse. Gap maximum permis est 0.1mm
- ES** Garantizar siempre un contacto entre la base del cilindro y la corredera del troquel. Espacio máximo permitido es de 0.1mm
- PT** Garantir sempre o contacto entre o fundo do cilindro e o dispositivo de pressão. Tolerância máxima permitida de 0,1mm

ISO	VDI	BMW	Ford
General Motors	Mercedes Benz	Volkswagen	

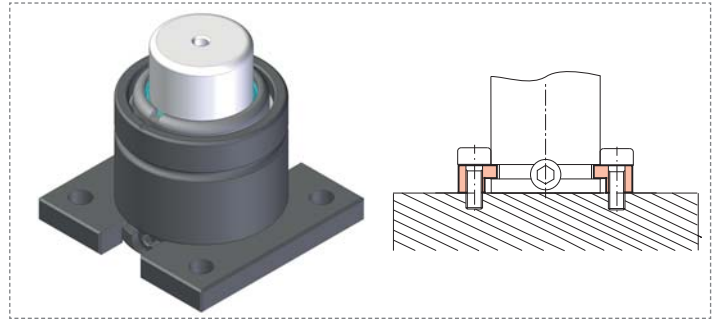
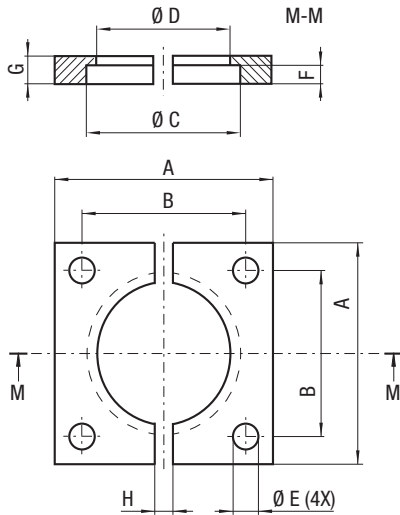

CODE	Reference to standards	A		B		Ø C		Ø D		Ø E		F		G		H	
		mm	inch	mm	inch	mm	inch	mm	inch	mm	inch	mm	inch	mm	inch	mm	inch
FS2 32	1-3-4-7-15	50	1.97	35	1.38	32,5	1.28	28,5	1.12	6,6	0.26	4	0.16	7	0.28	5	0.20
FS2 38	1-3-4-7-15	55	2.17	40	1.57	38,5	1.52	34,5	1.36	7	0.28	4	0.16	7	0.28	5	0.20
FS2 45	1-2-3-4-7-15-21-26	70	2.76	50	1.97	45,5	1.79	41,5	1.63	9	0.35	4	0.16	7	0.28	20	0.79
FS2 50	1-2-3-4-7-15-21-26	75	2.95	56,5	2.22	50,5	1.99	44,5	1.75	9	0.35	8	0.31	12	0.47	24	0.95
FS2 63	0	85	3.35	63,5	2.50	63,5	2.50	57,5	2.26	11	0.43	8	0.31	12	0.47	24	0.95
FS2 75	1-2-3-4-7-15-21-26	100	3.94	73,5	2.89	75,5	2.97	68,5	2.70	11	0.43	8	0.31	12	0.47	24	0.95
FS2 95	1-2-3-4-7-15-21-26	120	4.72	92	3.62	95,5	3.76	88,5	3.48	13,5	0.53	8	0.31	12	0.47	24	0.95
FS2 120	1-2-3-4-7-15-21-26	140	5.51	109,5	4.31	120,5	4.74	113,5	4.47	13,5	0.53	8	0.31	12	0.47	24	0.95
FS2 150	1-2-3-4-7-15-21-26	190	7.48	138	5.43	150,5	5.93	143,5	5.65	17,5	0.69	8	0.31	12	0.47	24	0.95
FS2 195	1-2-4-7-15-21-26	210	8.27	170	6.69	195,5	7.70	188	7.40	17,5	0.69	8	0.31	13	0.51	24	0.95

VDI	BMW	Ford	Mercedes Benz
Volkswagen			

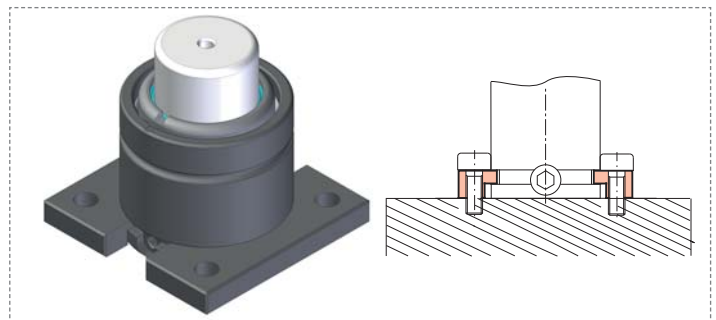
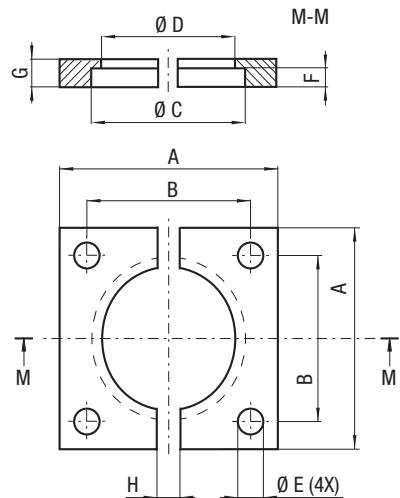

CODE	Reference to standards	A		B		Ø C		Ø D		Ø E		F		G		H	
		mm	inch	mm	inch	mm	inch	mm	inch	mm	inch	mm	inch	mm	inch	mm	inch
FS2B 32	2-21-26	50	1.97	35	1.38	32,5	1.28	28,5	1.12	6,6	0.26	4	0.16	7	0.28	12	0.47
FS2B 38	2-21-26	55	2.17	40	1.57	38,5	1.52	34,5	1.36	6,6	0.26	4	0.16	7	0.28	12	0.47
FS2B 63	2-3-4-15-21	100	3.94	73,5	2.89	64	2.52	57,5	2.60	11	0.43	8	0.32	12	0.47	24	0.95

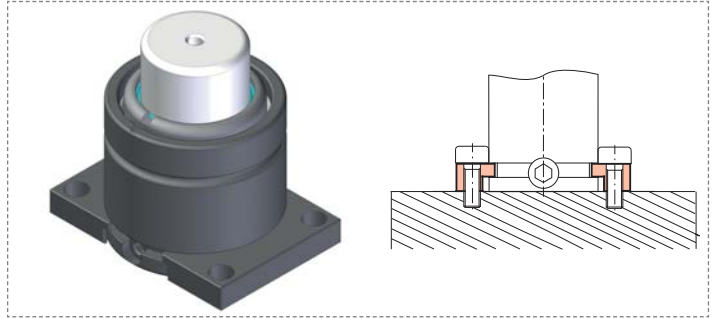
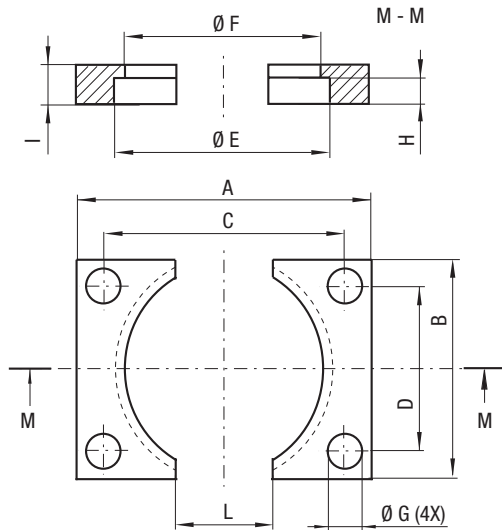

CODE	Reference to standards	A		B		C		D		Ø E		Ø F		Ø G		H		I		L	
		mm	inch	mm	inch	mm	inch	mm	inch	mm	inch	mm	inch	mm	inch	mm	inch	mm	inch	mm	inch
FS2A 32	0	50	1.97	27	1.06	40	1.57	18	0.71	32,5	1.28	28,5	1.12	6,6	0.26	4	0.16	7	0.28	20	0.79
FS2A 38	0	55	2.17	33	1.30	44	1.73	20	0.79	38,5	1.52	34,5	1.36	6,6	0.26	4	0.16	7	0.28	20	0.79
FS2A 45	0	70	2.76	40	1.57	57	2.24	27	1.06	45,5	1.79	41,5	1.63	9	0.35	4	0.16	7	0.28	25	0.98
FS2A 50	0	75	2.95	45	1.77	62	2.44	32	1.26	50,5	1.99	44,5	1.75	9	0.35	8	0.31	12	0.47	25	0.98
FS2A 63	0	85	3.35	58	2.28	69	2.72	42	1.65	63,5	2.5	57,5	2.26	11	0.43	8	0.31	12	0.47	30	1.18
FS2A 75	0	100	3.94	70	2.76	84	3.31	54	2.13	75,5	2.97	68,5	2.7	11	0.43	8	0.31	12	0.47	30	1.18
FS2A 95	0	120	4.72	90	3.54	100	3.94	70	2.76	95,5	3.76	88,5	3.48	13,5	0.53	8	0.31	12	0.47	40	1.57
FS2A 120	0	140	5.51	115	4.53	120	4.72	95	3.74	120,5	4.74	113,5	4.47	13,5	0.53	8	0.31	12	0.47	50	1.97
FS2A 150	0	190	7.48	145	5.71	165	6.5	120	4.72	150,5	5.93	143,5	5.65	17,5	0.69	8	0.31	12	0.47	60	2.36
FS2A 195	0	210	8.27	190	7.48	185	7.28	165	6.50	195,5	7.70	188	7.40	17,5	0.69	8	0.31	13	0.51	80	3.15

FS2C

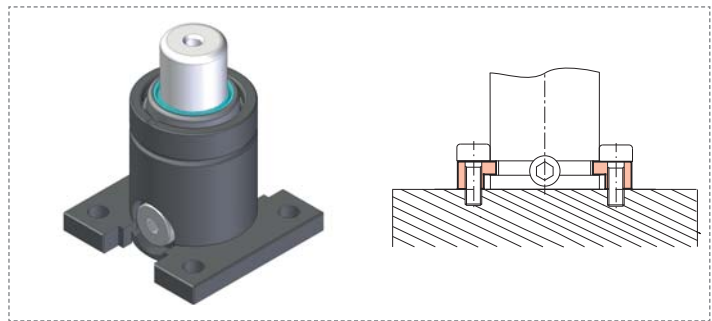
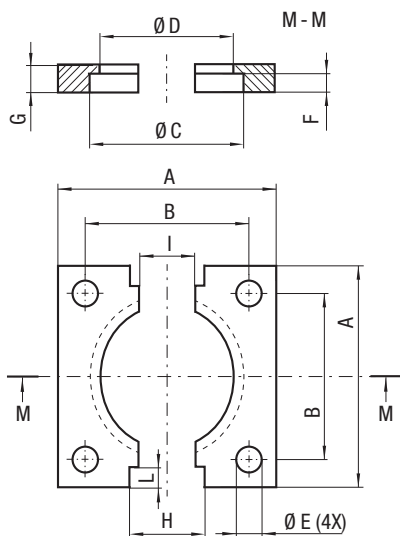

CODE	Reference to standards	A		B		C		D		Ø E		F		G		H		I		L	
		mm	inch	mm	inch	mm	inch	mm	inch	mm	inch	mm	inch	mm	inch	mm	inch	mm	inch	mm	inch
FS2C 32	0	50	1.97	35	1.38	32,5	1.28	28,5	1.12	6,6	0.26	4	0.16	7	0.28	21	0.83	17	0.67	6,5	0.26
FS2C 38	0	55	2.17	40	1.57	38,5	1.52	34,5	1.36	6,6	0.26	4	0.16	7	0.28	21	0.83	17	0.67	6,5	0.26

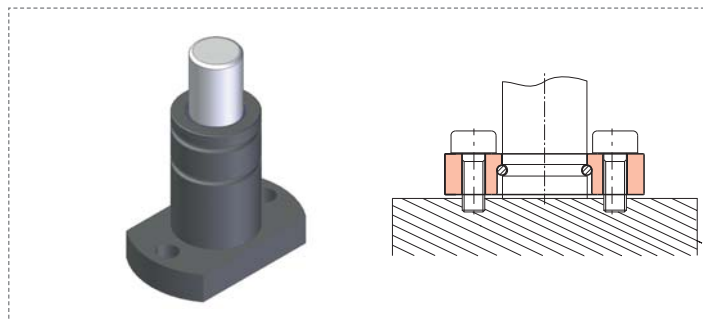
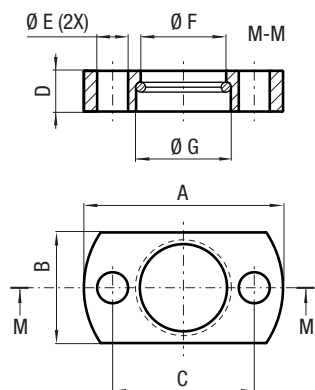

CODE	Reference to standards	A		B		C		D		Ø E		Ø F		Ø G	
		mm	inch	mm	inch	mm	inch	mm	inch	mm	inch	mm	inch	mm	inch
FS3 19	0	45	1.77	25	0.98	32	1.26	9,2	0.36	7	0.28	19,3	0.76	21,4	0.84
FS3 25	0	50	1.97	30	1.18	38	1.50	9,2	0.36	7	0.28	25,3	1.00	27,4	1.08

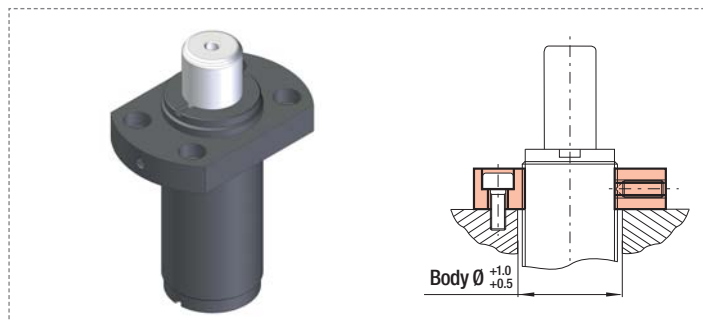
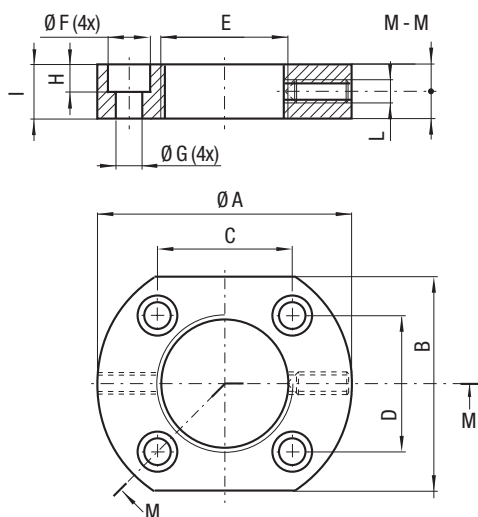

CODE	Reference to standards	Ø A		B		C		D		E	Ø F		Ø G		H		I		L
		mm	inch	mm	inch	mm	inch	mm	inch		mm	inch	mm	inch	mm	inch	mm	inch	
FCA 38	0	75	2.95	50	1.97	50,3	1.98	29	1.14	M 38 x 1,5	14	0.55	9	0.35	8	0.31	12	0.47	M6
FCA 45	0	90	3.54	60	2.36	60	2.36	34	1.34	M 45 x 1,5	14	0.55	9	0.35	8	0.31	16	0.63	M6
FCA 50	0-22	100	3.94	66	2.60	66	2.60	38	1.50	M 50 x 1,5	14	0.55	9	0.35	8	0.31	16	0.63	M6



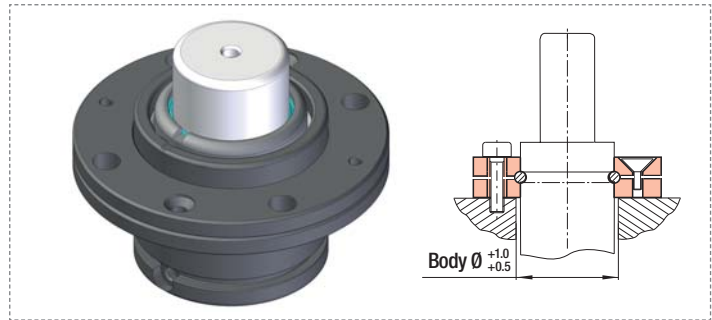
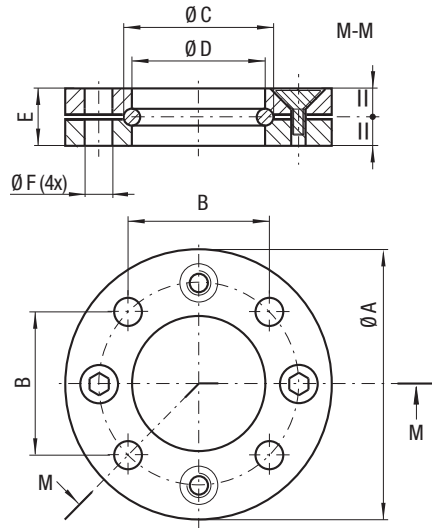

For **KE** series only

CODE	Reference to standards	Ø A		B		Ø C		Ø D		E		Ø F	
		mm	inch	mm	inch	mm	inch	mm	inch	mm	inch	mm	inch
FCB 50	0	95	3.74	56,5	2.22	52	2.05	50,5	1.99	13	0.51	9	0.35
FCB 63	0	122	4.80	73,5	2.89	66	2.60	63,5	2.50	16	0.63	11	0.43
FCB 75	0	122	4.80	73,5	2.89	78	3.07	75,5	2.97	16	0.63	11	0.43
FCB 95	0	150	5.91	92	3.62	98	3.86	95,5	3.76	18	0.71	13,5	0.53

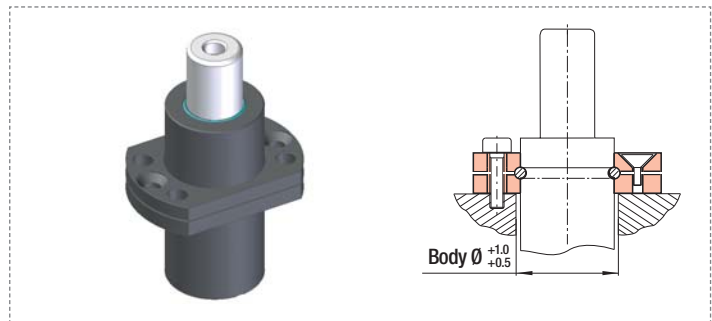
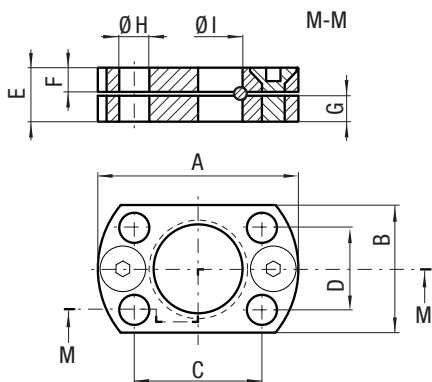

CODE	Reference to standards	A		B		C		D		E		F		G		Ø H		Ø I	
		mm	inch	mm	inch	mm	inch	mm	inch	mm	inch	mm	inch	mm	inch	mm	inch	mm	inch
FCD 19	0	44	1.73	28	1.10	28	1.10	18	0.71	11	0.43	5,2	0.20	5,6	0.22	6,6	0.26	19,5	0.77
FCD 25	0	50	1.97	30	1.18	34	1.34	18	0.71	11	0.43	5,2	0.20	5,6	0.22	6,6	0.26	25,5	1.00
FCD 32	0	57	2.24	39	1.54	40	1.57	22	0.87	11	0.43	5,2	0.20	5,6	0.22	6,6	0.26	32,5	1.28
FCD 38	0	63	2.48	46	1.81	45	1.77	26	1.02	11	0.43	5,2	0.20	5,6	0.22	6,6	0.26	38,5	1.52
FCD 50	0	75	2.95	58	2.28	54	2.13	34	1.34	11	0.43	6,2	0.24	4,6	0.18	6,6	0.26	50,5	1.99
FCD 63	0	98	3.86	76	2.99	74	2.91	40	1.57	13	0.51	8,9	0.35	3,9	0.15	9	0.35	63,5	2.50

ISO General Motors	VDI Mercedes Benz	BMW Peugeot - Citroën	Ford Volkswagen
-----------------------	----------------------	--------------------------	--------------------

(ISO)

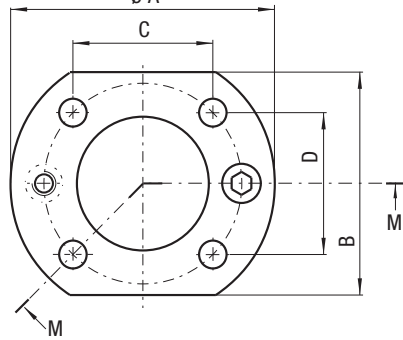
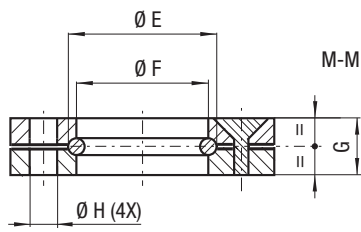

(VDI)

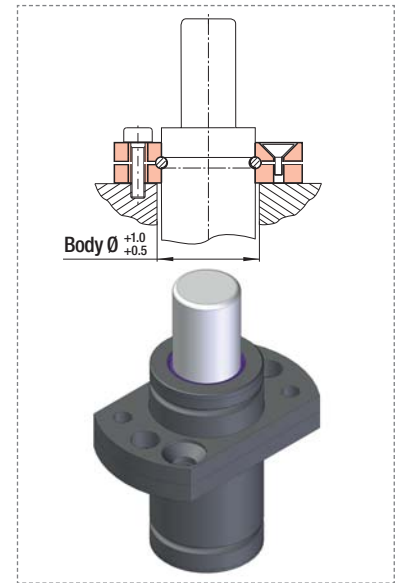
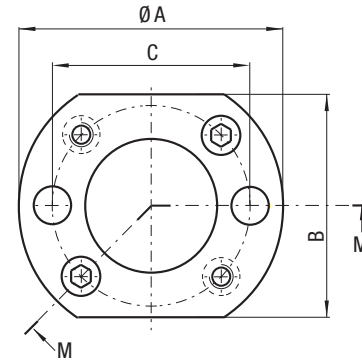
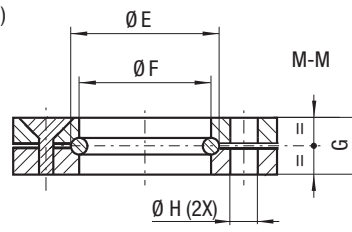

CODE	Reference to standards	Ø A		B		C		D		Ø E		Ø F		G		Ø H	
		mm	inch	mm	inch	mm	inch	mm	inch	mm	inch	mm	inch	mm	inch	mm	inch
FC 12 A	VDI 0	34	1.34	21	0.83	24	0.94	-	-	13,7	0.54	12,5	0.49	9	0.35	6,6	0.26
FC 15 A	VDI 0	37	1.36	24	0.94	27	1.06	-	-	16,7	0.66	15,5	0.61	9	0.35	6,6	0.26
FC 19 B	ISO 1-5-19	44	1.73	25	0.98	30	1.18	12	0.47	21,9	0.86	19,5	0.77	9	0.35	6,6	0.26
FC 25 B	ISO 1-5-19	50	1.97	30	1.18	34	1.34	18	0.71	27,9	1.10	25,5	1.00	9	0.35	6,6	0.26
FCC 19 A	VDI 2-3-17-21-23	44	1.73	25	0.98	32	1.26	-	-	21	0.83	19,5	0.77	9	0.35	6,6	0.26
FCC 25 A	VDI 2-3-17-19-21-23	50	1.97	30	1.18	38	1.50	-	-	27	1.06	25,5	1.00	9	0.35	6,6	0.26

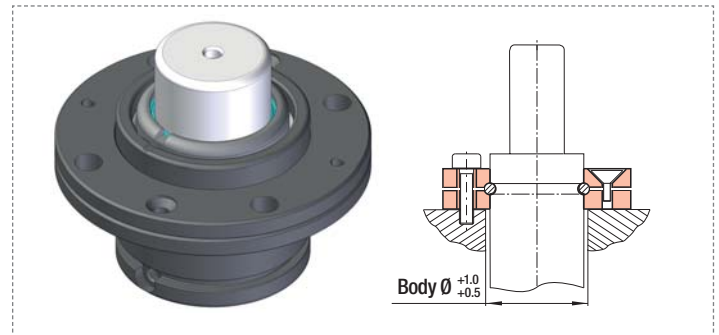
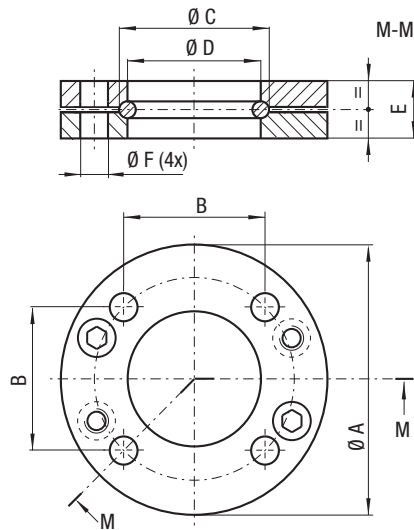

CODE	Reference to standards	Ø A		B		Ø C		Ø D		E		Ø F	
		mm	inch	mm	inch	mm	inch	mm	inch	mm	inch	mm	inch
FC 32A	1-2-3-9-16-24	60	2.36	35	1.38	34	1.34	32,5	1.28	9	0.35	7	0.28
FC 38A	1-2-3-9-16-24	68	2.68	40	1.57	40	1.57	38,5	1.52	9	0.35	7	0.28
FC 45A	1-2-3-9-16-24	86	3.39	50	1.97	47	1.85	45,5	1.79	13	0.51	9	0.35
FC 50A	1-2-3-9-16-24	95	3.74	56,5	2.22	54	2.13	50,5	1.99	13	0.51	9	0.35
FC 63A	0	122	4.80	73,5	2.89	67	2.64	63,5	2.50	16	0.63	11	0.43
FC 75A	1-2-3-9-16-24	122	4.80	73,5	2.89	80	3.15	75,5	2.97	16	0.63	11	0.43
FC 95A	1-2-3-9-16-24	150	5.91	92	3.62	100	3.94	95,5	3.76	18	0.71	13,5	0.53
FC 120A	1-2-3-9-16-24	175	6.89	109,5	4.31	125	4.92	120,5	4.74	21	0.83	13,5	0.53
FC 150A	1-2-3-9-16-24	220	8.66	138	5.43	155	6.10	150,5	5.93	27	1.06	17,5	0.69
FC 195A	1-2-9-16-24	290	11.42	170	6.69	200	7.87	195,5	7.70	27	1.06	17,5	0.69

FCQ - FCQC

ISO	VDI	BMW	Ford
General Motors	Volkswagen		

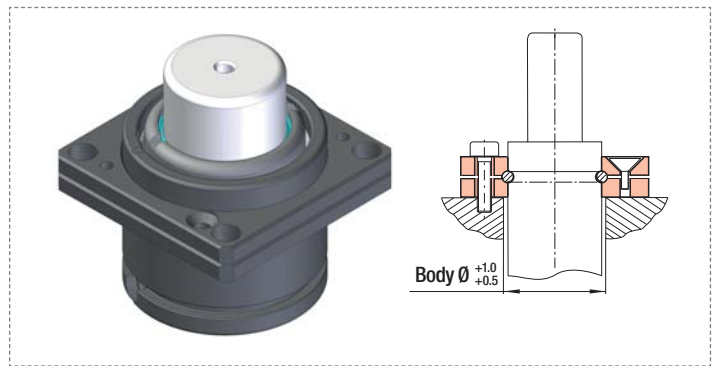
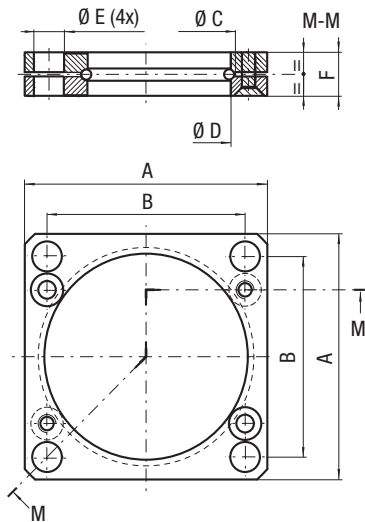

CODE		Reference to standards	A		B		Ø C		Ø D		Ø E		F	
PHASING OUT	NEW		mm	inch	mm	inch	mm	inch	mm	inch	mm	inch	mm	inch
FCQ 32 A	FCQC 32	2-4-8-25	45	1.77	35	1.38	34	1.34	32,5	1.28	7	0.28	9	0.26
FCQ 38 A	FCQC 38	1-2-3-4-8-25	52	2.05	40	1.57	40	1.57	38,5	1.52	7	0.28	9	0.35
FCQ 45 A	FCQC 45	1-2-3-4-8-25	64	2.52	50	1.97	47	1.85	45,5	1.79	9	0.35	13	0.51
FCQ 50 A	FCQC 50	1-2-3-4-8-25	70	2.76	56,5	2.22	54	2.13	50,5	1.99	9	0.35	13	0.51
FCQ 63 A	FCQC 63 A	2-3-25	90	3.54	73,5	2.89	67	2.64	63,45	2.50	11	0.43	16	0.63
FCQC 63	FCQC 63	2-4-21	80	3.15	64	2.52	67	2.64	63,45	2.50	11	0.43	16	0.63
FCQ 75 A	FCQC 75	1-2-3-4-8-25	90	3.54	73,5	2.89	80	3.15	75,5	2.97	11	0.43	16	0.63
FCQ 95 A	FCQC 95	1-2-3-4-8-25	110	4.33	92	3.62	100	3.94	95,5	3.76	13,5	0.53	18	0.71
FCQ 120 A	FCQC 120	1-2-3-4-8-25	130	5.12	109,5	4.31	125	4.92	120,5	4.74	13,5	0.53	21	0.83
FCQ 150 A	FCQC 150	1-2-3-4-8-25	162	6.38	138	5.43	155	6.10	150,5	5.93	17,5	0.69	27	1.06
FCQ 195 A	FCQC 195	1-2-4-8-25	210	8.27	170	6.69	200	7.87	195,5	7.70	17,5	0.69	27	1.06

FCQB - FCQD

For KE series only

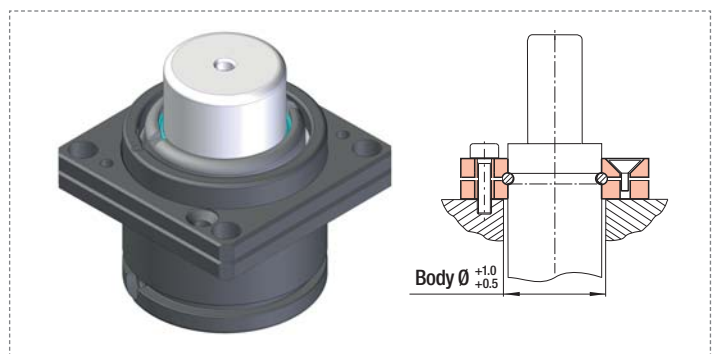
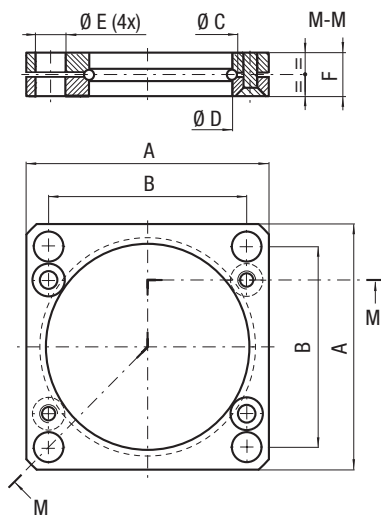

CODE	Reference to standards	A		B		Ø C		Ø D		Ø E		F	
		mm	inch	mm	inch	mm	inch	mm	inch	mm	inch	mm	inch
FCQB 50	0	70	2.76	56,5	2.22	52	2.05	50,5	1.99	9	0.35	13	0.51
FCQB 63	0	90	3.54	73,5	2.89	66	2.60	63,5	2.50	11	0.43	16	0.63
FCQD 63	0	80	3.15	64	2.52	66	2.60	63,5	2.50	11	0.43	16	0.63
FCQB 75	0	90	3.54	73,5	2.89	78	3.07	75,5	2.97	11	0.43	16	0.63
FCQB 95	0	110	4.33	92	3.62	98	3.86	95,5	3.76	13,5	0.53	18	0.71

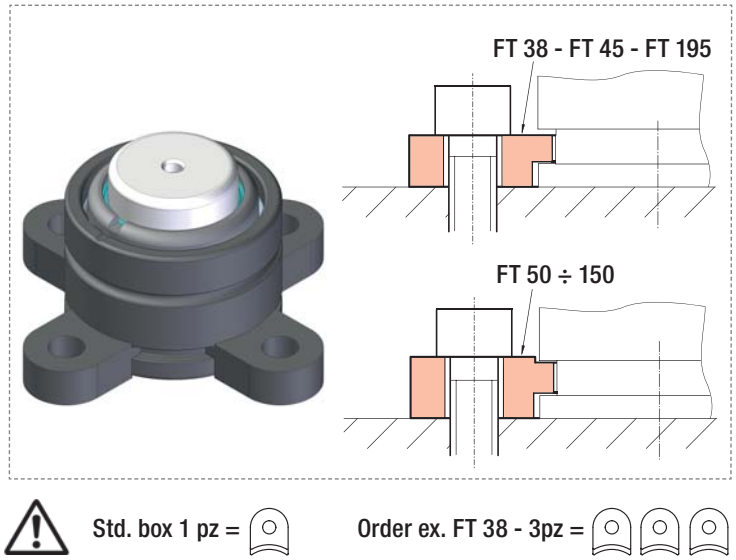
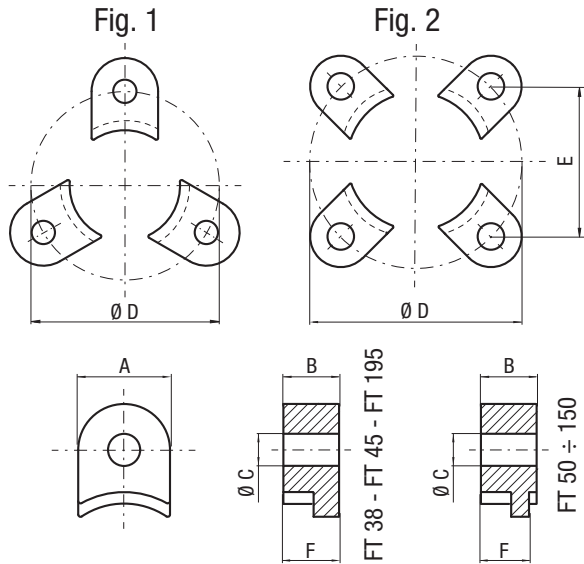

CODE	Reference to standards	A		B		C		Ø D		E		F		Rif. Fig
		mm	inch	mm	inch	mm	inch	mm	inch	mm	inch	mm	inch	
FT 38	0	20	0.79	7	0.28	7	0.28	56,6	2.23	-	-	7	0.28	Fig. 1
FT 45	0	25	0.98	7	0.28	9	0.35	70,7	2.78	-	-	7	0.28	
FT 50	0	30	1.18	14,2	0.56	13	0.51	80	3.15	-	-	13	0.51	
FT 63	0	30	1.18	14,2	0.56	13	0.51	92	3.62	65	2.56	13	0.51	Fig. 2
FT 75	0	30	1.18	14,2	0.56	13	0.51	104	4.09	73,5	2.89	13	0.51	
FT 95	0	40	1.57	14,2	0.56	17	0.67	130	5.12	92	3.62	13	0.51	
FT 120	0	50	1.97	14,2	0.56	17	0.67	155	6.1	109,5	4.31	13	0.51	
FT 150	0	50	1.97	14,2	0.56	21	0.83	195	7.68	138	5.43	13	0.51	
FT 195	0	58	2.28	16	0.63	21	0.83	240	9.45	169	6.65	16	0.63	

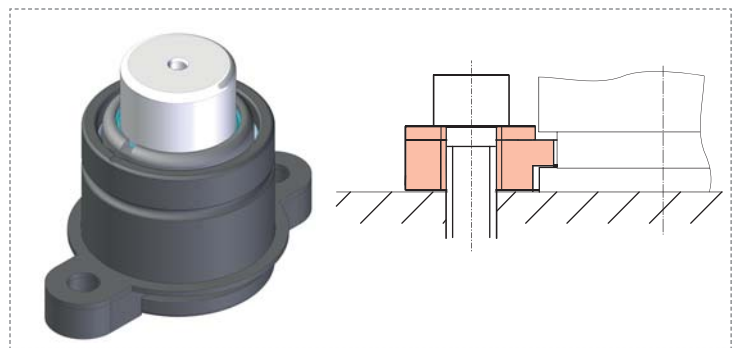
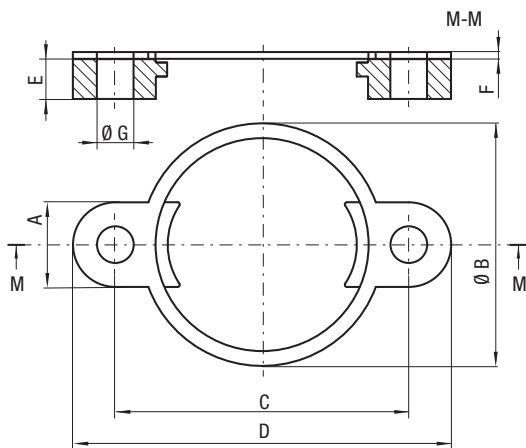

CODE	Reference to standards	A		Ø B		C		D		E		F		Ø G	
		mm	inch	mm	inch	mm	inch	mm	inch	mm	inch	mm	inch	mm	inch
FTP 38	0	20	0.79	48	1.89	56.6	2.23	76.6	3.02	7	0.28	2,5	0.10	7	0.28
FTP 45	0	25	0.98	56	2.20	70.7	2.78	95.7	3.77	7	0.28	2,5	0.10	9	0.35
FTP 50	0	30	1.18	61	2.40	80	3.15	110	4.33	14,2	0.56	2,5	0.10	13	0.51
FTP 63	0	30	1.18	73	2.87	92	3.62	122	4.80	14,2	0.56	2,5	0.10	13	0.51
FTP 75	0	30	1.18	86	3.39	104	4.09	134	5.28	14,2	0.56	2,5	0.10	13	0.51
FTP 95	0	40	1.57	106	4.17	130	5.12	170	6.69	14,2	0.56	2,5	0.10	17	0.67
FTP 120	0	50	1.97	131	5.16	155	6.10	205	8.07	14,2	0.56	2,5	0.10	17	0.67
FTP 150	0	50	1.97	170	6.69	195	7.68	245	9.65	14,2	0.56	2,5	0.10	21	0.83

ISO	VDI	BMW	General Motors
-----	-----	-----	----------------

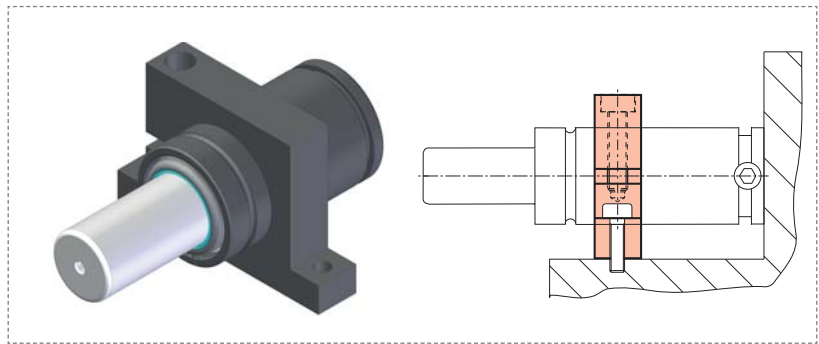
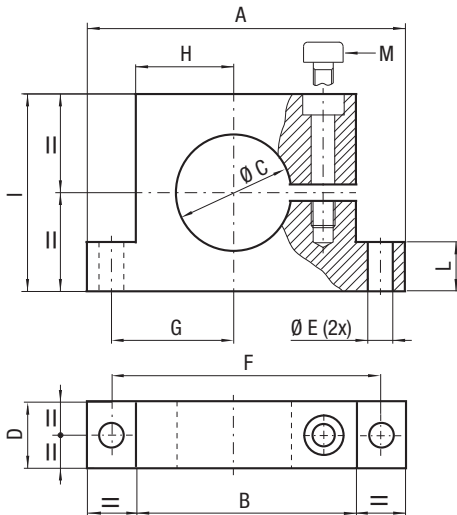

CODE	Reference to standards	A		B		ØC		D		ØE		F		G		H		I		L		M
		mm	inch	mm	inch	mm	inch	mm	inch	mm	inch	mm	inch	mm	inch	mm	inch	mm	inch	mm	inch	
FSA 32	1-2-3-13-19	90	3.54	54	2.13	32	1.26	20	0.79	9	0.35	72	2.83	31	1.22	22	0.87	45	1.77	15	0.59	M8
FSA 38	1-2-3-13-19	95	3.74	59	2.32	38	1.50	20	0.79	9	0.35	77	3.03	34	1.34	25	0.98	55	2.17	15	0.59	M8
FSA 45	1-2-3-13-19	100	3.94	64	2.52	45	1.77	20	0.79	9	0.35	82	3.23	37	1.46	28	1.10	60	2.36	15	0.59	M8
FSA 50	1-2-3-13-19	130	5.12	90	3.54	50	1.97	30	1.18	9	0.35	110	4.33	50	1.97	40	1.57	80	3.15	20	0.79	M8
FSA 75	1-2-3-13-19	160	6.30	115	4.53	75	2.95	30	1.18	11	0.43	137	5.39	63,5	2.50	52,5	2.07	105	4.13	20	0.79	M10
FSA 95	1-2-3-13-19	195	7.68	145	5.71	95	3.74	30	1.18	13,5	0.53	170	6.69	80	3.15	67,5	2.66	125	4.92	20	0.79	M12
FSA 120	1-2-3-13-19	220	8.66	165	6.50	120	4.72	30	1.18	13,5	0.53	195	7.68	92,5	3.64	77,5	3.05	148	5.83	20	0.79	M12
FSA 150	1-2-3-13-19	260	10.24	200	7.87	150	5.91	30	1.18	13,5	0.53	230	9.06	110	4.33	95	3.74	200	7.87	20	0.79	M12

FSB - FSC - FSD

VDI	BMW	Ford	Mercedes Benz
-----	-----	------	---------------

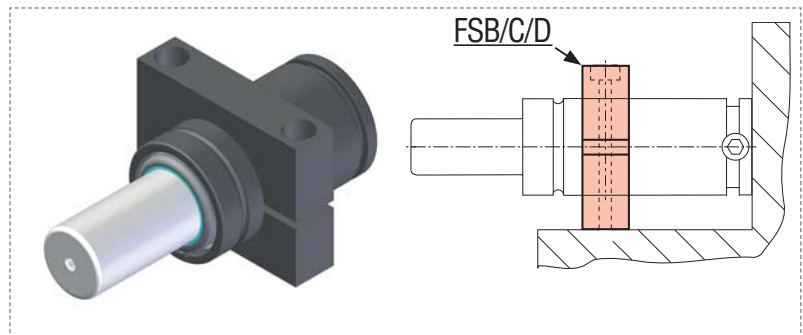
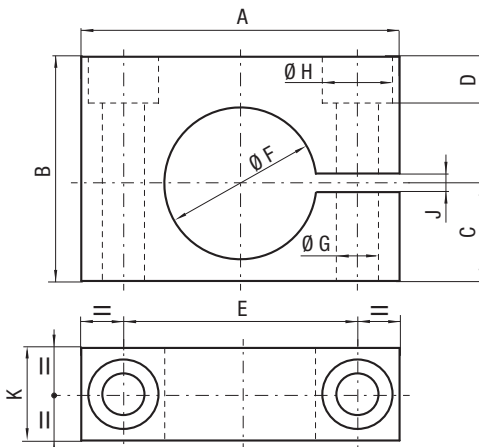

CODE	Reference to standards	A		B		C		D		E		ØF		ØG		ØH		J		K	
		mm	inch	mm	inch	mm	inch	mm	inch	mm	inch	mm	inch	mm	inch	mm	inch	mm	inch	mm	inch
FSB 32	6	80	3.15	63	2.48	38,5	1.52	18	0.71	56	2.20	32	1.26	10,5	0.41	17	0.67	6	0.24	25	0.98
FSD 32	2-3-12-18-21-27	68	2.68	48	1.89	20,9	0.82	10	0.39	50	1.97	32,5	1.28	9	0.35	15	0.59	4	0.16	20	0.79
FSD 38	2-3-12-18-21-27	74	2.91	54	2.13	23,9	0.94	16	0.63	54	2.13	38,5	1.52	9	0.35	15	0.59	4	0.16	20	0.79
FSD 45	2-3-12-18-21-27	80	3.15	60	2.36	27,5	1.08	22	0.87	60	2.36	45,5	1.79	9	0.35	15	0.59	4	0.16	20	0.79
FSD 50	2-3-4-12-18-21-27	90	3.54	70	2.76	30	1.18	25	0.98	68	2.68	50,5	1.99	11	0.43	18	0.71	5	0.20	30	1.18
FSC 63	0	105	4.13	80	3.15	40	1.57	11	0.43	80	3.15	63	2.48	10,5	0.41	17	0.67	10	0.39	30	1.18
FSD 63	2-18-21-27	108	4.25	82	3.23	36,5	1.44	27	1.06	84	3.31	63,5	2.50	11	0.43	18	0.71	5	0.20	30	1.18
FSD 75	2-3-4-12-18-21-27	125	4.92	94	3.70	42	1.65	32	1.26	100	3.94	75,5	2.97	13,5	0.53	20	0.79	5	0.20	30	1.18
FSD 95	2-3-4-12-18-21-27	140	5.51	115	4.53	52,5	2.07	33	1.30	115	4.53	95,5	3.76	13,5	0.53	20	0.79	5	0.20	30	1.18
FSD 120	2-3-12-18-21-27	170	6.69	140	5.51	65	2.56	58	2.28	145	5.71	120,5	4.74	13,5	0.53	20	0.79	7	0.28	30	1.18
FSD 150	2-3-12-18-21-27	200	7.87	170	6.69	80	3.15	68	2.68	175	6.89	150,5	5.93	13,5	0.53	20	0.79	7	0.28	30	1.18

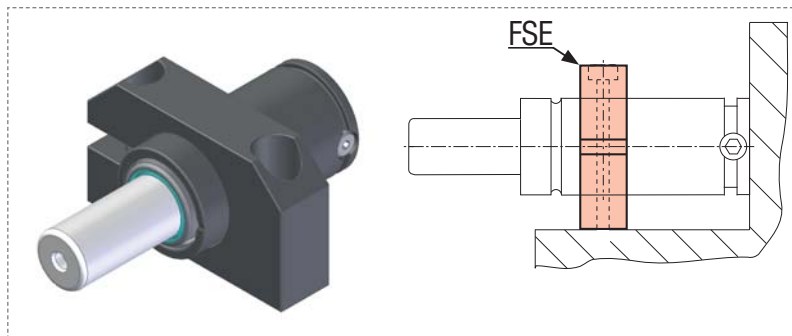
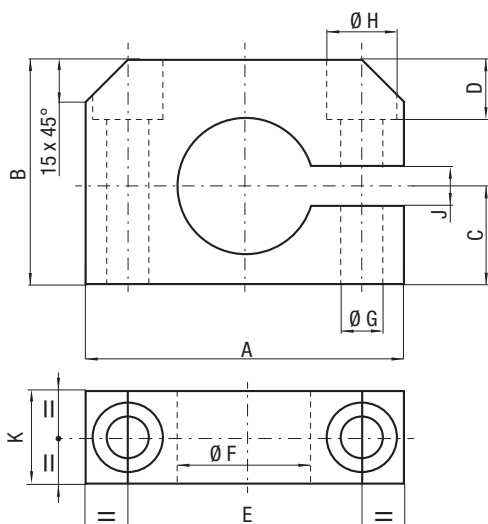

CODE	Reference to standards	A		B		C		D		E		Ø F		Ø G		Ø H		J		K	
		mm	inch	mm	inch	mm	inch	mm	inch	mm	inch	mm	inch	mm	inch	mm	inch	mm	inch	mm	inch
FSE45	0	100	3.94	60	2.36	30	1.18	20	0.79	70	2.76	45,3	1.78	11	0.43	18	0.71	10	0.39	25	0.98

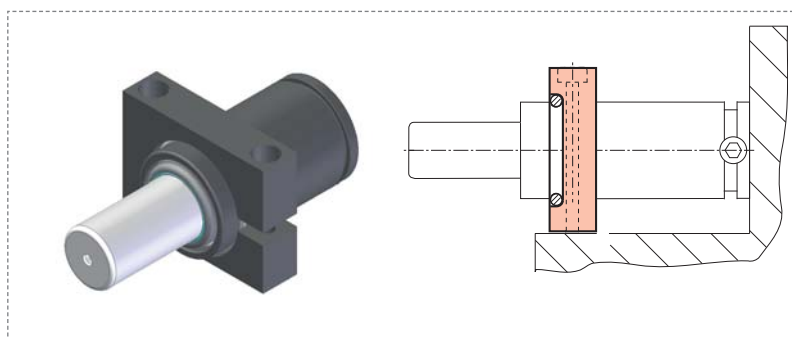
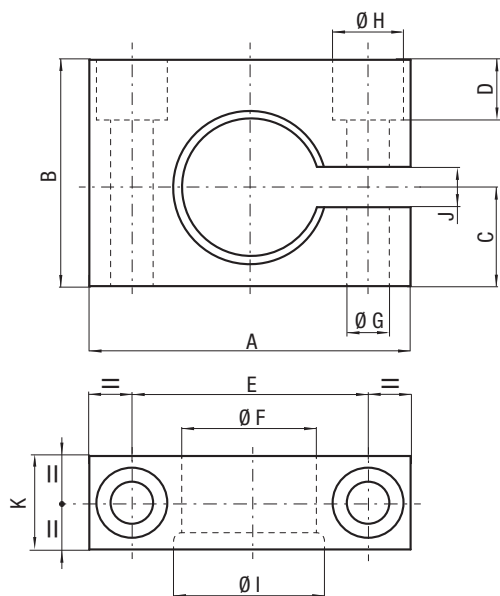

CODE	Reference to standards	A		B		C		D		E		Ø F		Ø G		Ø H		Ø I		J		K	
		mm	inch	mm	inch	mm	inch	mm	inch	mm	inch	mm	inch	mm	inch	mm	inch	mm	inch	mm	inch	mm	inch
FSE50	11	90	3.54	70	2.76	30	1.18	25	0.98	68	2.68	50,3	1.98	11	0.43	18	0.71	54,1	2.13	10	0.39	30	1.18
FSE75	11	125	4.92	94	3.70	42	1.65	19	0.75	100	3.94	75,3	2.96	13	0.51	20	0.79	80,1	3.15	10	0.39	30	1.18
FSE95	11	140	5.51	115	4.53	52,5	2.07	40	1.57	115	4.53	95,3	3.75	13	0.51	20	0.79	100,1	3.94	10	0.39	30	1.18

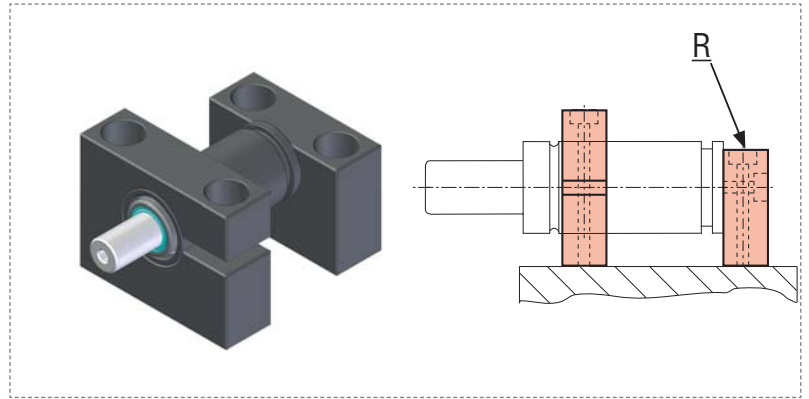
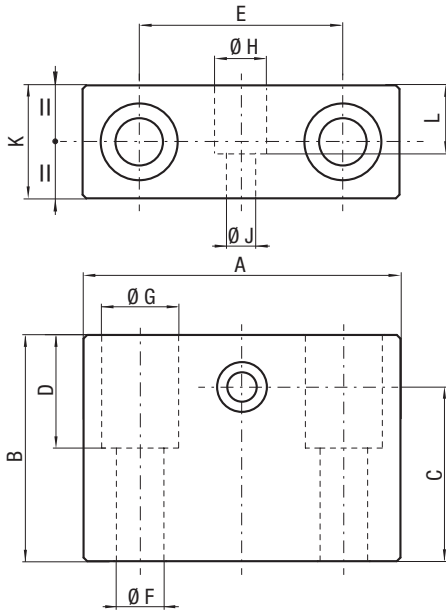

CODE	Reference to standards	A		B		C		D		E		Ø F		Ø G		Ø H		Ø J		L		K	
		mm	inch	mm	inch	mm	inch	mm	inch	mm	inch	mm	inch	mm	inch	mm	inch	mm	inch	mm	inch	mm	inch
R32A	5	70	2.76	50	1.97	38,5	1.52	25	0.98	45	1.77	10,5	0.41	17	0.67	11	0.43	6,5	0.26	15	0.59	25	0.98

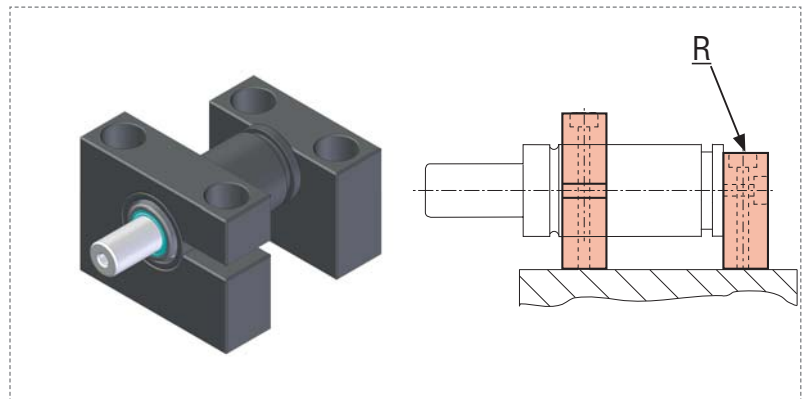
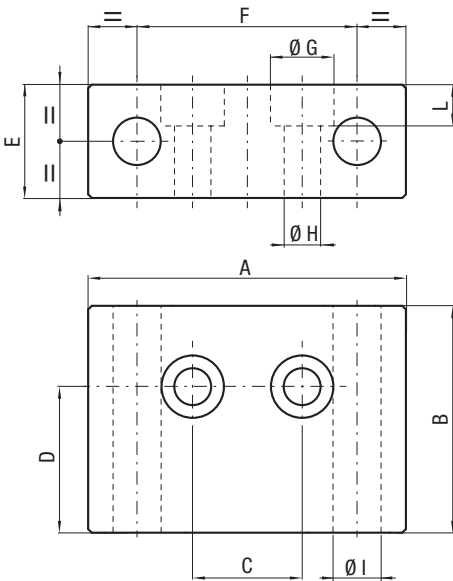

CODE	Reference to standards	A		B		C		D		E		F		Ø G		Ø H		L		Ø I	
		mm	inch	mm	inch	mm	inch	mm	inch	mm	inch	mm	inch	mm	inch	mm	inch	mm	inch	mm	inch
R50A	11	65	2,56	45	1,77	20	0,79	30	1,18	28	1,10	44	1,73	14	0,55	9	0,35	10	0,39	11	0,43
R75A	11	80	3,15	45	1,77	28,3	1,11	27,8	1,09	28	1,10	57	2,24	14	0,55	9	0,35	10	0,39	14	0,55
R95A	11	95	3,74	45	1,77	42,4	1,67	31,2	1,23	28	1,10	70	2,76	14	0,55	9	0,35	10	0,39	14	0,55

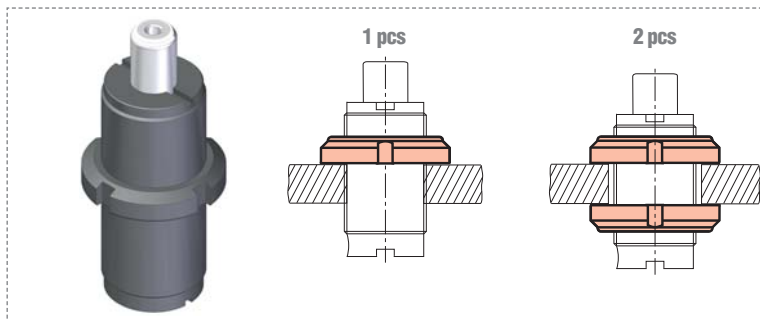
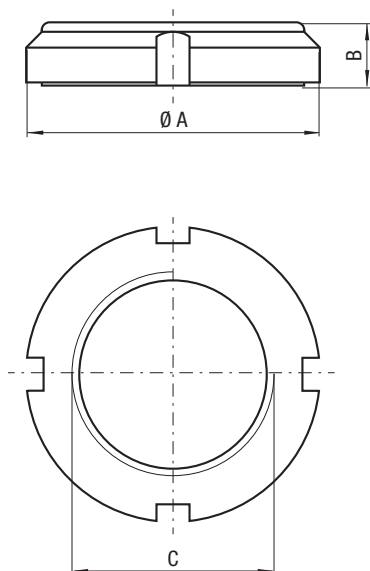

CODE (1 pcs)	Reference to standards	$\varnothing A$		B		C
		mm	inch	mm	inch	
GM38	0	53	2.09	12	0.47	M 38 X 1,5
GM45	0	62	2.44	12,3	0.48	M 45 X 1,5
GM50	0	68	2.68	12,9	0.51	M 50 X 1,5

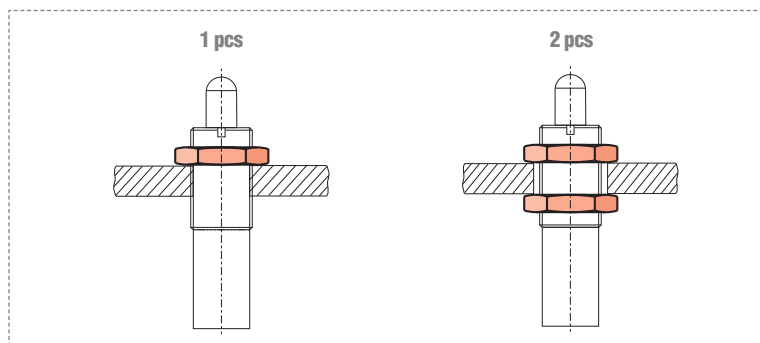
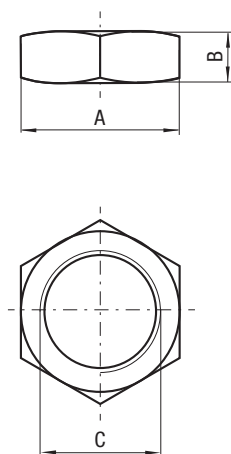

CODE (1 pcs)	Reference to standards	A	B		C
			mm	inch	
DM 16	0-28	S24	8	0,31	M 16 x 1,5
39DM16X2A	0	S24	8	0,31	M 16 x 2
DM 24	0-28	S36	10	0,39	M 24 x 1,5
DI 1" - 8	0	S38	14	0,55	1" - 8



THIS PAGE IS INTENTIONALLY LEFT BLANK

easy

MANIFOLD

since 1997 ■

the easy way
to link nitrogen cylinders through plate



OSAS
Over Stroke
Active Safety



USAS
Uncontrolled Speed
Active Safety



OPAS
Over Pressure
Active Safety



SKUDO
Active Protection
from Contaminants

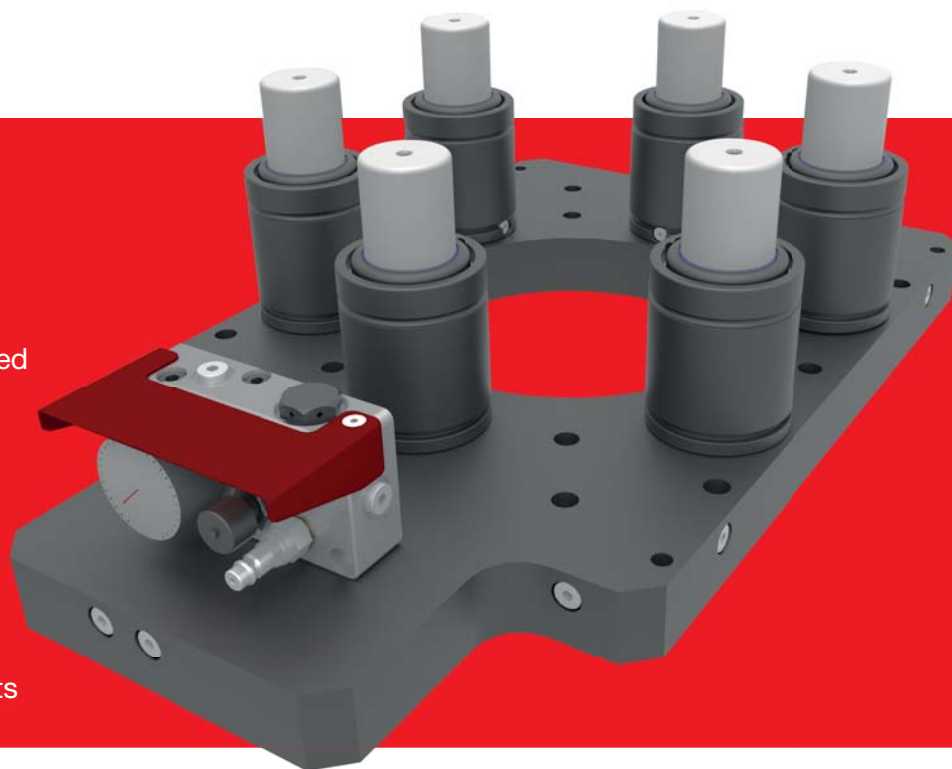

easy
MANI
FOLD

E - ED - EV versions

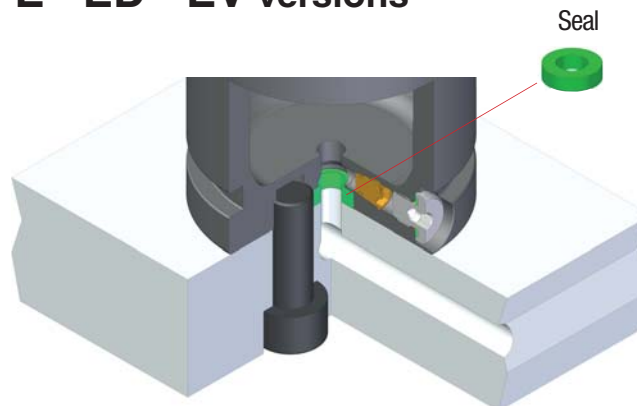

EN version

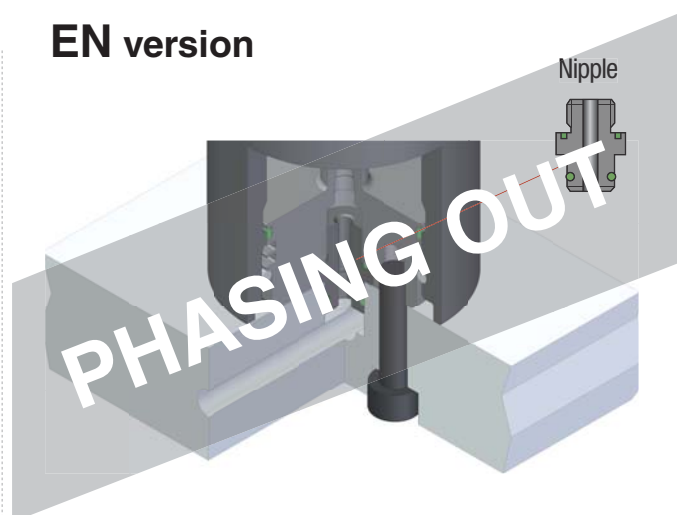

IT CARATTERISTICHE

- Vantaggiosa alternativa ai tradizionali e costosi cilindri Manifold.
- Grande varietà di combinazioni con l'uso di cilindri standard.
- Totale eliminazione di tubi e raccordi.
- Pressione uniforme nel sistema.
- Facile manutenzione, uguale ai cilindri standard.
- Piastre di collegamento realizzabili direttamente dagli utilizzatori.
- Massima flessibilità di realizzazione degli impianti.
- Nessuna richiesta di utensili speciali per l'installazione.
- **Special Springs è in grado di fornire le piastre/cuscino su specifiche del cliente, collaudate e pronte per l'installazione.**

EN CHARACTERISTICS:

- An advantageous alternative to conventional and expensive Manifold cylinders.
- Large variety of combinations with the use of standard cylinders.
- Total elimination of hoses and connections.
- Balanced pressure in the system
- Easy maintenance, the same as standard cylinders.
- Connection plates can be made directly by users.
- Maximum flexibility in creation of systems.
- No special tools required for installation.
- **Special Springs can supply the plates/cushion to customer specifications, tested and ready for installation.**

FR CARACTERISTIQUES:

- Une alternative avantageuse aux traditionnels et coûteux cylindres Manifold.
- Une grande variété de combinaisons avec l'emploi de cylindres standard.
- L'élimination totale de tuyaux et raccords.
- Pression uniforme dans le système
- Entretien facile, comme celui des cylindres standard.
- Plaques de liaison réalisables directement par les utilisateurs.
- Très grande souplesse de réalisation des installations.
- Aucun besoin d'outils spéciaux pour l'installation.
- **Special Springs est en mesure de fournir les plaques/coussin sur spécifications du client, testées et prêtes à être installées.**

ES CARACTERÍSTICAS:

- Ventajosa alternativa a los tradicionales y costosos cilindros Manifold.
- Gran variedad de combinaciones con el uso de cilindros (autónomos) estándar.
- Total eliminación de tubos y racores.
- Presión uniforme en el sistema
- Fácil mantención, igual a la de los cilindros (autónomos) estándar.
- Placas de conexión realizables directamente por los usuarios.
- Máxima flexibilidad de realización de los equipos.
- No se requiere ninguna herramienta especial para la instalación.
- **Special Springs es en grado de proporcionar las placas/cojín sobre especificaciones del cliente, Comprobadas y listas para la instalación.**

DE EIGENSCHAFTEN

- Preisgünstige Alternative zu herkömmlichen Tankplattensystemen.
- Große Auswahl an Einsatzkombinationen durch Verwendung von Standardzylindern.
- Keine Verwendung von Schläuchen und Anschlüssen.
- Gleichmäßiger Druck im System.
- Wartungsfreundlich.
- Verbundplatten können vom Kunden selbst gefertigt werden.
- Hohe Flexibilität bei den Anwendungen.
- Montage ohne Sonderwerkzeuge.
- **Platten können von Special Springs gefertigt, getestet und vormontiert geliefert werden.**

PT CARACTERÍSTICAS:

- Vantajosa alternativa aos tradicionais e caros cilindros Manifold.
- Grande variedade de combinações com uso de cilindros standard.
- Total eliminação de tubos e junções.
- Pressão uniforme em o sistema.
- Fácil manutenção, igual a dos cilindros standard.
- Chapas de conexão que podem ser realizadas diretamente pelos usuários.
- Máxima flexibilidade de realização das instalações.
- Não é necessário utilizar nenhum tipo de utensílio especial para a instalação.
- **Special Springs pode fornecer chapas/coxim conforme exigência do cliente, testadas e verificadas prontas para a instalação.**

Design recommendations

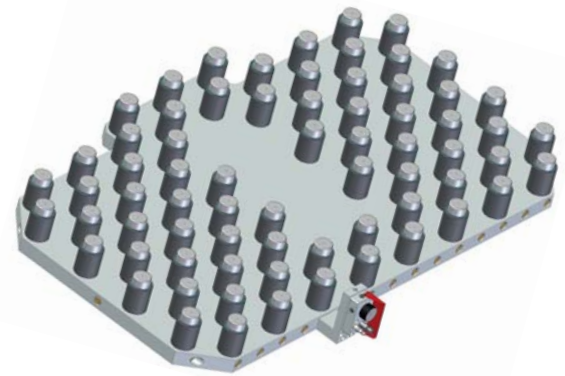
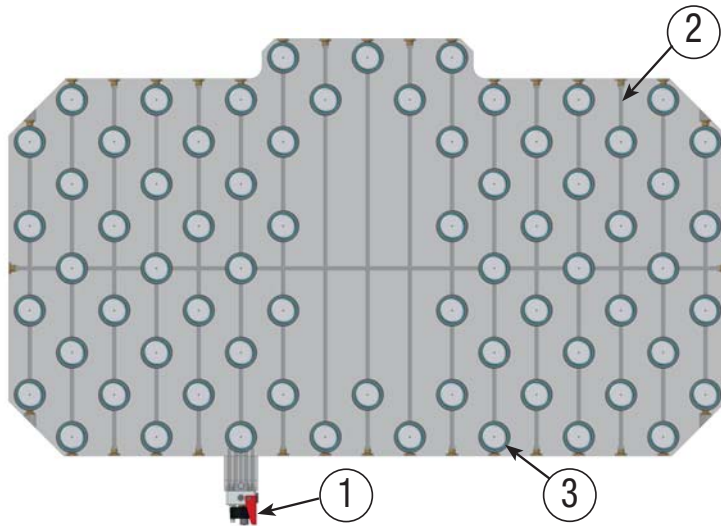

IT Per una facile progettazione e per ridurre i costi di produzione seguire le linee guida di cui sotto

- ① • Per collegare il pannello usare, se possibile, i canali del gas esistenti.
• In alternativa collegare il pannello con tubi e raccordi.
- ② • Realizzare canali passanti e pulire adeguatamente.
• Evitare canali ciechi.
- ③ • Evitare interferenza tra i fori di fissaggio dei cilindri e i canali del gas
• Selezionare cilindri con corse maggiori per aumentare il volume del sistema

FR Pour une conception plus facile et de l'épargne des coûts de fabrications suivez les instructions ci-dessous

- ① • Pour relier le panneau utiliser, si possible, les canaux du gaz existents
• Alternativement, joindre le panneau en utilisant des tubes et des raccords
- ② • Réaliser des trous débouchants et nettoyez correctement
• Eviter les trous sans issue
- ③ • Eviter l'interférence entre les trous de fixation des ressorts et les canaux du gaz
• Sélectionner des ressorts avec des courses majeures pour augmenter le volume du système

DE Für eine bessere Empfehlung und produktionskosten zu speichern, folgen Sie die unteren Richtlinien

- ① • Die Kontrollarmatur, wenn möglich, an den vorhandenen Tieflochbohrungen anbringen
• Alternativ kann die Druckkontrollarmatur mit Schlauchkomponenten angeschlossen werden
- ② • Die Durchgangsbohrungen und Anschlüsse sauber fertigen
• Die Durchgangsbohrungen nicht blind fertigen
- ③ • Abweichungen zwischen der Lage der Befestigungsgewinde und den Verbindungsbohrungen sind zu vermeiden
• Um das Volumen des Systems zu vergrößern, wählen Sie Gasdruckfedern mit dem nächst größeren Hub

EN For easier design and manufacturing cost-saving follow the guide lines below

- ① • When possible, use the existing gas ports to link the panel.
• Alternatively, link the panel by using hoses and connections.
- ② • Machine thru-holes and adequately clear the ports.
• Avoid blind channels.
- ③ • Avoid interference between the cylinder's fixing holes and the gas ports
• Select cylinders with higher stroke to increase the volume of the system

ES Para facilitar el diseño y para ahorrar costes de producción siguen los lineamientos mencionados a continuación

- ① • Para conectar el panel utilizar, si posible, los canales del gas existentes
• En alternativa, conectar el panel con tuberías y conexiones
- ② • Realizar orificios pasantes por toda la placa y bien limpiar
• Evite orificios sin salida
- ③ • Evitar la interferencia entre los orificios de fijacion de los cilindros y los canales de gas
• Seleccionar los cilindros con carreras mas grande para aumentar el volumen del sistema

PT Para facilitar o desenho e economizar custos de produção seguir as orientações abaixo mencionados

- ① • Para ligar o painel, se possível, usar os canais de gás existentes
• Em alternativa conecte o painel com tubos e acessórios
- ② • Realizar orificios de passagem par toda a placa e bem limpar
• Evitar orificios sem saída
- ③ • Evitar a interferência entre os orificios de fixação dos cilindros e os canais de gás
• Escolher os cilindros com curso mais grande para aumentar o volume do sistema

E - ED - EV versions

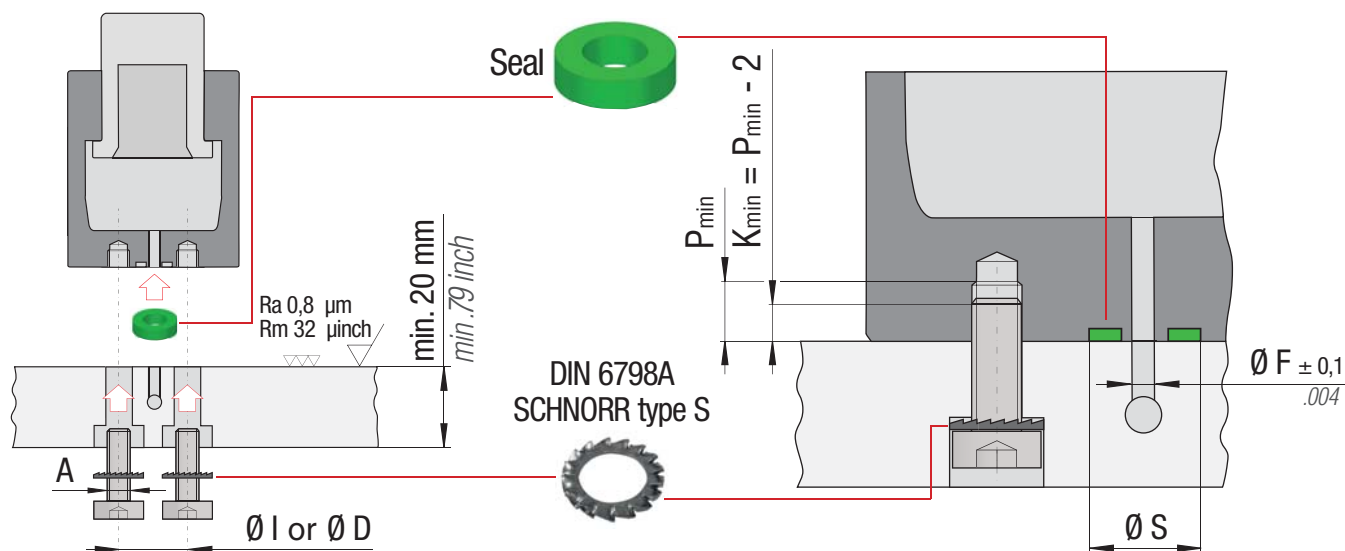

FIXING PATTERN

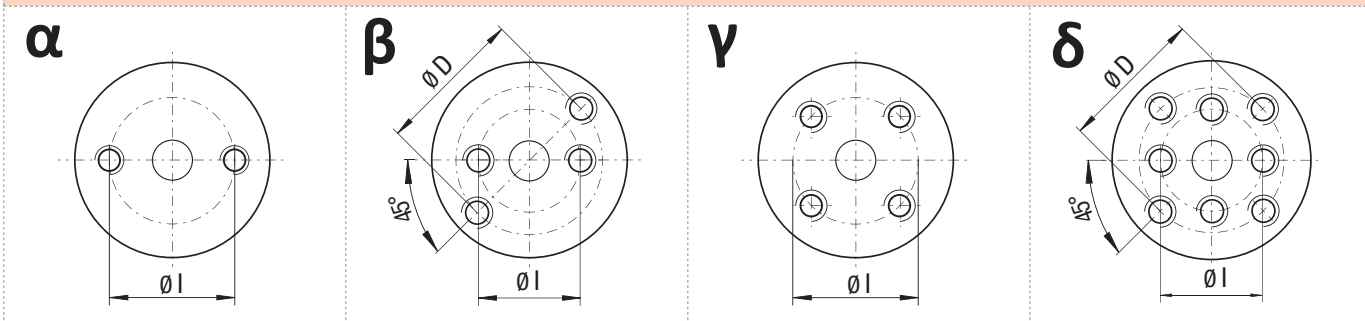

LEGENDA

$\varnothing I$ or $\varnothing D$	A	P _{min}	K _{min}	$\varnothing F$	$\varnothing S$
Interasse fissaggio	Dimensione viti	Min. profondità filetti	Min. impegno viti	\varnothing Foro piastra - cilindro	\varnothing Guarnizione piastra - cilindro
Fixing c.t.c. distance	Screw dimension	Min. thread depth	Min. Thread engagement	\varnothing Plate - Cylinder hole	\varnothing Plate - Cylinder seal
Mittenabstand	Schraubengröße	Min. Gewindetiefe	Min. Einschraubtiefe	\varnothing Platten - Zylinder Loch	\varnothing Platten - Zylinder Dichtung
Entraxe	Dimension vis	Min Profondeur filet	Min recouvrement filetage	\varnothing Trou plaque - cylindre	\varnothing Joint plaque - cylindre
Distancia centros	Tamaño tornillos	Min. profundidad rosca	Min. recubrimiento rosca	\varnothing Agujero Placa - Cilindro	\varnothing Junta Placa - Cilindro
Distância eixos	Dimensão parafusos	Min. profundidade rosca	Min. comprimento rosca	\varnothing Furo Placa - Cilindro	\varnothing Junta Placa - Cilindro

NOTE > see page 214

1

Modello con corpo senza foro di caricamento laterale
 Model with body without side charging port
 Model mit Körper ohne Nebenladeloch
 Modèle avec corps sans trou de charge latéral
 Modelo con cuerpo sin hueco de carga
 Modelo com corpo sem orifício de carregamen

2

Modello con corpo liscio senza cave di fissaggio
 Model with straight body without fixing grooves
 Model mit flachem Körper ohne Befestigungsnuten
 Modèle avec corps lisse sans encoches de fixation
 Modelo con cuerpo parejo sin ranuras de fijación
 Modelo com corpo liso sem ranhuras de fixação



IT Corse e ingombri uguali al cilindro autonomo
EN Strokes and sizes same to selfcontained cylinder
DE Hüben und Abmessungen gleiche zu den Autonomen Gdf

FR Courses et ecombement égaux à ceux du Cylindre autonome
ES Carreras y dimensiones iguales a las del cilindro autónomo
PT Cursos e dimensões iguais às do cilindro autónomo

Easy manifold control panel

code 39CP01A

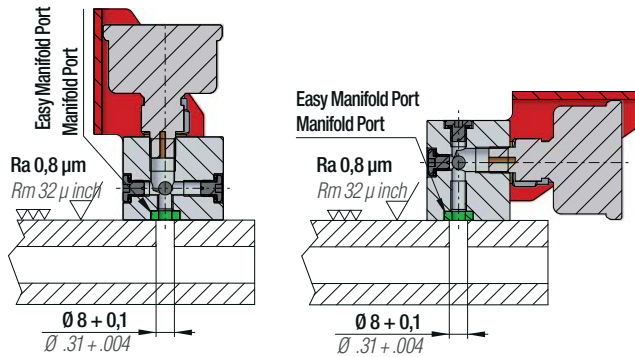
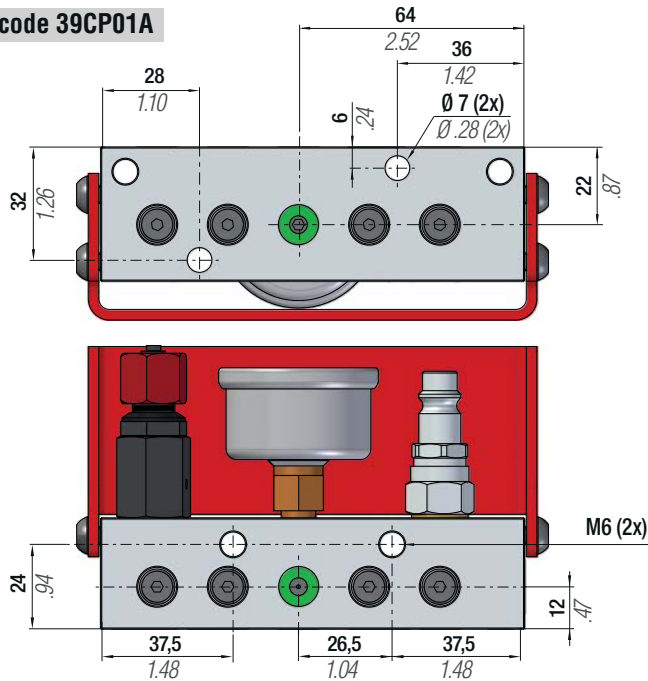

code 39CPVC

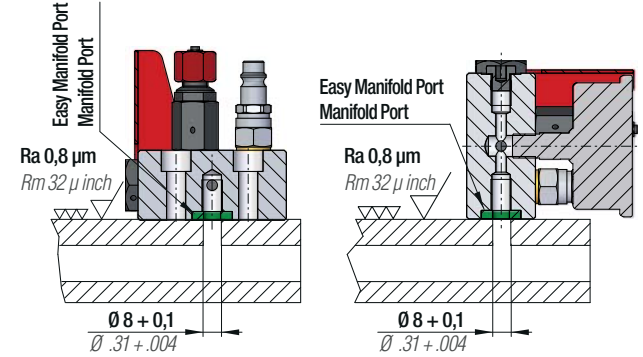
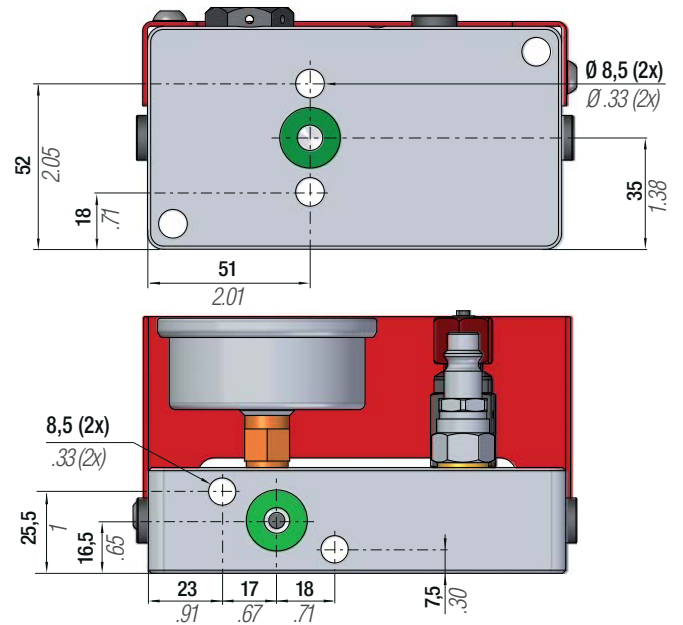

code 39MCPC

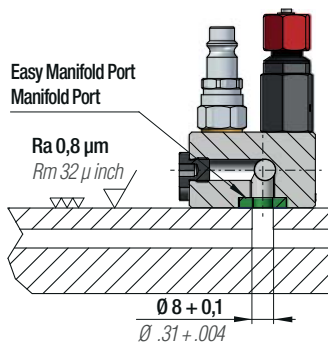
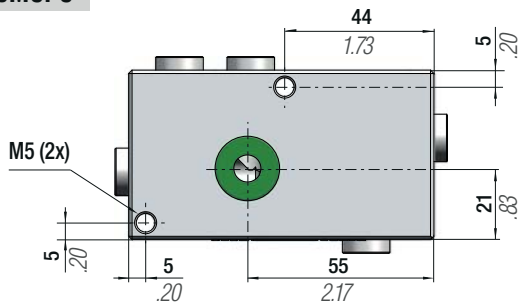

code 39CP14A

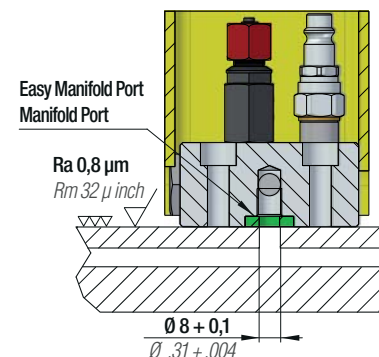
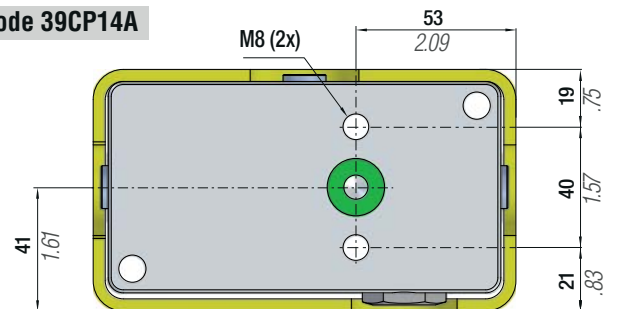

How to plug holes

IT Quando è richiesta una riduzione della forza del sistema, o del numero di cilindri, è possibile tappare i fori non utilizzati con una copertura dotata di guarnizione, che utilizza gli stessi fissaggi dei cilindri.

FR Quand une réduction de la force du système ou du nombre des vérins est requise, on peut boucher les trous qui ne sont pas utilisés, avec un couvercle équipée avec un joint, qui utilise les mêmes trous de fixations des vérins.

EN When a reduction either of the system's force, or of the number of cylinders, is required, it is possible to plug the holes which are not used, with a cover provided with a square seal, through the same fixing hoses of the cylinders.

ES Cuando se necesita de una reducción de la fuerza del sistema, o del número de cilindros, puede tapar los agujeros no utilizados con una cobertura equipada de junta, que utiliza los mismos agujeros de los cilindros.

DE Mit den Verschlussplatten werden nicht benötigte Bohrungen verschlossen und abgedichtet. Dadurch können einzelne Gasdruckfedern aus einem System entfernt und Kräfte in einem bestimmten Bereich reduziert werden.

PT Quando você solicita uma redução na força do sistema, ou o número de cilindros, pode tapar os buracos não utilizados com uma tampa com vedação, que usa o mesmo buracos dos cilindros.

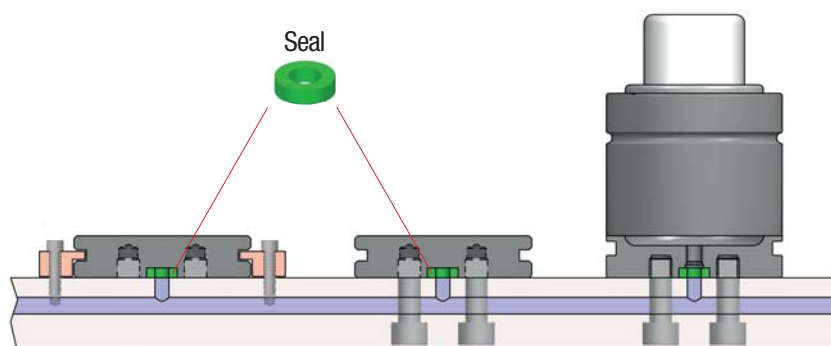
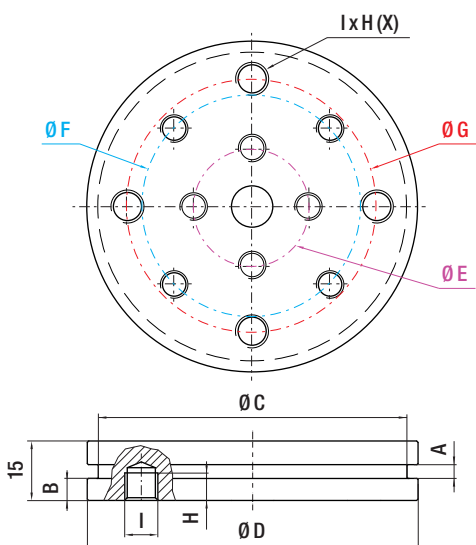

Code	A		B		Ø C		Ø D		Ø E		Ø F		Ø G		I (x)	H	Seal Code	Fixing								
	mm	inch	mm	inch	mm	inch	mm	inch	mm	inch	mm	inch	mm	inch												
39TE012A	3,5	0.14	4	0.16	27	1.06	32	1.26	18	0.71	-	-	-	-	M6 (2x)	10	0.39	50GE02A	FS2.. 32							
39TE010A					20	0.79	24	0.94	-	-	-	-	M6 (4x)													
39TE001A					33	1.3	38	1.50	20	0.79	-	-	-	-	M8 (2x)											
39TE011A					40	1.06	45	1.77	26	1.02	-	-	-	-	M8 (4x)											
39TE002A	5	0.20	8	0.31	40	1.57	45	1.77	26	1.02	-	-	-	-	M8 (4x)	10	0.39	50GE01A	FS2.. 45							
39TE003A					43	1.69	50	1.97	26	1.02	-	-	-	-	M6 (4x)											
39TE009A					56	2.2	63	2.48	34	1.34	-	-	-	-	M8 (4x)											
39TE004A					67	2.64	75	2.95	40	1.57	-	-	-	-	M12 (4x)											
39TE005A					87	3.43	95	3.74	52	2.05	60	2.36	-	-	M8 (4x)											
39TE006A					-	-	-	-	-	-	-	76,2	3.00	-	-					M12 (4x)						
					112	4.41	120	4.72	80	3.15	-	-	68	2.68	-					M10 (4x)						
39TE007A					-	-	-	-	-	-	-	80,8	3.18	-	-					M12 (4x)						
					142	5.59	150	5.91	100	3.94	-	-	90	3.54	-					M10 (4x)						
39TE008A					8	0.31	-	-	187	7.36	195	7.68	120	4.72	-					-	-	M12 (4x)	FS2.. 150			
																										FS2.. 195

Mounting recommendations

⚠ It is always required Loctite 243 or equivalent

Chiave dinamometrica
Torque wrench
Drehmomentschlüssel
Clé dynamométrique
Llave dinamométrica
Chave dinamométrica

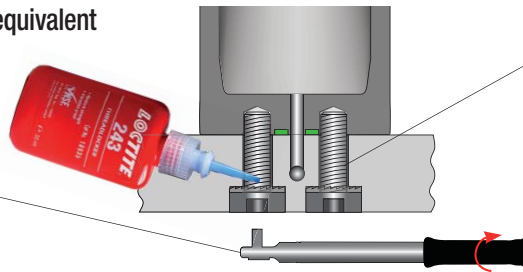

Torque force

M6	class 8.8	max 10,4 Nm
M8	class 8.8	max 24,6 Nm
M10	class 8.8	max 52,4 Nm
M12	class 8.8	max 90 Nm

IT Raccomandazioni

- L'uso di viti di classe superiore alla 8.8, come 9.8, 10.9 e 12.9, è sempre possibile.
- Si raccomanda di NON SUPERARE i valori della coppia di serraggio indicati per la classe 8.8 per qualsiasi classe di viti utilizzata.
- Impegnare sempre il filetto il più possibile, almeno il valore di Kmin.
- Utilizzare SEMPRE i fori di fissaggio previsti.
- Massima attenzione nel montaggio della guarnizione di collegamento tra cilindro e piastra

- Massima attenzione alla corretta coppia di serraggio da applicare alle viti
- Usare SEMPRE rondelle anti svitamento su cilindri e pannelli
- Usare SEMPRE frena filetti tipo Loctite 243 su cilindri e pannelli
- Non caricare il sistema Easy Manifold con pressione superiore alla massima consentita per specifico modello di cilindro

EN Recommendations

- The use of screws of higher class than 8.8, such as 9.8, 10.9 and 12.9, is always allowed.
- DO NOT EXCEED the fixed values for torque force indicated for class 8.8, in any other class of screws used.
- ALWAYS engage thread as much as possible at least Kmin.
- ALWAYS use the fixing holes provided.
- Extreme caution when assembling the connecting seal between plate and cylinder

- Extreme caution to tightening torque to be applied to screws
- ALWAYS use lock washers on cylinders and panels.
- ALWAYS use thread lock LOCTITE 243 on cylinders and panels.
- Do not charge the easy manifold system over the maximum allowed pressure for each cylinder model

DE Hinweise

- Schrauben mit einer Festigkeit von 8.8 verwenden. Höhere Festigkeitsklassen wie 9.8, 10.9 und 12.9 sind möglich.
- Das Drehmoment der Festigkeitsklasse 8.8 für andere Festigkeitsklassen nicht überschreiten
- Die komplette Gewindelänge ausnutzen, mind. Kmin
- Alle Befestigungsgewinde verwenden
- Vorsicht bei der Montage der Dichtungen zwischen den Gasdruckfedern und der Platte

- Äußerste Vorsicht bzgl. des korrekten Drehmoments beim Einschrauben
- IMMER Sicherungsscheiben auf die Zylindern und Kontrollarmaturen, verwenden
- IMMER eine Schraubensicherung wie z.B. Loctite 243 auf die Zylindern und Kontrollarmaturen, verwenden
- Das Easy Manifold System nicht mit einem höheren Druck laden als dem, der speziell für das Modell der Gasdruckfeder empfohlen wird

FR Reccomandacions

- L'usage de vis de classe supérieure au 8.8, tout comme 9.8, 10.9 et 12.9, est toujours possible.
- N'EXCEDEZ PAS la valeur de la couple de serrage indiqués pour la classe 8.8 pour n'importe quelle autre classe de vis utilisée.
- Engager toujours le filetages plus que possible, et au moins Kmin.
- Utiliser TOUJOURS les trous de fixation prévus.
- Une extrême vigilance est recommandée pour l'assemblage du joint entre la plaque et le vérin

- Bien veiller à appliquer le couple de serrage correct aux vis
- TOUJOURS utiliser les rondelles de verrouillage avec les cylindres et les panneaux
- TOUJOURS utiliser la colle frein filet LOCTITE 243 avec les cylindres et les panneaux.
- Ne pas charger le système manifold au delà de la pression autorisée pour chaque modèle de vérin.

ES Recomendaciones

- La utilización de los tornillos superiores a 8,8, como 9,8, 10,9 y 12,9, siempre es posible.
- Le recomendamos que NO HAY QUE SUPERAR los valores de las especificaciones de torsión para tornillos de clase 8.8 utilizados para cualquier clase.
- Siempre enganchar la rosca tanto como sea posible, al menos para Kmin.
- SIEMPRE use los agujeros de fijación previstos
- Máxima atención en el montaje de la junta de conexión entre placa y cilindro.

- Máxima atención al correcto par de torsión que se aplica a los tornillos.
- Utilizar SIEMPRE arandelas autoblocantes por los cilindros y paneles.
- Utilizar SIEMPRE fijador de rosca tipo Loctite 243 por los cilindros y paneles.
- No cargar el sistema Easy Manifold con presión superior a la máxima permitida para cada tipo de cilindro.

PT Recomendações

- O uso de limitadores superiores a 8,8, tal como 9,8, 10,9 e 12,9, é sempre possível.
- Recomendamos que você NÃO ULTRAPASSE os valores das especificações de torque para a classe 8,8 por os limitadores utilizados para qualquer classe.
- Sempre envolver a rosca, tanto quanto possível, pelo menos para Kmin.
- Use SEMPRE os furos de fixação fornecidos.
- Máxima atenção quando fixar os vedantes conectores entre a placa e cilindro

- Máxima atenção no torque de aperto aplicado nos parafusos
- Utilizar SEMPRE as anilhas de travamento nos cilindros e painéis.
- Utilizar SEMPRE o fixador de rosca LOCTITE 243 nos cilindros e painéis.
- Não carregar o sistema EASY MANIFOLD acima da pressão máxima recomendada para cada modelo de cilindro

MANIFOLD SYSTEM

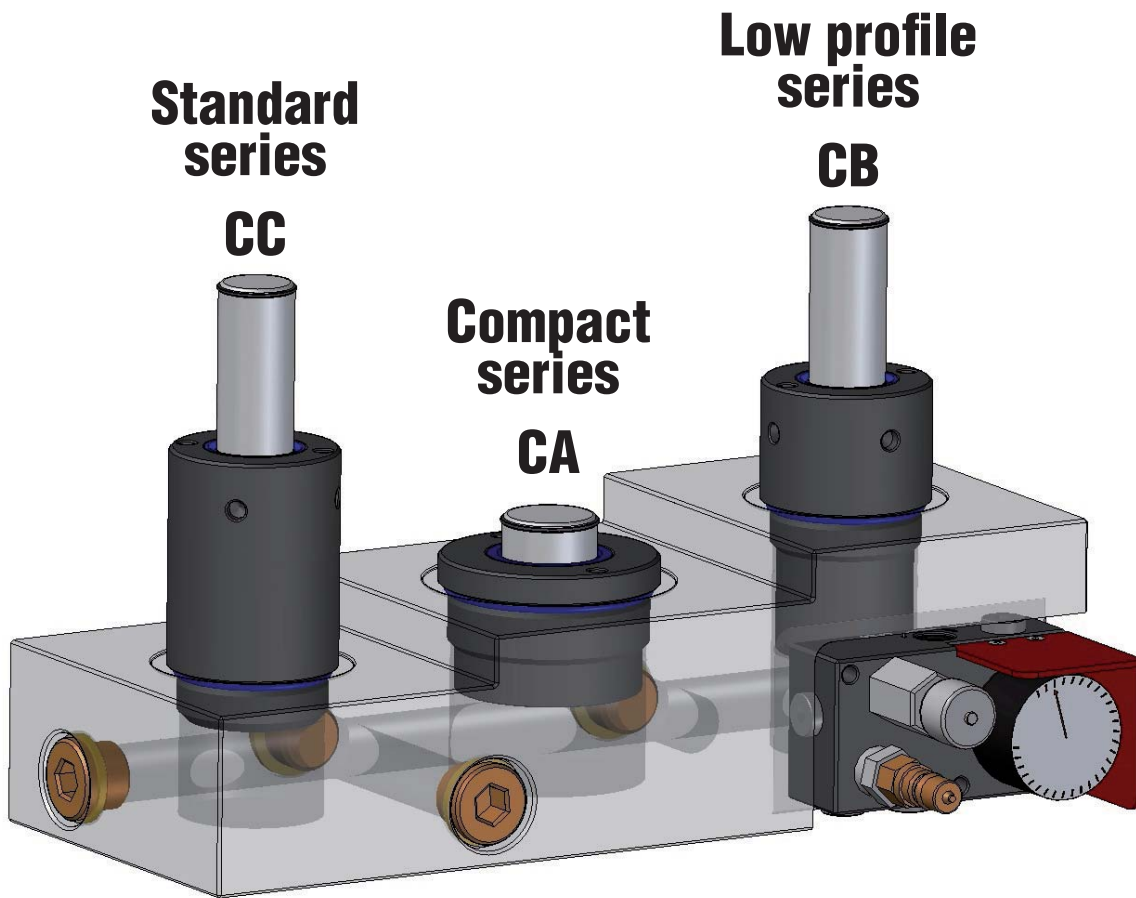

IT SISTEMA MANIFOLD

- Alternativa ai cilindri autonomi collegati
- Minimo incremento di pressione e forza
- Minimo ingombro
- Assenza di tubi e raccordi
- Grandi forze concentrate
- Monitoraggio e modifica della pressione facilitati attraverso il pannello di controllo
- Facilità di montaggio
- Facilità di manutenzione
- Lunga durata

CARATTERISTICHE TECNICHE

- Cilindri con tenuta pistone
- Raschiatore di protezione da contaminanti
- Doppia guida autolubrificata
- Corpo cilindro nitratato con durezza ~ Hv 700
- Corpo cilindro lappato con rugosità ~ Ra ≤ 0,05 μ
- Stelo pistone nitratato con durezza ~ Hv 700
- Stelo pistone lappato con rugosità ~ Ra ≤ 0,05 μ
- Pressione massima di caricamento 110 bar a 20°C
- Pressione minima di caricamento 30 bar a 20°C
- Velocità massima 0,6 m/sec
- Progettati in conformità alla Direttiva PED 2014/68/EU e EN 13445:2015

DE TANKPLATTENSYSYSTEM

- Alternativ zu Gasdruckfedern in Verbundanordnung
- Sehr geringer Druck- bzw. Kraftanstieg
- Kleine Einbaubmessungen
- Keine Schlauchverbindungen nötig
- Hohe Kräfte auf engstem Raum
- Einfache Überwachung und Druckänderung über Kontrollarmatur
- Leichte Montage
- Einfache Wartung
- Lange Lebensdauer

TECHNISCHE DATEN

- Gasdruckfedern mit Kolbendichtung
- Schmutzabstreifer
- Doppelte selbstschmierende Führung
- Nitrierter Zylinderkörper, Härte ~ Hv 700
- Geläppter Zylinderkörper, Rauigkeit ~ Ra ≤ 0,05 μ
- Kolbenstange nitriert, Härte ~ Hv 700
- Geläppte Kolbenstange, Rauigkeit ~ Ra ≤ 0,05 μ
- Max. Fülldruck 110 bar bei 20 °C
- Min. Fülldruck 30 bar bei 20 °C
- Max. Kolbengeschwindigkeit 0,6 m/s
- Konstruktion nach Druckgeräterichtlinie PED 2014/68/EU und EN 13445:2015

ES SISTEMA MANIFOLD

- Alternativa a los cilindros autónomos conectados
- Incremento mínimo de presión y fuerza
- Dimensiones mínimas
- Ausencia de tubos y conectores
- Concentración de grandes fuerzas
- Monitorización y modificación de la presión asignada a través del panel de control
- Facilidad de montaje
- Facilidad de mantenimiento
- Larga vida útil

CARACTERÍSTICAS TÉCNICAS

- Cilindros con guarnición en el pistón
- Escudo protector de agentes externos contaminantes
- Doble guía autolubrificada
- Cuerpo del cilindro nitratado con dureza ~ Hv 700
- Cuerpo del cilindro lapeado con rugosidad ~ Ra ≤ 0,05 μ
- Vástago nitratado con dureza ~ Hv 700
- Vástago lapeado con rugosidad ~ Ra ≤ 0,05 μ
- Presión máxima de carga 110 bar a 20°C
- Presión mínima de carga 30 bar a 20°C
- Velocidad máxima 0,6 m/s
- Diseñados de acuerdo a la Directiva PED 2014/68/EU y EN 13445:2015

EN MANIFOLD SYSTEM

- Alternative choice to hose system
- Low increase of force and pressure
- Minimal heights
- No hoses and/or fittings
- Highest force in the minimum space
- Easy check and charge of pressure through the panel
- Easy mounting
- Easy maintenance
- Long lasting

TECHNICAL FEATURES

- Piston sealed cylinders
- Rod wiper against contaminants
- Double self lubricating guiding elements
- Nitred body with hardness of ~ Hv 700
- Lapped body with roughness of ~ Ra ≤ 0,05 μ
- Nitred piston rod with hardness of ~ Hv 700
- Lapped piston rod with roughness of ~ Ra ≤ 0,05 μ
- Maximum charging pressure 110 bar a 20°C
- Minimum charging pressure 30 bar a 20°C
- Maximum speed 0,6 m/sec
- In compliance with PED 2014/68EU and EN 13445:2015 Directive

FR SYSTÈME MULTIPLE

- Solution alternative au système interconnecté par tuyaux
- Faible augmentation de la force et de la pression
- Hauteurs minimales
- Utilisation d'aucun tuyau ni adaptateur
- Force maximale pour un encombrement minimum
- Vérification aisée de la pression et rechargement facilité grâce au dispositif de gonflage
- Montage facile
- Maintenance facilitée
- Longévité optimale

CARACTÉRISTIQUES TECHNIQUES

- Vérins avec joint de piston
- Dévêtisseur protégeant de la poussière et de tous contaminants
- Doubles éléments de guidage auto-lubrifiants
- Corps trempé à ~Hv 700
- Corps rodé avec rugosité de ~Ra ≤ 0,05 μ
- Piston nituré, dureté de ~Hv 700
- Piston rodé avec rugosité de ~Ra ≤ 0,05 μ
- Pression de charge maximale 110 bar à 20°C
- Pression de charge minimale 30 bar à 20°C
- Vitesse maximale 0,6 m/sec
- Conformément à la directive PED2014/68/EU et EN 13445:2015

PT SISTEMA MANIFOLD

- Alternativa aos cilindros autónomos interligados
- Incremento mínimo de pressão e força
- Mínimo espaço
- Ausência de tubos e "racords"
- Grande força concentrada
- Monitorização e modificação da pressão facilitada através do painel de controlo
- De fácil montagem
- De fácil manutenção
- Longa duração

CARACTERÍSTICAS TÉCNICAS

- Cilindros com estanquidade do êmbolo
- Raspador para protecção contra contaminantes
- Duplo guiamento autolubrificado
- Corpo do cilindro nitratado com dureza - Hv 700
- Corpo do cilindro polido com rugosidade ~Ra ≤ 0,05 μ
- Êmbolo nitratado com dureza - Hv 700
- Êmbolo polido com rugosidade ~Ra ≤ 0,05 μ
- Pressão máxima de carregamento 110 bar a 20°C
- Pressão mínima de carregamento 30 bar a 20°C
- Velocidade máxima 0,6 m/s
- Projectados em conformidade com a Directiva PED 2014/68/EU e EN 13445:2015

PED
2014/68/EU

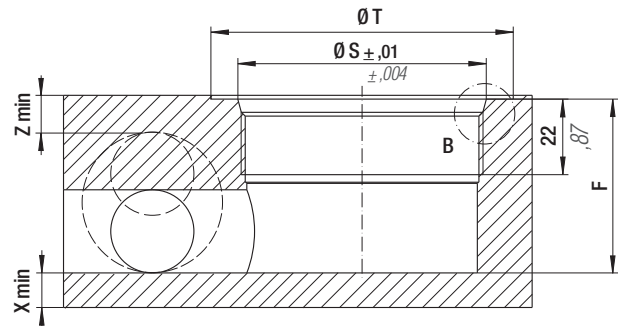
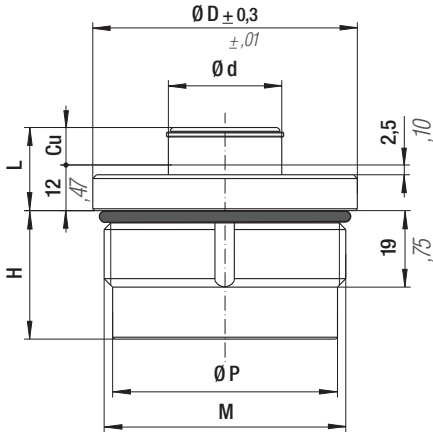
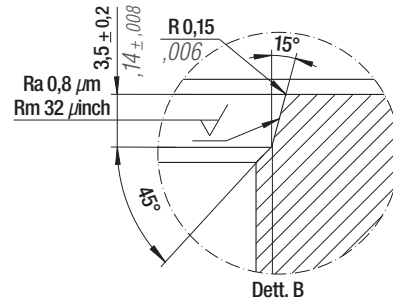
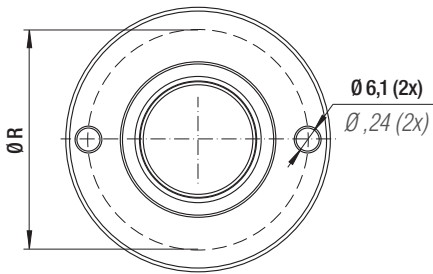

Max Speed 0,8 m/s		N₂	P max 110 bar 1595 psi	P min 20 bar 290 psi	S 22,9 cm ² 3,55 in ²		Maintenance kit 39BMCA02500A
-----------------------------	--	----------------------	-------------------------------------	-----------------------------------	--	--	--

MODEL	F ₀		M	Cu		L		H		Ø D		Ø d		Ø P		Ø R		Ø T		Ø S		F	Xmin		Zmin		
	daN	lb		mm	inch	mm	inch	mm	inch	mm	inch	mm	inch	mm	inch	mm	inch	mm	inch	mm	inch		mm	inch	mm	inch	mm
CA 2500 - 006 - A	2520	5665	M 64 X 2	6	0.24	18	0.71	30	1.18	70	2.76	30	1.18	59,5	2.34	58	2.28	80	3.15	65,9	2.59	33	1.30	10	0.39	8	0.31
CA 2500 - 010 - A	2520	5665	M 64 X 2	10	0.39	22	0.87	34	1.34	70	2.76	30	1.18	59,5	2.34	58	2.28	80	3.15	65,9	2.59	37	1.46	10	0.39	8	0.31
CA 2500 - 015 - A	2520	5665	M 64 X 2	15	0.59	27	1.06	39	1.54	70	2.76	30	1.18	59,5	2.34	58	2.28	80	3.15	65,9	2.59	42	1.65	10	0.39	8	0.31
CA 2500 - 020 - A	2520	5665	M 64 X 2	20	0.79	32	1.26	44	1.73	70	2.76	30	1.18	59,5	2.34	58	2.28	80	3.15	65,9	2.59	47	1.85	10	0.39	8	0.31

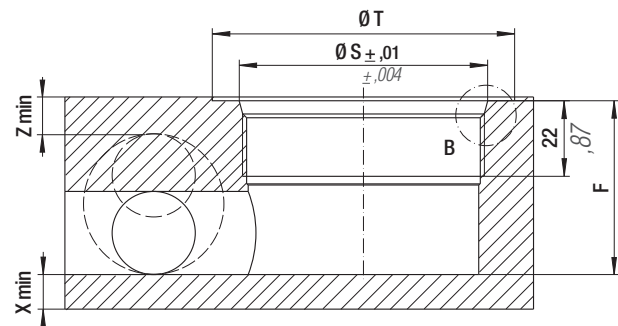
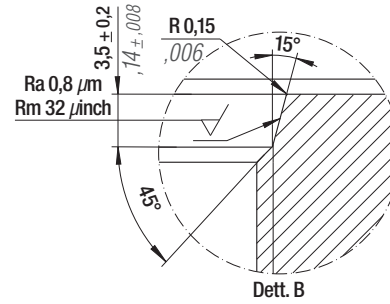
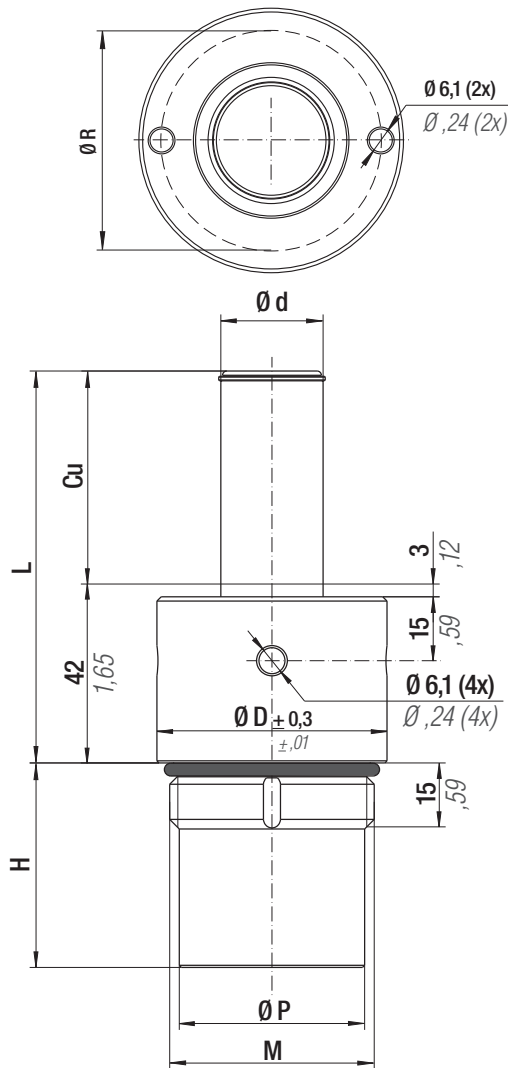

Max Speed: 0,8 m/s			P max 110 bar 1595 psi	P min 20 bar 290 psi	S 9,62 cm ² 1,49 in ²		Maintenance kit 39BMCC01000A
------------------------------	--	--	-------------------------------------	-----------------------------------	--	--	--

MODEL	Fo		M	Cu		L		H		Ø D		Ø d		Ø P		Ø R		Ø T		Ø S		F		Xmin		Zmin	
	daN	lb		mm	inch	mm	inch	mm	inch	mm	inch	mm	inch	mm	inch	mm	inch	mm	inch	mm	inch	mm	inch	mm	inch	mm	inch
CB 1000 - 025 - A	1060	2383	M 48 X 2	25	0,98	67	2,64	23	0,91	54	2,13	24	0,95	43,5	1,71	44	1,73	64	2,52	49,9	1,97	26	1,02	10	0,39	8	0,31
CB 1000 - 038 - A	1060	2383	M 48 X 2	38	1,50	80	3,15	36	1,42	54	2,13	24	0,95	43,5	1,71	44	1,73	64	2,52	49,9	1,97	39	1,54	10	0,39	8	0,31
CB 1000 - 050 - A	1060	2383	M 48 X 2	50	1,97	92	3,62	48	1,89	54	2,13	24	0,95	43,5	1,71	44	1,73	64	2,52	49,9	1,97	51	2,01	10	0,39	8	0,31
CB 1000 - 075 - A	1060	2383	M 48 X 2	75	2,95	117	4,61	73	2,87	54	2,13	24	0,95	43,5	1,71	44	1,73	64	2,52	49,9	1,97	76	2,99	10	0,39	8	0,31
CB 1000 - 100 - A	1060	2383	M 48 X 2	100	3,94	142	5,59	98	3,86	54	2,13	24	0,95	43,5	1,71	44	1,73	64	2,52	49,9	1,97	101	3,98	10	0,39	8	0,31
CB 1000 - 150 - A	1060	2383	M 48 X 2z	150	5,91	192	7,56	148	5,83	54	2,13	24	0,95	43,5	1,71	44	1,73	64	2,52	49,9	1,97	151	5,94	10	0,39	8	0,31

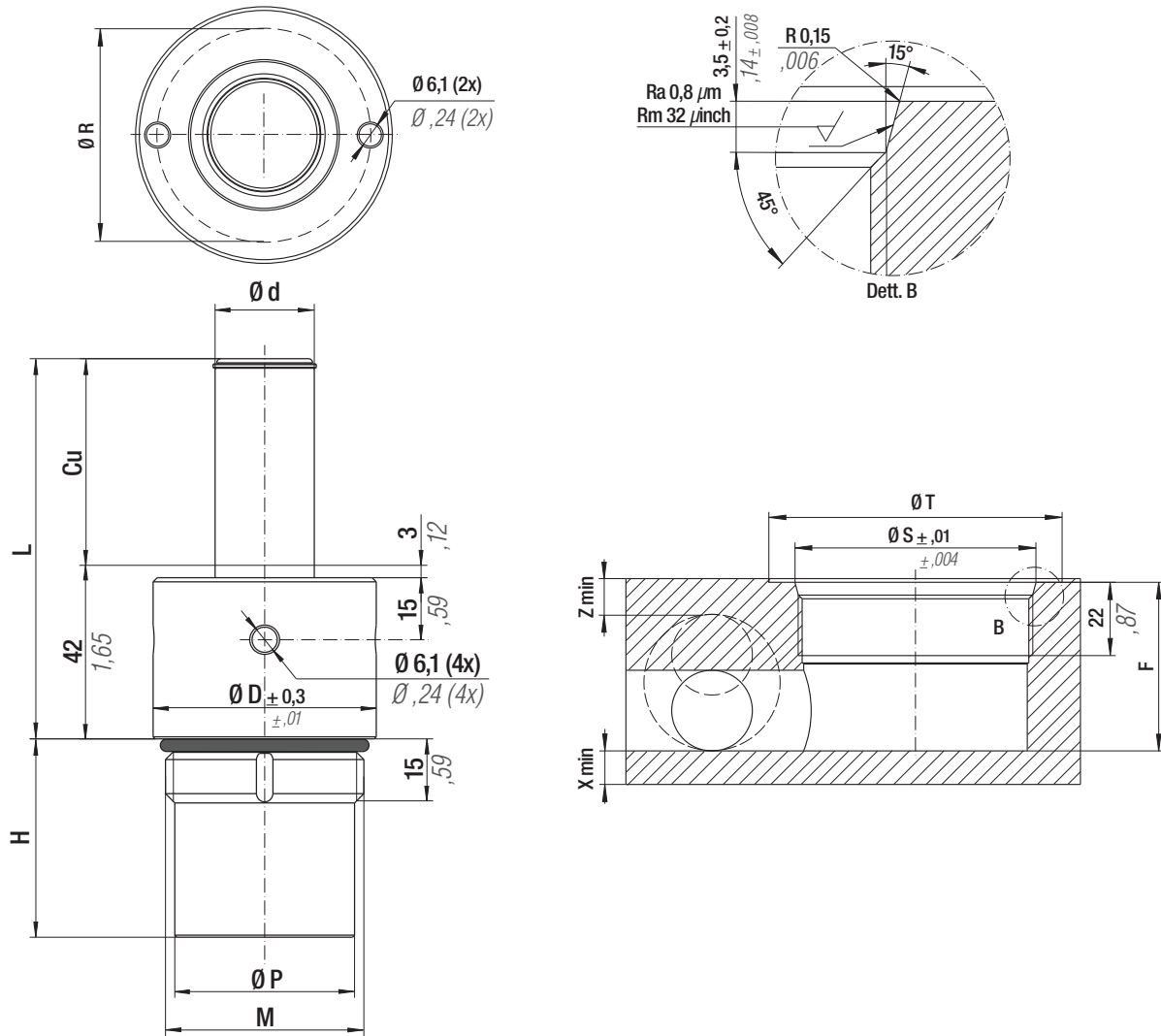

Max Speed 0,8 m/s	°F 32 176	°C 0 80	N₂	P max 110 bar 1595 psi	P min 20 bar 290 psi	S 22,9 cm ² 3,55 in ²		Maintenance kit 39BMCB02500A
-----------------------------	------------------------	----------------------	----------------------	-------------------------------------	-----------------------------------	--	--	--

MODEL	F ₀		M	Cu		L		H		Ø D		Ø d		Ø P		Ø R		Ø T		Ø S		F		X min		Z min	
	daN	lb		mm	inch	mm	inch	mm	inch	mm	inch	mm	inch	mm	inch	mm	inch	mm	inch	mm	inch	mm	inch	mm	inch	mm	inch
CB 2500 - 025 - A	2520	5665	M 64 X 2	25	0.98	67	2.64	23	0.91	70	2.76	30	1.18	59,5	2.34	58	2.28	80	3.15	65,9	2.59	26,0	1.02	10	0.39	8	0.31
CB 2500 - 038 - A	2520	5665	M 64 X 2	38	1.5	80	3.15	36	1.42	70	2.76	30	1.18	59,5	2.34	58	2.28	80	3.15	65,9	2.59	39,0	1.54	10	0.39	8	0.31
CB 2500 - 050 - A	2520	5665	M 64 X 2	50	1.97	92	3.62	48	1.89	70	2.76	30	1.18	59,5	2.34	58	2.28	80	3.15	65,9	2.59	51,0	2.01	10	0.39	8	0.31
CB 2500 - 075 - A	2520	5665	M 64 X 2	75	2.95	117	4.61	73	2.87	70	2.76	30	1.18	59,5	2.34	58	2.28	80	3.15	65,9	2.59	76,0	2.99	10	0.39	8	0.31
CB 2500 - 100 - A	2520	5665	M 64 X 2	100	3.94	142	5.59	98	3.86	70	2.76	30	1.18	59,5	2.34	58	2.28	80	3.15	65,9	2.59	101,0	3.98	10	0.39	8	0.31
CB 2500 - 150 - A	2520	5665	M 64 X 2	150	5.91	192	7.56	148	5.83	70	2.76	30	1.18	59,5	2.34	58	2.28	80	3.15	65,9	2.59	151,0	5.94	10	0.39	8	0.31

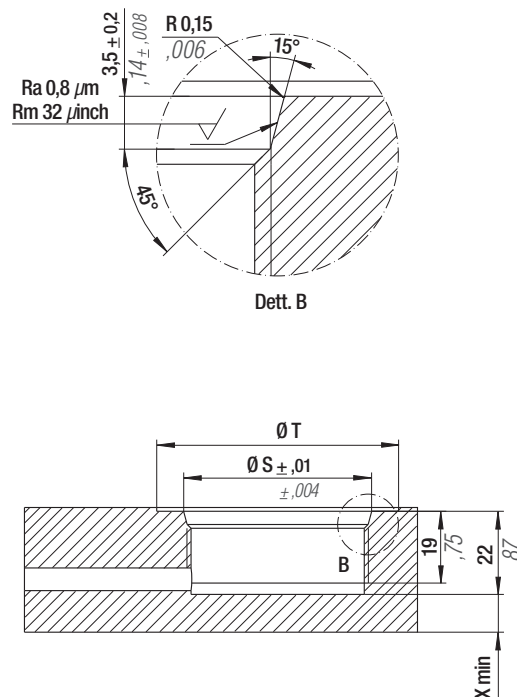
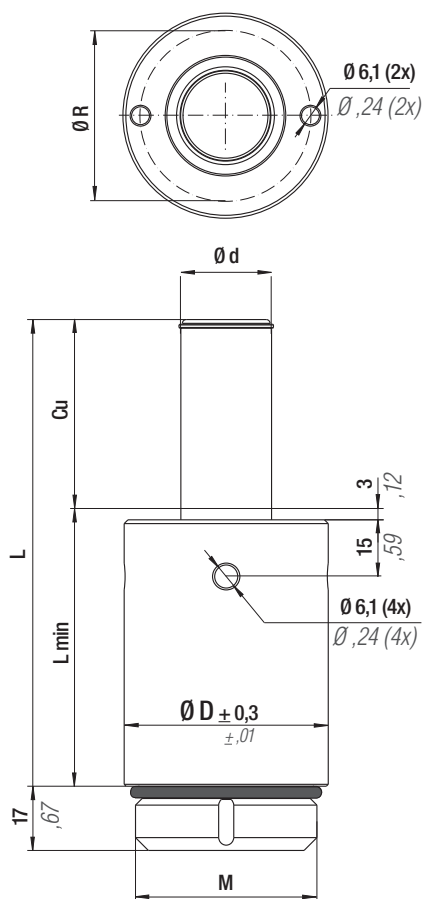

MODEL	F ₀		M	Cu		L		L min		Ø D		Ø d		Ø R		Ø T		Ø S		Xmin	
	daN	lb		mm	inch	mm	inch	mm	inch	mm	inch	mm	inch	mm	inch	mm	inch	mm	inch	mm	inch
CC 0500 - 012 - A	540	1214	M 36 X 2	12,5	0.49	45,5	1.79	33,0	1.30	42	1.65	12	0.47	32	1.26	52	2.05	37,9	1.49	6	0.24
CC 0500 - 025 - A	540	1214	M 36 X 2	25	0.98	70,5	2.78	45,5	1.79	42	1.65	12	0.47	32	1.26	52	2.05	37,9	1.49	6	0.24
CC 0500 - 038 - A	540	1214	M 36 X 2	38	1.50	96,5	3.80	58,5	2.30	42	1.65	12	0.47	32	1.26	52	2.05	37,9	1.49	6	0.24
CC 0500 - 050 - A	540	1214	M 36 X 2	50	1.97	120,5	4.74	70,5	2.78	42	1.65	12	0.47	32	1.26	52	2.05	37,9	1.49	6	0.24
CC 0500 - 075 - A	540	1214	M 36 X 2	75	2.95	170,5	6.71	95,5	3.76	42	1.65	12	0.47	32	1.26	52	2.05	37,9	1.49	6	0.24
CC 0500 - 100 - A	540	1214	M 36 X 2	100	3.94	220,5	8.68	120,5	4.74	42	1.65	12	0.47	32	1.26	52	2.05	37,9	1.49	6	0.24

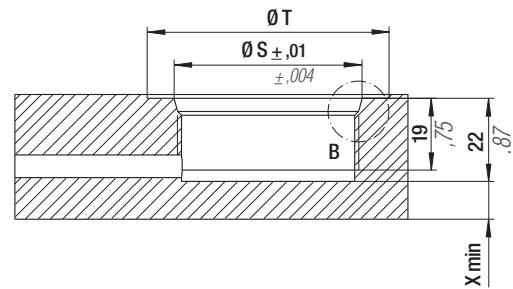
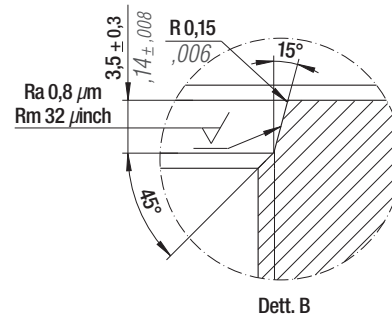
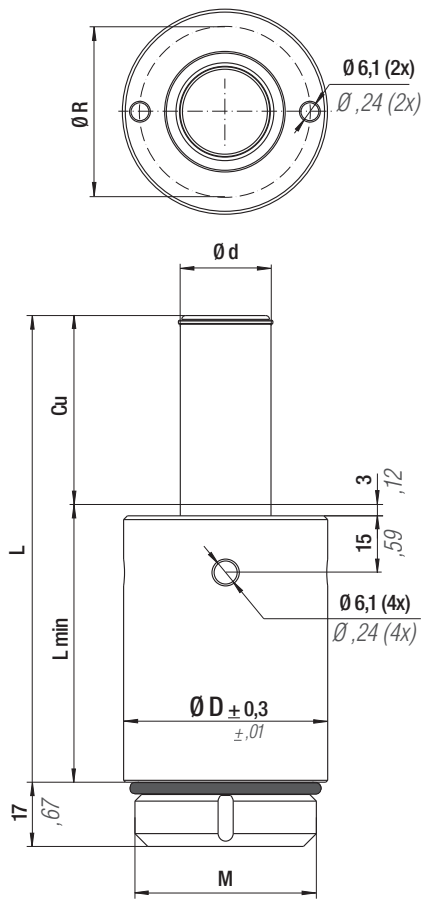

Max Speed 0,8 m/s	°F 32 176	°C 0 80	N₂	P max 110 bar 1595 psi	P min 20 bar 290 psi	S 9,62 cm ² 1,491 in ²		Maintenance kit 39BMCC01000A
-----------------------------	------------------------	----------------------	----------------------	-------------------------------------	-----------------------------------	---	--	--

MODEL	F ₀		M	Cu		L		L min		Ø D		Ø d		Ø R		Ø T		Ø S		Xmin	
	daN	lb		mm	inch	mm	inch	mm	inch	mm	inch	mm	inch	mm	inch	mm	inch	mm	inch	mm	inch
CC 1000 - 025 - A	1060	2383	M 48 X 2	25	0,98	73,5	2,89	48,5	1,91	54	2,13	24	0,95	44	1,73	64	2,52	49,9	1,97	10	0,39
CC 1000 - 038 - A	1060	2383	M 48 X 2	38	1,50	99,5	3,92	61,5	2,42	54	2,13	24	0,95	44	1,73	64	2,52	49,9	1,97	10	0,39
CC 1000 - 050 - A	1060	2383	M 48 X 2	50	1,97	123,5	4,86	73,5	2,89	54	2,13	24	0,95	44	1,73	64	2,52	49,9	1,97	10	0,39
CC 1000 - 075 - A	1060	2383	M 48 X 2	75	2,95	173,5	6,83	98,5	3,88	54	2,13	24	0,95	44	1,73	64	2,52	49,9	1,97	10	0,39
CC 1000 - 100 - A	1060	2383	M 48 X 2	100	3,94	223,5	8,80	123,5	4,86	54	2,13	24	0,95	44	1,73	64	2,52	49,9	1,97	10	0,39
CC 1000 - 150 - A	1060	2383	M 48 X 2	150	5,91	323,5	12,74	173,5	6,83	54	2,13	24	0,95	44	1,73	64	2,52	49,9	1,97	10	0,39

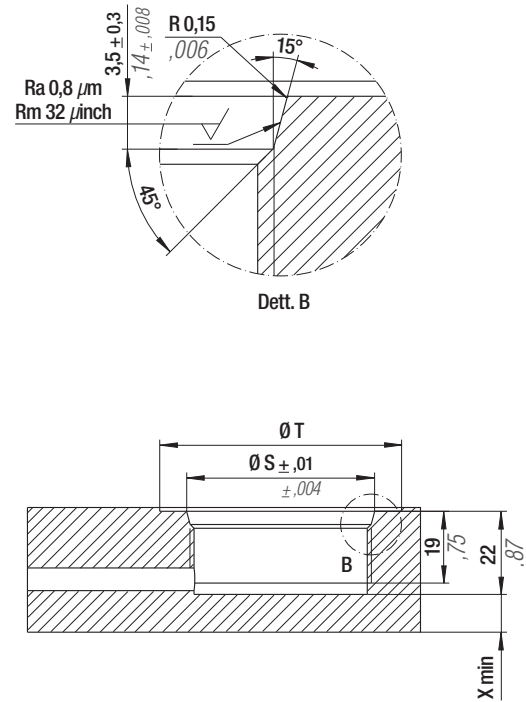
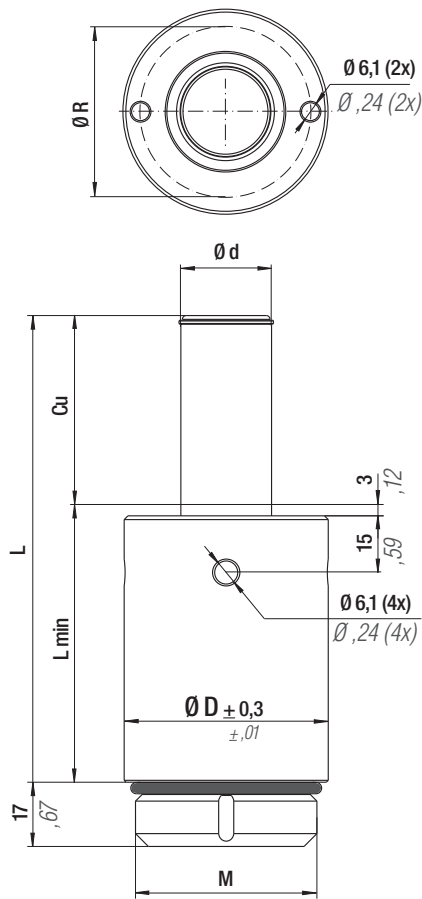

MODEL	Fo		M	Cu		L		L min		$\emptyset D$		$\emptyset d$		$\emptyset R$		$\emptyset T$		$\emptyset S$		Xmin	
	daN	lb		mm	inch	mm	inch	mm	inch	mm	inch	mm	inch	mm	inch	mm	inch	mm	inch	mm	inch
CC 2500 - 025 - A	2520	5665	M 64 X 2	25	0.98	73,5	2.89	48,5	1.91	70	2.76	30	1.18	58	2.28	80	3.15	65,9	2.59	10	0.39
CC 2500 - 038 - A	2520	5665	M 64 X 2	38	1.50	99,5	3.92	61,5	2.42	70	2.76	30	1.18	58	2.28	80	3.15	65,9	2.59	10	0.39
CC 2500 - 050 - A	2520	5665	M 64 X 2	50	1.97	123,5	4.86	73,5	2.89	70	2.76	30	1.18	58	2.28	80	3.15	65,9	2.59	10	0.39
CC 2500 - 075 - A	2520	5665	M 64 X 2	75	2.95	173,5	6.83	98,5	3.88	70	2.76	30	1.18	58	2.28	80	3.15	65,9	2.59	10	0.39
CC 2500 - 100 - A	2520	5665	M 64 X 2	100	3.94	223,5	8.80	123,5	4.86	70	2.76	30	1.18	58	2.28	80	3.15	65,9	2.59	10	0.39
CC 2500 - 150 - A	2520	5665	M 64 X 2	150	5.91	323,5	12.74	173,5	6.83	70	2.76	30	1.18	58	2.28	80	3.15	65,9	2.59	10	0.39



IT Oltre alla protezione SKUDO installata come standard sulle serie KE, RS ed MS, Special Springs offre una completa gamma di raschiatori secondari per migliorare le prestazioni dei cilindri a gas utilizzati in ambienti molto contaminati. I nuovi raschiatori secondari in poliuretano sono progettati per un perfetto fitting con i vari modelli di cilindri. Vedi le tabelle per i dati tecnici. I raschiatori secondari sono ordinabili separatamente dal cilindro e installabili dall'utilizzatore o, se richiesti al momento dell'ordine, installati direttamente in fabbrica da Special Springs.

EN In addition to the SKUDO protection, which is standard on series KE, RS and MS, Special Springs offers a complete range of secondary wipers to improve performances of nitrogen cylinders used in heavy contaminated environments. The new secondary wipers, made in polyurethane, are designed for a perfect fitting with many series of nitrogen cylinders. See the charts for technical data. The secondary wipers can be ordered separately from the cylinders. They can be assembled by user or, if requested with the order, by Special Springs.

DE Neben dem SKUDO-Schutz, der standardmäßig auf der Produktreihe KE, RS und MS installiert ist, bietet Special Springs ein komplettes Sortiment an Sekundärabstreifer zur Verbesserung der Leistungen von Gasdruckfedern, die in stark kontaminierten Umgebungen eingesetzt werden. Die neuen Sekundärabstreifer, hergestellt aus Polyurethan, sind für eine perfekte Montage mit vielen Serien von Gasdruckfedern ausgelegt. Siehe die Tabelle für technische Daten. Die Sekundärabstreifer können separat von den Gasdruckfedern bestellt und vom Anwender montiert werden oder, falls in der Bestellung gewünscht, werkseitig vormontiert von Special Springs.

FR En plus de la protection SKUDO installée en standard sur les séries KE, RS et MS, Special Springs offre une gamme complète de joints racleurs secondaires pour améliorer les performances des ressorts à gaz utilisés dans les environnements fortement contaminés. Les nouveaux joints racleurs secondaires, fabriqués en polyuréthane, sont conçus pour une parfaite fixation avec de nombreuses séries de ressorts à gaz. Voir les tableaux pour les données techniques. Les joints racleurs secondaires peuvent être commandés séparément des cylindres et assemblés par l'utilisateur ou, si demandé dans la commande, seront assemblés en usine par Special Springs.

ES Además de la protección SKUDO instalada como estándar en las series KE, RS y MS, Special Springs ofrece una gama completa de rascadores secundarios para mejorar las prestaciones de los cilindros de nitrógeno utilizados en entornos muy contaminados. Los nuevos rascadores secundarios de poliuretano están diseñados para un ajuste perfecto con muchas series de cilindros de nitrógeno. Consulte las tablas para obtener información técnica. Los rascadores secundarios se pueden pedir por separado de los cilindros y ser montados por el usuario o, si se solicita en el pedido, se montarán en la fábrica por Special Springs.

PT Além da protecção SKUDO instalada como padrão na série KE, RS e MS, Special Springs oferece uma gama completa de raspadores secundários para melhorar os desempenhos dos cilindros de nitrogênio utilizados em ambientes muito contaminados. Os novos raspadores secundários, feitos de poliuretano, são projetados para um perfeito montagem com muitas séries de cilindros de nitrogênio. Veja a guia abaixo para obter dados técnicos. Os raspadores secundários podem ser encomendados separadamente dos cilindros e montados pelo usuário ou, se solicitado com a ordem, serão montados na fábrica por Special Springs.

SECONDARY WIPER - SW

Cylinder Code	A mm	B mm	Secondary Wiper Code
M 300	2	4	59SW001
RV / RT 350	2	4	59SW002
RV / RT 500	2	4	59SW003
RV / RG / RT 750	2	4	59SW004
RV / RG / RT 1000	2	5	59SW005
RV / RT 1200	2	5	59SW005
RV / RG / RT 1500	2,5	5,5	59SW006
RV / RG / RT 2400	2,5	5,5	59SW007
RV / RG / RT 4200	2,5	5,5	59SW008
RV / RG / RT 6600	2,5	5,5	59SW009
RV / RT 9500	3	6	59SW010
RV 12000	3	6	59SW011
RV 20000	3	6	59SW012
H 300	2	4	59SW002
H 500	2	4	59SW003
H 700	2	4	59SW004
H 1000	2	5	59SW005
H 2400	2,5	5,5	59SW007
H 4200	2,5	5,5	59SW008
H 6600	2,5	5,5	59SW009
H 9500	3	6	59SW010
H 18500	3	6	59SW013

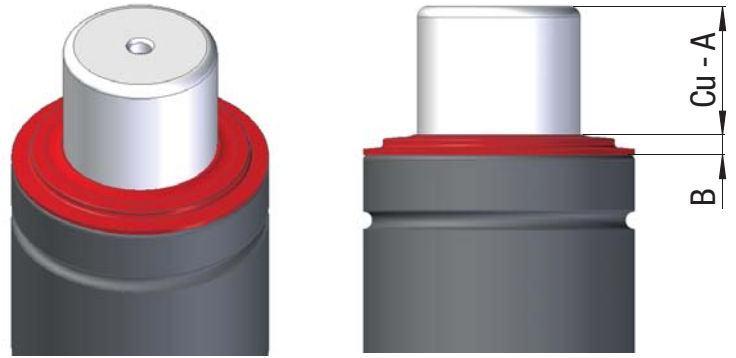

A = Nominal stroke reduction

Cu = Nominal Stroke

Cylinder Code	A mm	B mm	Secondary Wiper Code
SC 150	2	4	59SW014
SC/SCF 250	2	4	59SW015
SC 500	2	4	59SW016
S/SC 750	2,5	5,5	59SW017
SC 1500	2,5	5,5	59SW018
SC 3000	2,5	5,5	59SW019
SC 5000	3	6	59SW020
SC 7500	3	6	59SW021
SC 10000	3	6	59SW022

 The installation of the secondary wiper will require the removal of the active safety marker OSM where mounted.

Cylinder Code	A mm	B mm	Ø D mm	Secondary Wiper Code
M 50	2,5	9,5	15	59SW023
M 70	2,5	9,5	18	59SW024
M 90	2,5	10,5	22	59SW025
M 200	2,5	10,5	28	59SW026
RV 170	2,5	9,5	22	59SW027
RV 320	2,5	9,5	28	59SW028

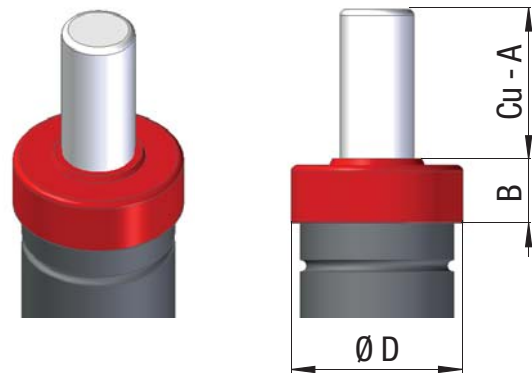

A = Nominal stroke reduction

Cu = Nominal Stroke

HOW TO ORDER



Ordering example for RV350 - ... + secondary wiper



Ordering example ONLY for secondary wiper

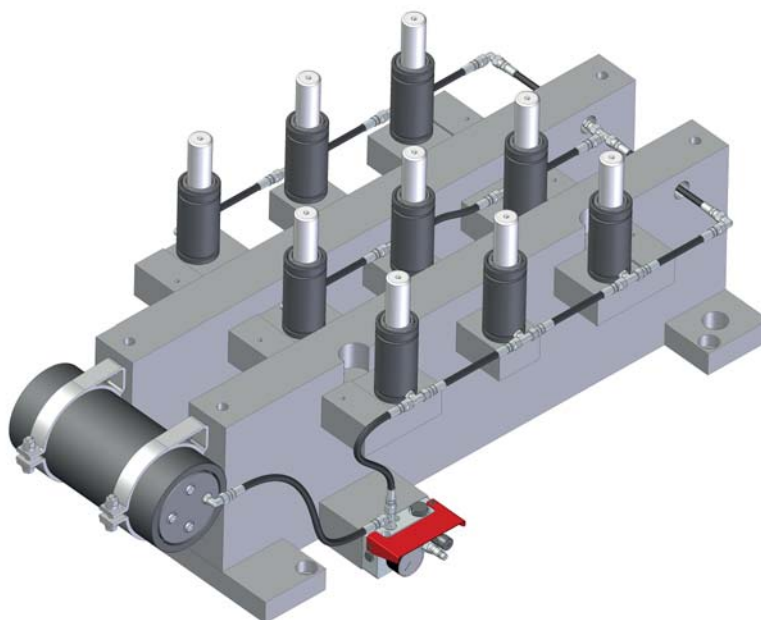

IT VANTAGGI

- Pressione uguale in tutti i cilindri
- Controllo della pressione = controllo della forza
- Aumento/riduzione della pressione = aumento/riduzione della forza attraverso il pannello di controllo anche durante lo stampaggio senza intervento diretto sui cilindri
- Utilizzo di polmoni di compensazione per un ridotto incremento della pressione a fine compressione
- Gestione di impianti e forze diverse nello stesso stampo (uso multipannello MCPC+AUMCP)
- Stop di sicurezza con uso pressostato
- Utilizzo tappo di sicurezza con disco di rottura CE
- Flessibilità di collegamento con tubi e raccordi EO - 24°, JIC 37°, Minimes, Micro 32°, ORFS



I cilindri collegabili a sistema (codice modello + N/NA) sono forniti privi di valvola unidirezionale e con corpo/fondello speciale dove previsto. Per le serie S/SC/H/KE/RV/RS/RF/RG/RT/LS è possibile trasformare i cilindri autonomi in cilindri collegabili a sistema semplicemente rimuovendo i dispositivi di tenuta dal foro di caricamento. Scaricare completamente la pressione prima di questa operazione. Qualora si rendesse necessario rimuovere uno qualsiasi dei componenti installati, scaricare completamente la pressione attraverso il pannello.

EN BENEFITS

- Same pressure in all cylinders
- Pressure control = force control
- Increase/decrease of pressure = increase/decrease of force by control panel even during stamping operation without direct acting to the cylinders
- Lower pressure increase by using compensation tank
- Possibility to manage different systems and forces in the same tool by using the multipanel MCPC+AUMCP
- Safe stop function through pressure switch
- Use of the safety plug with rupture disc CE
- Flexible linking by using hose and connection EO - 24°, JIC 37°, Minimes, Micro 32°, ORFS and couplings and many useful accessories



The hoses system cylinders (model code + N/NA) are supplied without charging valve and with special body/end plate when specified. However S/SC/H/KE/RV/RS/RF/RG/RT/LS series can be converted from self-contained to hoses system by simply removing the charging valve. Be sure that all pressure is exhausted before starting this operation. In case it's necessary to remove any of the installed components, pressure must be fully exhausted through the control panel.

DE VORTEILE

- Identischer Druck in allen Zylindern
- Druckkontrolle = Kraftkontrolle
- Steigerung/Minderung des Drucks = Erhöhung/Verringerung der Kraft über die Steuerung, auch während der Formung ohne direkten Eingriff an den Zylindern
- Einsatz von Ausgleichbehältern zur Reduzierung von Druckerhöhungen
- Verwaltung verschiedenartiger Anlagen und Leistungen in demselben Werkzeug über die Multisteuerung MCPC+AUMCP
- Sicherheitsstopp per Druckwächter
- Verwendung eines Sicherheitsverschlusses mit Berstscheibe (CE-Kennzeichnung)
- Flexibilität bei der Verbindung mit Rohren und Anschlüssen EO - 24°, JIC 37°, Minimes, Micro 32°, ORFS



Zylinder im verbund (Modellcode + N/NA) werden ohne Einwegventile und, sofern vorgesehen, mit speziellem Gehäuse/Boden geliefert. Für die Serien S/SC/H/KE/RV/RS/RF/RG/RT/LS können die autonomen arbeitenden Zylinder in Zylinder im verbund abgeändert werden, indem die Dichtungsvorrichtungen an der Luftzufuhröffnung entfernt werden. Lassen Sie die Druckluft vor diesem Arbeitsschritt komplett ab. Falls es sich als notwendig erweisen sollte, einen der installierten Komponenten zu entfernen, muss vorher die Druckluft mittels der Steuerung vollständig abgelassen werden.

FR AVANTAGES

- La même pression dans tous les ressorts
- Contrôle de la pression = contrôle de la force
- Augmentation/réduction de la pression = augmentation/réduction de la force par l'intermédiaire du panneau de contrôle, même durant le moulage, sans aucune intervention directe sur les ressorts
- Utilisation de réservoirs de compensation produisant une petite augmentation de la pression à la fin de la compression

- Gestion d'installations et de forces différentes sur le même outil (utilisation multi-panneaux MCPC+AUMCP)
- Arrêt de sécurité à l'aide d'un pressostat
- Utilisation d'un bouchon de sécurité avec disque de rupture CE
- Souplesse du raccordement à l'aide de tubes et de raccords EO - 24°, JIC 37°, Minimes, Micro 32°, ORFS



Les ressorts pouvant être reliés à un système (référence modèle + N/NA) sont livrés sans la vanne unidirectionnelle et avec corps/fond spécial si prévu. Pour les séries S/SC/H/KE/RV/RS/RF/RG/RT/LS, il est possible de transformer les ressorts autonomes en cylindres pouvant être reliés à un système en ôtant simplement les dispositifs d'étanchéité du trou de chargement. Décharger complètement la pression avant d'effectuer cette opération. S'il est nécessaire de démonter un des composants installés, décharger complètement la pression par l'intermédiaire du panneau de contrôle.

ES VENTAJAS

- La misma presión en todos los cilindros
- Control de la presión = control de la fuerza
- Aumento/reducción de la presión=aumento/reducción de la fuerza mediante el panel de control incluso en operaciones de estampación sin actuación directa sobre los cilindros
- Pueden emplearse pulmones de compensación para reducir el aumento de la presión al final de la compresión

- Gestión de equipos y fuerzas distintas sobre el mismo molde (uso multipanel MCPC+AUMCP)
- Parada de emergencia con presostato
- Tapón de seguridad con disco de ruptura CE
- Flexibilidad de conexión con tubos y acoplamientos EO - 24°, JIC 37°, Minimes, Micro 32°, ORFS



Los cilindros para su conexión en sistema (código modelo + N/NA) se sirven sin válvula unidireccional y con cuerpo/base especiales en los casos en que se requieran. En las series S/SC/H/KE/RV/RS/RF/RG/RT/LS, los cilindros autónomos pueden transformarse en cilindros para su conexión en sistema simplemente quitando los dispositivos de estanqueidad del orificio de carga. Antes de realizar esta operación, vaciar completamente la presión. Si fuera necesario quitar alguno de los componentes instalados, vaciar completamente la presión mediante el panel de control.

PT VANTAGENS

- Pressão igual em todos os cilindros
- Controlo da pressão = controlo da força
- Aumento/redução da pressão=aumento/redução da força através do painel de controlo também durante a estampagem sem intervenção directa sobre os cilindros
- Utilização dos tanques de compensação para redução do aumento da pressão no final da compressão

- Gestão de instalações e de várias forças na mesma Ferramenta (uso do multi-painel MCPC+AUMCP)
- Stop de segurança com utilização do pressostato
- Utilização de Bujão de segurança com disco de rotura CE
- Flexibilidade de ligação com tubos e ligações EO - 24°, JIC 37°, Minimes, Micro 32°, ORFS



Os cilindros ligáveis em sistema (código do modelo + N/NA) são fornecidos sem válvula unidireccional e com corpo/extremidade especial. Para a série S/SC/H/KE/RV/RS/RF/RG/RT/LS, é possível transformar os cilindros autónomos em cilindros ligáveis em sistema, bastando remover os dispositivos de retenção do orificio de carga. Descarregar completamente a pressão antes desta operação. No caso de ser necessário remover um dos componentes instalados, descarregar completamente a pressão através do painel de controlo.

RIGHT

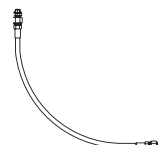
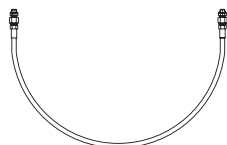

WRONG

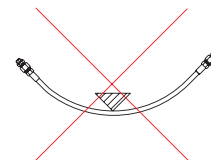
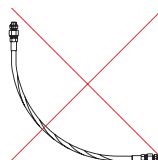
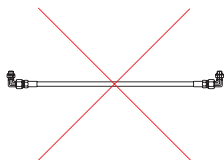
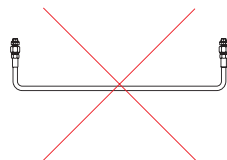

LINKED SYSTEM SELECTION

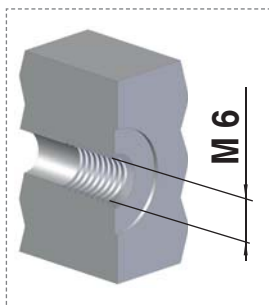

MINIMESS - CONNECTIONS
S12,65x1,5

TM

Low gas flow

MICRO - CONNECTIONS
M8x1

Twin seal

TSM

Low gas flow

JIC 37° - CONNECTIONS
7/16"-20 UNF

TNC

High gas flow

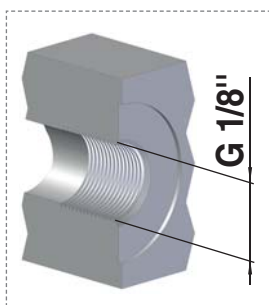

ORFS - CONNECTIONS
9/16"-18 UNF

HY 400

High gas flow

EO - 24° - CONNECTIONS
M12x1,5

Twin seal

HY 500

High gas flow

IT

- Pressa trasportabile con pompa pneumatica
- Idonea per raccordi dritti, 45° e 90°

EN

- Transportable press with hydraulic manual pump
- Suitable for straight, 45° and 90° fittings

DE

- Transportable Presse mit manueller Hydraulikpumpe
- Geeignet für gerade, 45° und 90° Anschlüsse

FR

- Presse transportable avec pompe oléodynamique manuelle
- Utilisable avec raccords droits, 45° et 90°

ES

- Prensa transportable con bomba oleodinámica manual
- Puede ser utilizada con tuberías derechas, 45° y 90°

PT

- Prensa transportável com bomba hidráulica manual
- Pode ser usado com tubos retos, 45° e 90°

code 39PR06A



code 58UT022A (included)



IT Utensile rimuovi morsetti con calamita

EN Magnet tool to remove pressing jaws

DE Magnetwerkzeug für die Entfernung von Pressbacken

FR Outil magnétique pour enlever les mâchoires de pressage

ES Herramienta magnética para la remoción de las mordazas de prensado

PT Ferramenta magnética para remover os mordentes de prensar

code 58UT001A (optional)



IT Forbice taglia tubo

EN Scissor for hose

DE Schlauchschneideschere

FR Ciseaux coupe-tube

ES Tijeras cortatubos

PT Tesouras corta tubos

code 58UT023A (optional)



IT Lampada led con magnete

EN LED Light with magnet

DE LED-Lampe mit Magnet

FR Lampe à LED magnétique

ES Lámpara LED con imán

PT Lâmpada LED com íman

AIR	7 bar 110 psi	100 TON 110 US TON	380 x 430 x 400 mm 15 x 17 x 16 inch	38 kg 84 lb
				-5 ÷ 40 °C 23 ÷ 104 °F

CONNECTIONS	ORFS "TSM" HOSE Ø 5,5 p. 248	Micro 32° - JIC 37° "TSM" HOSE Ø 5,5 p. 238 - 242	Minimess "TM" HOSE Ø 5,1 p. 240	JIC 37° "TNC" HOSE Ø 8,1 p. 238	EO 24° "HY 500" HOSE Ø 11 p. 234	ORFS "HY 400" HOSE Ø 12,7 p. 246
PRESSING JAWS	code 39MTR10 (optional) 	code 39MTR11 (optional) 	code 39MTR12 (optional) 	code 39MTR13 (optional) 		

Ordering example: **39PR06A + 39MTR11** | Pressing jaws for Jic 37° "TNC" HOSE Ø 8,1

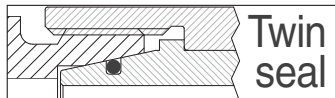

code 36HY50001...

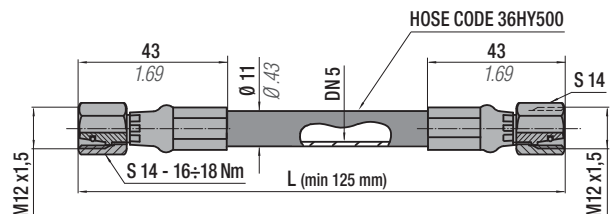

code 36HY50002...

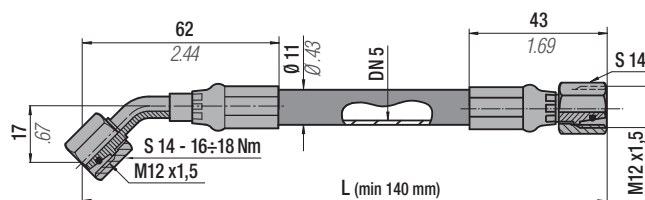

code 36HY50003...

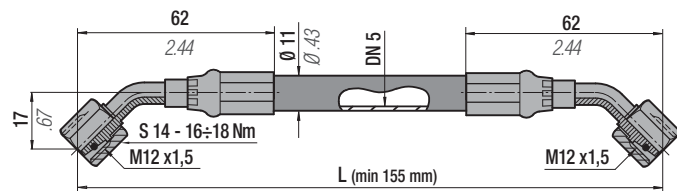

code 36HY50004...

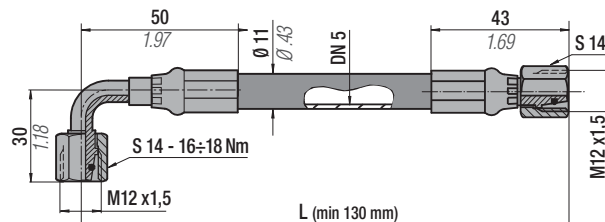

code 36HY50005...

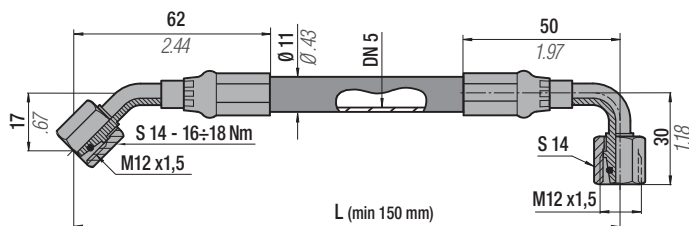

code 36HY50006...

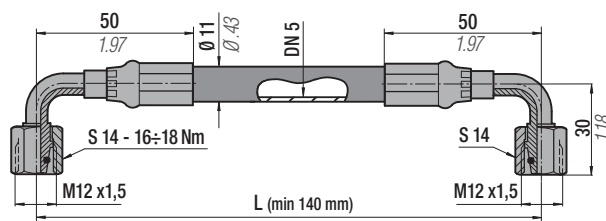

Technical data

"L" min	See above	-	Volume	18 ml/metre
Operation pressure	345 bar	5003 psi	Dimension	3/16" (external Ø 11 mm)
Burst Pressure	1380 bar at 20°C	20010 psi at 68°F	Material	Thermoplastic
R (bending radius)	40 mm	1.57 in	Standard	SAE 100R8
Operation temperature	-40+ 100°C	-38+212°F	Outer casing	Perforated



Lunghezza richiesta comprensiva di raccordi terminali
Length upon request including end hose fittings
Länge Anfrage einschließlich Ende Schlaucharmaturen

Longueur requise, y compris des raccords d'extrémité
Longitud requerida, incluyendo accesorios de los extremos
Comprimento necessário incluindo todos os acessórios

code: 36FF11A

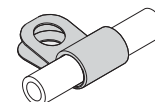
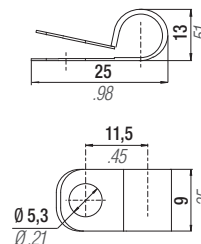

standard L = 120 mm min. - 5 mm upword increase - Example (36HY50001 0300; 36HY50001 0305; ...)

HOSE FITTINGS

code 36P2401

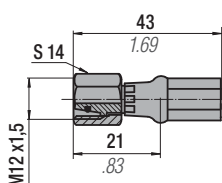

code 36P2402

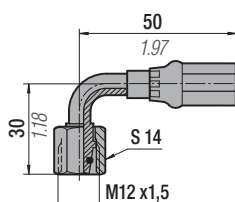

code 36P2403

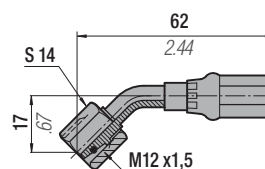

Raccordi tubo-cilindro/pannello - Hose-cylinder/panel connections - Anschlüsse zwischen schlauch und Zylinder/Kontrollarmatur -
 Raccords tuyau-cylindre/tableau - Conexiones sistema de cilindros/panel - Racord tubo-cilindro/painel

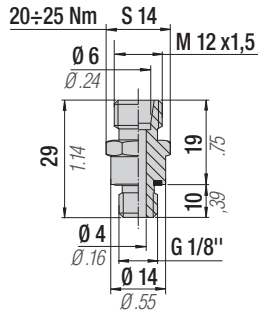
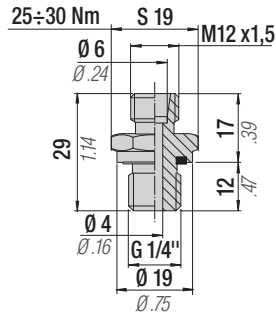
code 36R2401

code 36R2402

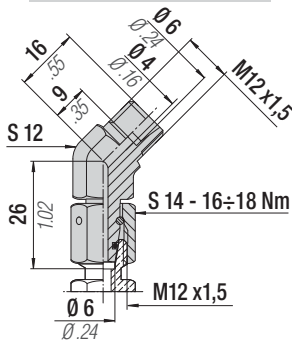
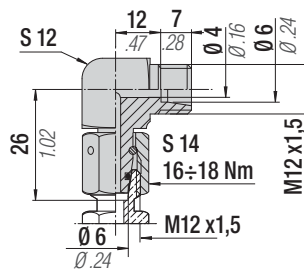
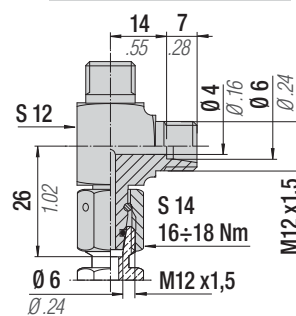
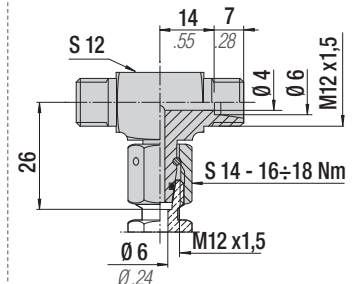
Raccordi di derivazione - Offtake connections - Anschlußstutzen - Raccords de dérivation - Racores - Racord de derivação

code 36R2403

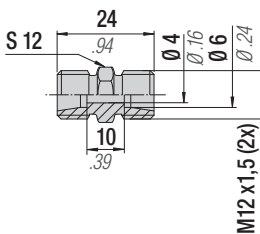
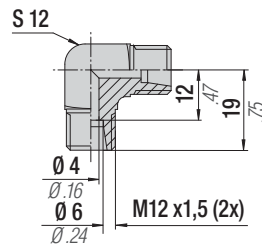
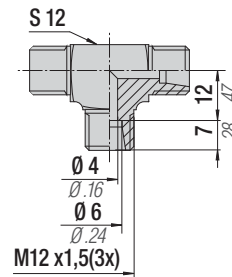
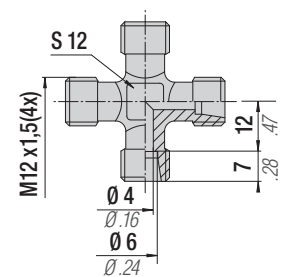
code 36R2404

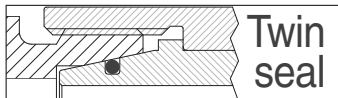
code 36R2405

code 36R2406

Raccordi tubo-tubo - Hose-hose connections - Anschlüsse zwischen Schlauch und Schlauch - Raccords tuyau-tuyau - Conexiones de tubo a tubo - Racord tubo-tubo

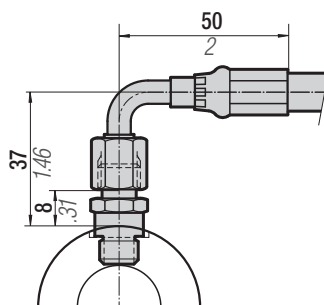
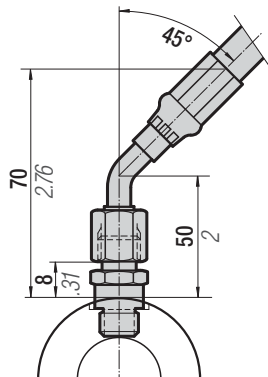
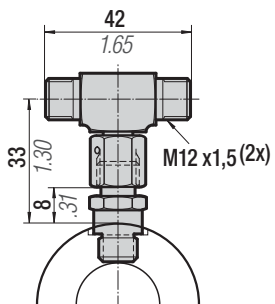
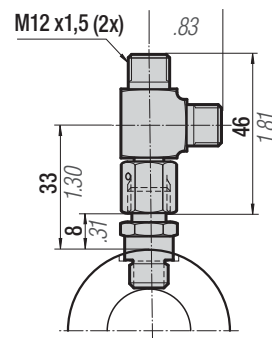
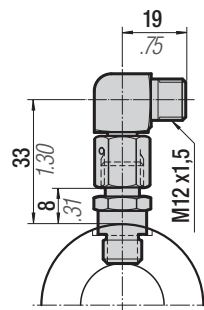
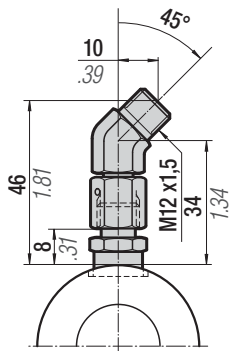
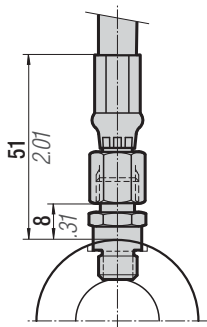
code 36R2407

code 36R2408

code 36R2409

code 36R2410



Esempi di installazione - Installation examples - Einbaubeispiele - Exemples de montage - Ejemplos de instalación - Exemplos de instalação





THIS PAGE IS INTENTIONALLY LEFT BLANK

code TNC 7/16...

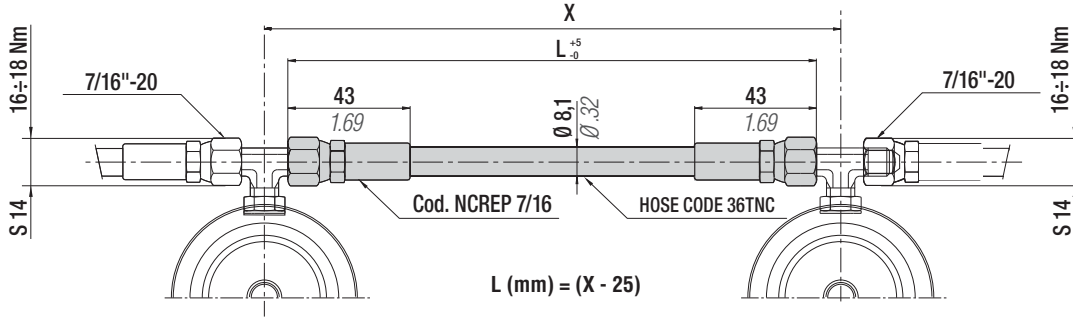

Technical data				
"L" min	140 mm	5.51 in	Volume	12,6 ml/metre
Operation pressure	420 bar	6090 psi	Dimension	1/8" (external ø 8,1 mm)
Burst Pressure	1680 bar at 20°C	24360 psi at 68°F	Material	Thermoplastic
R (bending radius)	25 mm	0.98 in	Standard	SAE 100R8
Operation temperature	-40+ 100°C	-38 +212°F	Outer casing	Perforated



Lunghezze standard (mm) inclusive di n. 2 raccordi NCREP 7/16
Standard lengths (mm) inclusive of no. 2 connections NCREP 7/16
Standard-Länge (mm) einsch. 2 NCREP 7/16 - Anschlüssen

Longueur standard (mm) comprenant 2 raccords NCREP 7/16
Longitud estándar (mm) con 2 racores incluidos NCREP 7/16
Comprimento standard (mm) incluído nas 2 ligações NCREP 7/16

standard L = 140 mm min. - 5 mm upword increase - Example (TNC 7/16 140 mm; TNC 7/16 145 mm ...)

code: 36FF09A

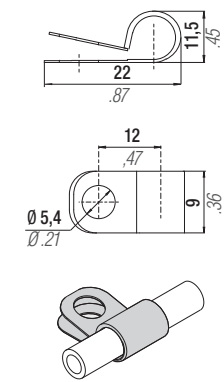

code TSM7/16...

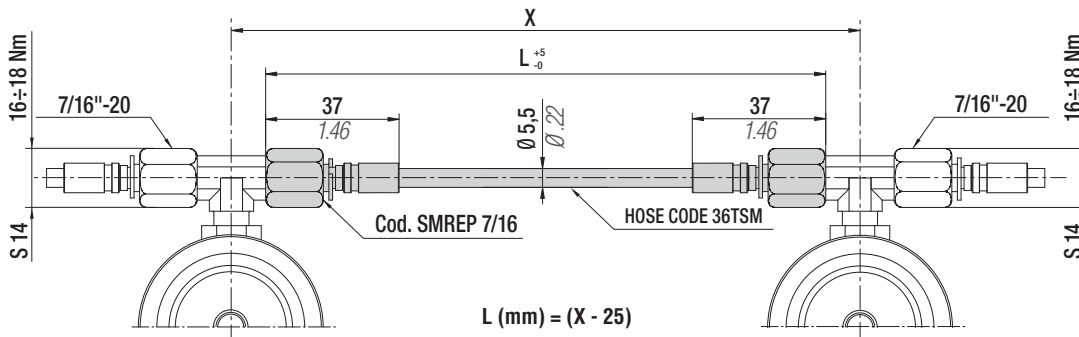

Technical data				
"L" min	90 mm	3.54 in	Volume	3 ml/metre
Operation pressure	630 bar	9135 psi	Dimension	5/64" (external ø 5,5 mm)
Burst Pressure	1890 bar at 20°C	27400 psi at 68°F	Material	Thermoplastic
R (bending radius)	20 mm	0.79 in	Standard	-
Operation temperature	-40+ 100°C	-38 +212°F	Outer casing	Perforated



Lunghezze standard (mm) inclusive di n. 2 raccordi SMREP 7/16
Standard lengths (mm) inclusive of no. 2 connections SMREP 7/16
Standard-Länge (mm) einsch. 2 SMREP 7/16 - Anschlüssen

Longueur standard (mm) comprenant 2 raccords SMREP 7/16
Longitud estándar (mm) con 2 racores incluidos SMREP 7/16
Comprimento standard (mm) incluído nas 2 ligações SMREP 7/16

standard L = 90 mm min. - 10 mm upword increase - Example (TSM 7/16 90 mm; TSM 7/16 100 mm ...)

code: 36FF06A

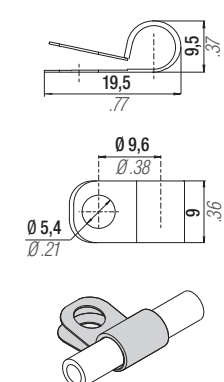

Raccordi tubo-cilindro/pannello - Hose-cylinder/panel connections - Anschlüsse zwischen schlauch und Zylinder/Kontrollarmatur -
Raccords tuyau-cylindre/tableau - Conexiones sistema de cilindros/panel - Racord tubo-cilindro/panel

code RTC-D

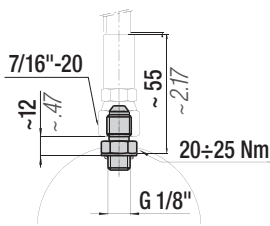

code RTC-M

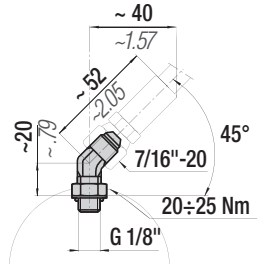

code RTC-R

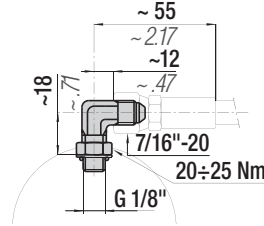

code RTC-L

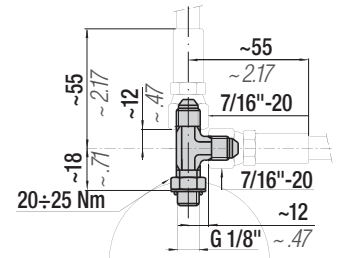

code RTC-T

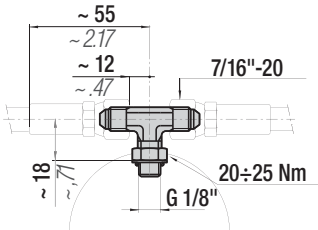

code 36J01A

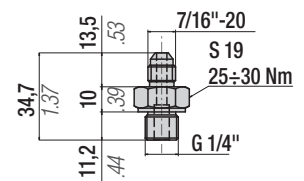

Raccordi di derivazione - Offtake connections - Anschlußstutzen - Raccords de dérivation - Racores - Racord de derivação

code RDR

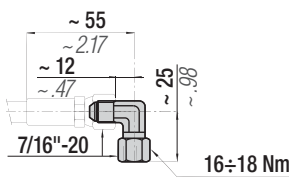

code RDT

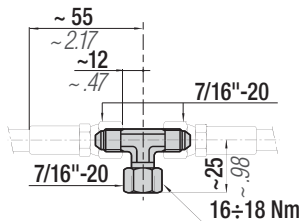

code RDM

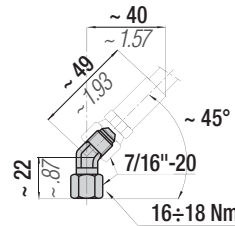

code RDL

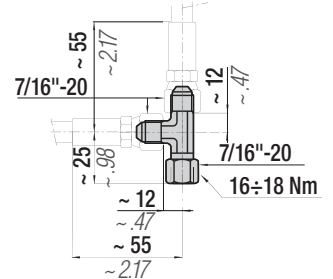

Raccordi tubo-tubo - Hose-hose connections - Anschlüsse zwischen Schlauch und Schlauch - Raccords tuyau-tuyau - Conexiones de tubo a tubo - Racord tubo-tubo

code RTT-D

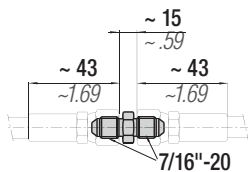

code RTT-R

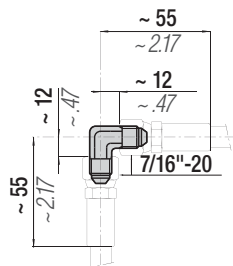

code RTT-T

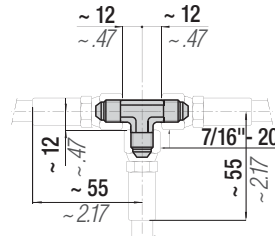

code RTT-C

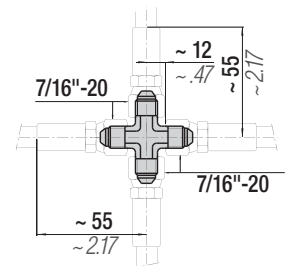

⚠ Available ONLY for loose supply

**JIC 37°
Hose Ø 8 mm**

TNB

PARKER made

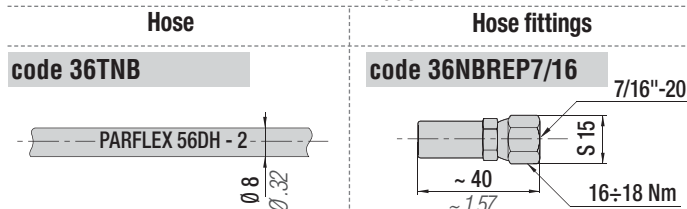

Technical data		
"L" min	140 mm	5.51 in
Operation pressure	415 bar	6017 psi
Burst Pressure	1655 bar at 20°C	24000 psi at 68°F
R (bending radius)	13 mm	0.51 in
Operation temperature	-40+ 100°C	-38+212°F

All dimensions in mm/inch



code TM...

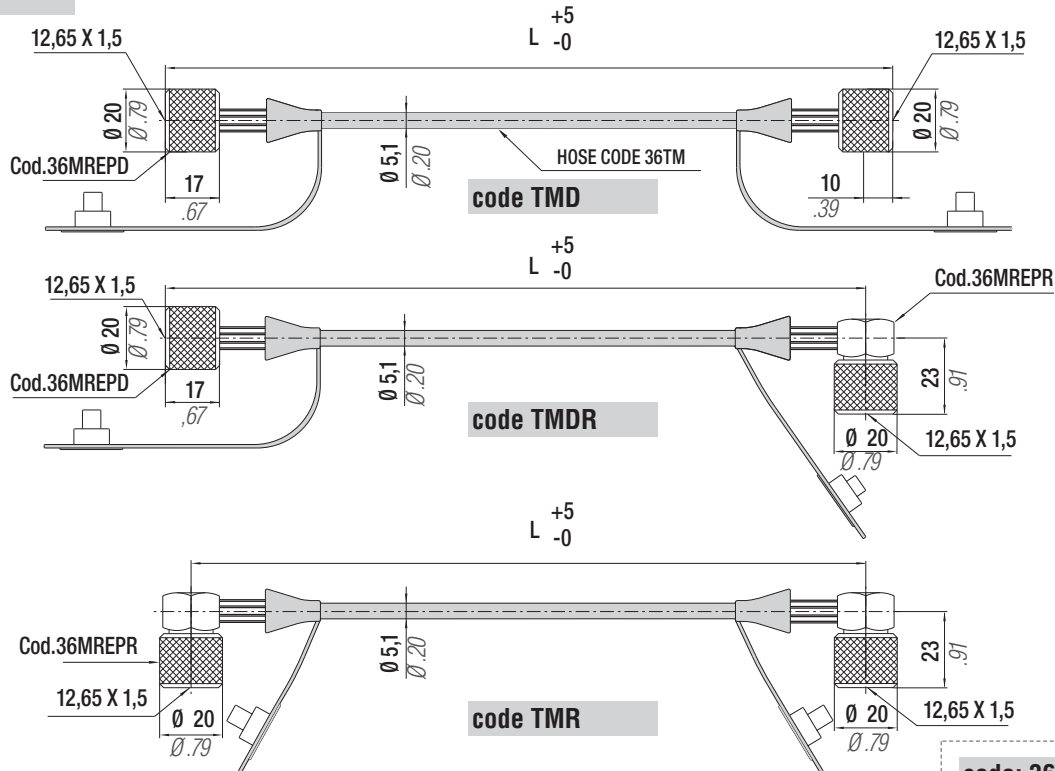

Technical data					
"L" min (TMD)	90 mm	3.54 in	Operation temp.	-20 +100°C	-2 +212°F
"L" min (TMDR-TMR)	105 mm	4.13 in	Dimension	5/64" (external Ø 5,1 mm)	
Operation pressure	630 bar	9135 psi	Material	Polyamid	
Burst Pressure	1950 bar at 20°C	28275 psi at 68°F	Standard	-	
R (bending radius)	20 mm	0.79 in	Outer casing	Perforated	

code: 36FF06A

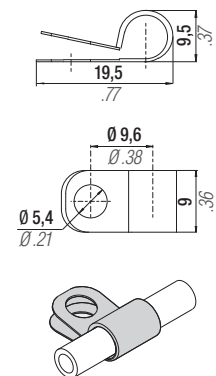

Lunghezza standard (mm) inclusive di n. 2 raccordi MREP D / R
Standard lengths (mm) inclusive of no. 2 connections MREP D / R
Standard-Länge (mm) einsch. 2 MREP D / R - Anschlüssen

Longueur standard (mm) comprenant 2 raccords MREP D / R
Longitud estándar (mm) con 2 racores incluidos MREP D / R
Comprimento standard (mm) incluido nas 2 ligações MREP D / R

standard L = 90 mm min. - 10 mm upword increase - Example (TM... 90 mm; TM... 100 mm ...)

CONNECTIONS MINIMESS

code RM...

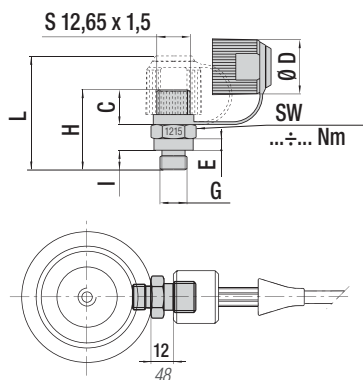

Technical data								
code RM...	G	I	H	L	SW	C	Ø D	E
RMT C ¹⁾	G 1/8"	8	30	41	14	12	19,5	4
		0.31	1.18	1.61	20±25 Nm	0.47	0.77	0.16
RMT C01 ¹⁾	G 1/4"	10	31	39	19	12	17	3
		0.39	1.22	1.54	25±30 Nm	0.47	0.67	0.12
RMT C02 ²⁾	G 1/8"	8	30	-	14	12	-	4
		0.31	1.18	-	20±25 Nm	0.47	-	0.16
RMT C03 ²⁾	G 1/4"	10	31	-	19	12	-	3
		0.39	1.22	-	25±30 Nm	0.47	-	0.12
RMPT ¹⁾	7/16-20	9	30	43	17	12	19,5	3
		0.35	1.18	1.69	20±25 Nm	0.47	0.77	0.12



- 1) Con valvola unidirezionale - With one way valve - Mit Rückschlagventil
Avec valve unidirectionnelle - Con válvula unidireccional - Com válvula unidireccional
- 2) Senza valvola unidirezionale - Without one way valve - Ohne Rückschlagventil
Sans valve unidirectionnelle - Sin válvula unidireccional - Sem válvula unidireccional

All dimensions in mm/inch

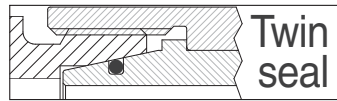

code TSM8...

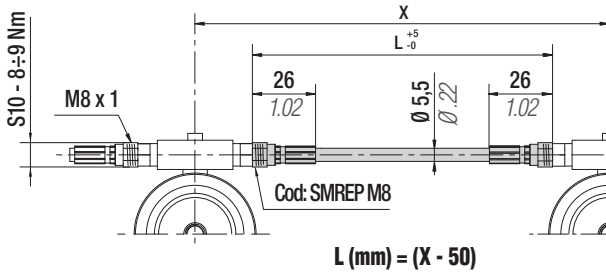

standard **L = 90 mm min. - 10 mm upword increase**
Example (TSM8 090 mm; TSM8 100 mm ...)

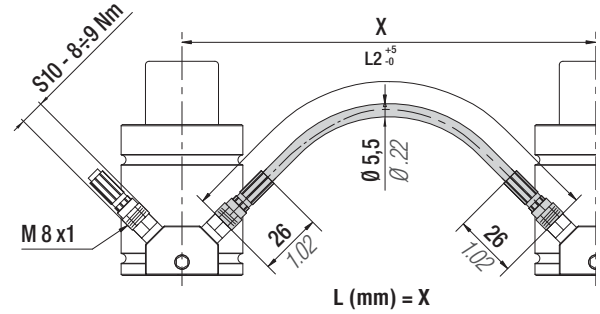

standard **L = 190 mm min. - 10 mm upword increase**
Example (TSM8 190 mm; TSM8 200 mm ...)

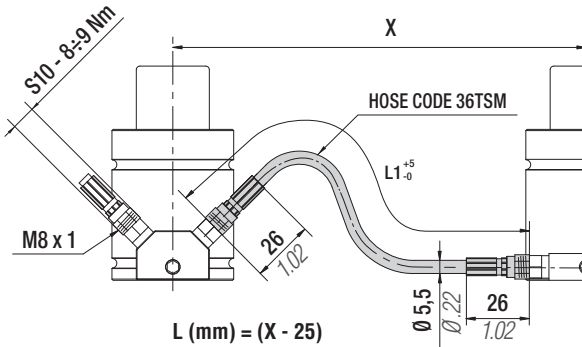

standard **L = 170 mm min. - 10 mm upword increase**
Example (TSM8 170 mm; TSM8 180 mm ...)

code: 36FF06A

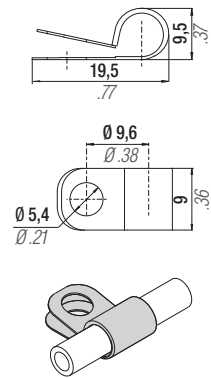

Technical data					
"L" min	90 mm	3.54 in	Operation temp.	-40 +100°C	-38 +212°F
"L1" min	170 mm	6.69 in	Volume	3 ml/metre	
"L2" min	190 mm	7.48 in	Dimension	5/64" (external Ø 5,5 mm)	
Operation pressure	630 bar	9135 psi	Material	Thermoplastic	
Burst Pressure	1890 bar at 20°C	27400 psi at 68°F	Standard	-	
R (bending radius)	20 mm	0.79 in	Outer casing	Perforated	



Lunghezze standard (mm) inclusive di n.2 raccordi SMREP M8
Standard lengths (mm) inclusive of no. 2 connections SMREP M8
Standard-Länge (mm) einsch. 2 SMREP-Anschlüssen M8

Longueur standard (mm) comprenant 2 raccords SMREP M8
Longitud estándar (mm) con 2 racores incluidos SMREP M8
Comprimento standard (mm) incluído nas 2 ligações SMREP M8

TSM **MICRO 32° and JIC 37°
Hose Ø 5,5 mm**

code TSM01A...

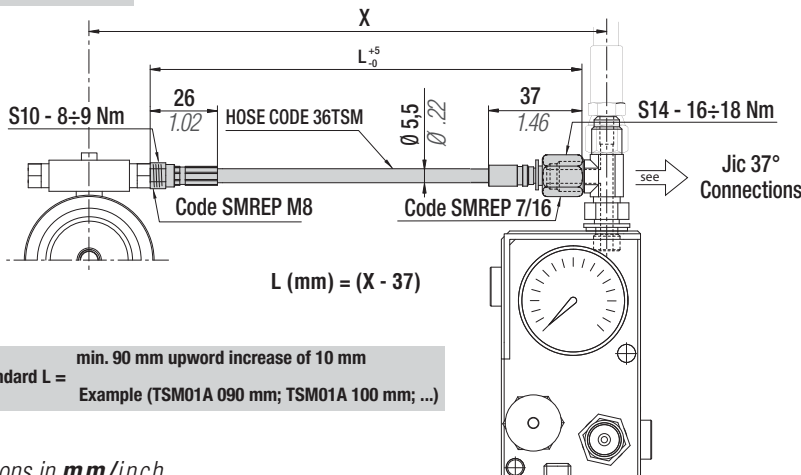

min. 90 mm upword increase of 10 mm
standard L =
Example (TSM01A 090 mm; TSM01A 100 mm; ...)

code: 36FF06A

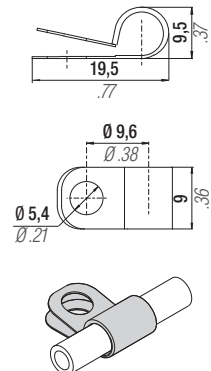

code 36TM01A...

code: 36FF06A

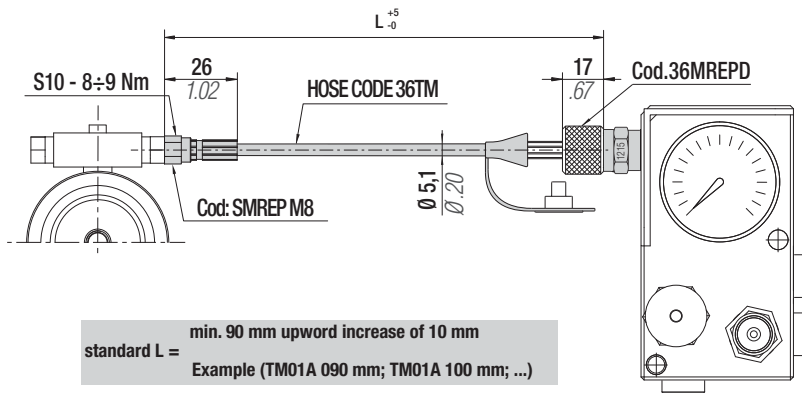
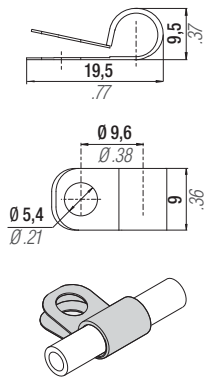

standard L = min. 90 mm upward increase of 10 mm
Example (TM01A 090 mm; TM01A 100 mm; ...)

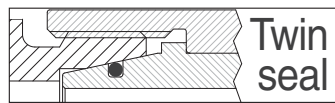

MICRO 32° CONNECTIONS

Blocchetto tubo-cilindro - Hose-cylinder block - Block, bestehend aus Schlauch-Zylinder - Bloc tube- cylindre - Bloque tubo-cilindro - Bloqueio do tubo-cilindro

code BDSM01

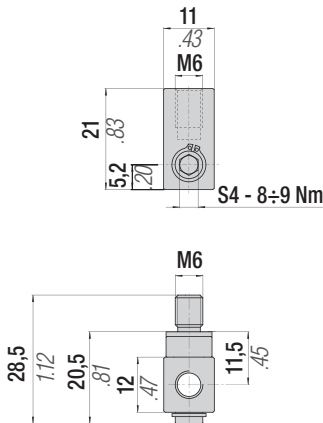

code BDSM02

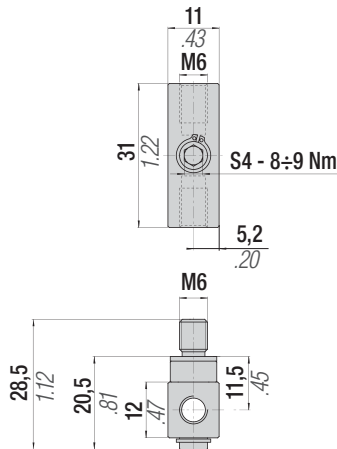

code BDSM02-45

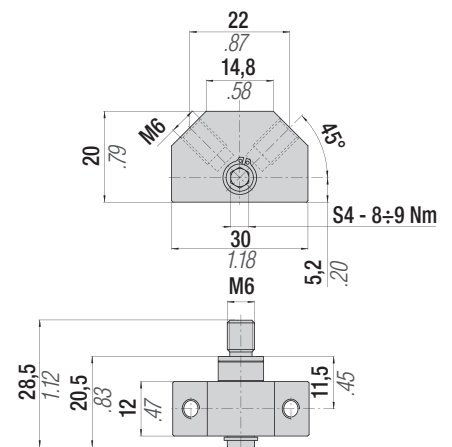

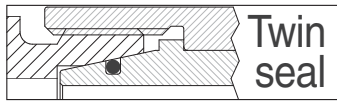

Raccordi tubo-cilindro/pannello - Hose-cylinder/panel connections - Anschlüsse zwischen schlauch und Zylinder/Kontrollarmatur - Raccords tuyau-cylindre/tableau - Conexiones sistema de cilindros/panel - Racord tubo-cilindro/painel

code MT

(only M 50, M70, M90, M90 TBM, M90 TEM, M90 TBI, M200 RV 170 - 320 rev.B)

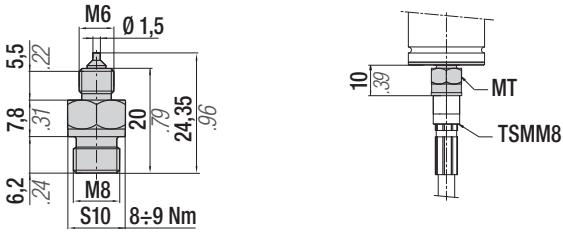

code MB

(only M 50, M70, M90, M90 TBM, M90 TEM, M90 TBI, M200 RV 170 - 320 rev.B)

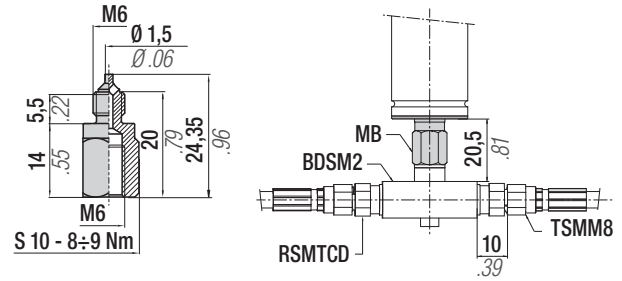

code RSMTCD

S 10 - 8±9 Nm

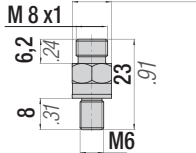

code 36M08A

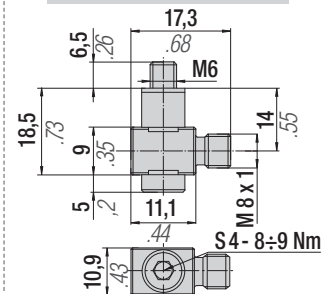

code 36M09A

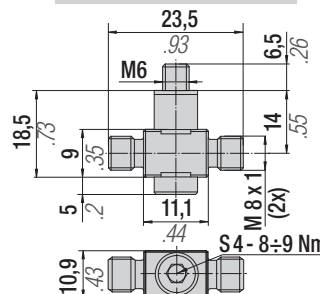

code 36M10B

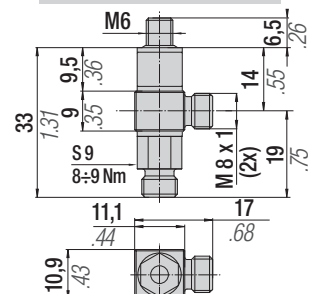

code 36M11B

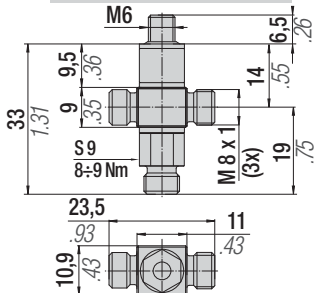

code RSMPD

S 14 - 20±25 Nm

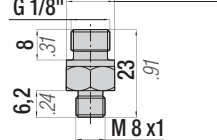

code 36M03A

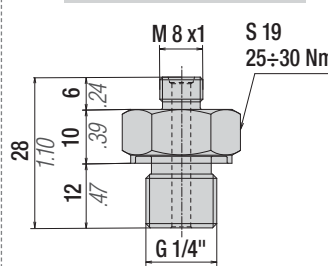

Raccordi di derivazione - Offtake connections - Anschlußstutzen - Raccords de dérivation - Racores - Racord de derivação

code 36M02A

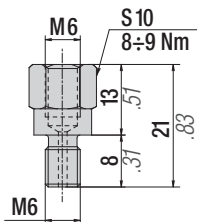

code 36M04A

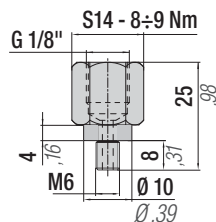

code 36MTC

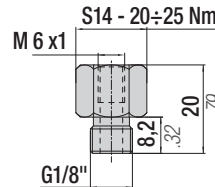

code 36MTR

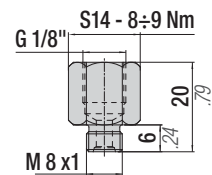

code 36M01A

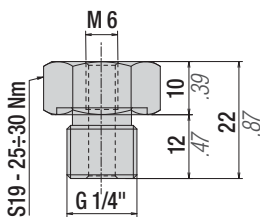

code 36M12A

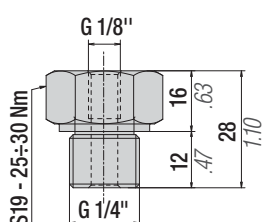

All dimensions in mm/inch

Raccordi tubo-tubo - Hose-hose connections - Anschlüsse zwischen Schlauch und Schlauch - Raccords tuyau-tuyau - Conexiones de tubo a tubo - Racord tubo-tubo

code 36MTTD

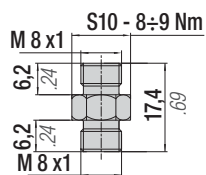

code 36RTTJM

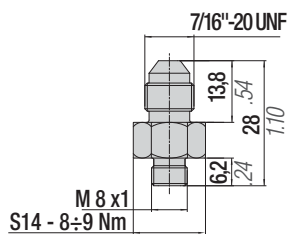

code 36M05A

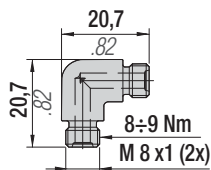

code 36M06A

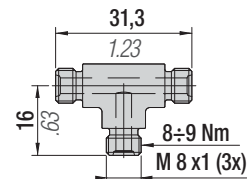

code 36M07A

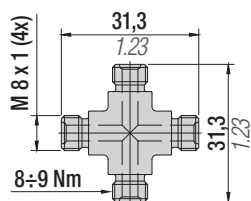

code 36HY40016...

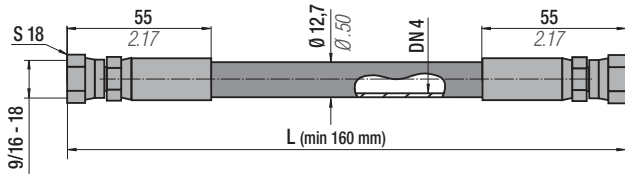

code 36HY40017...

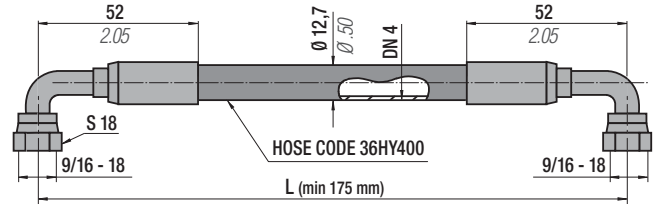

code 36HY40018...

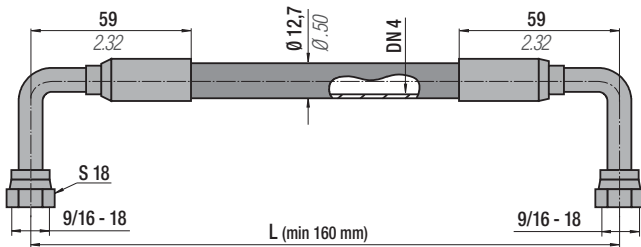

code 36HY40019...

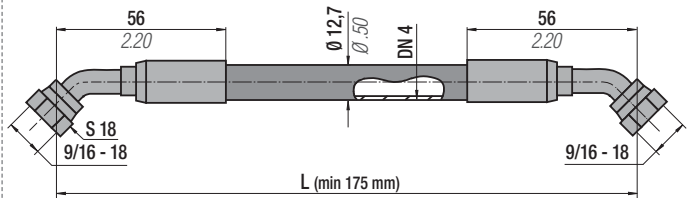

code 36HY40020...

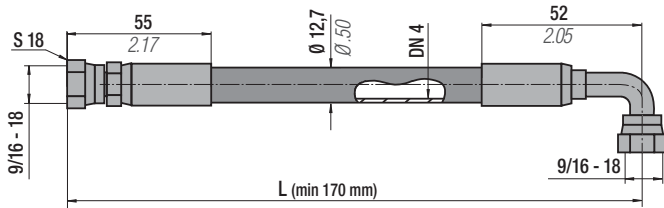

code 36HY40021...

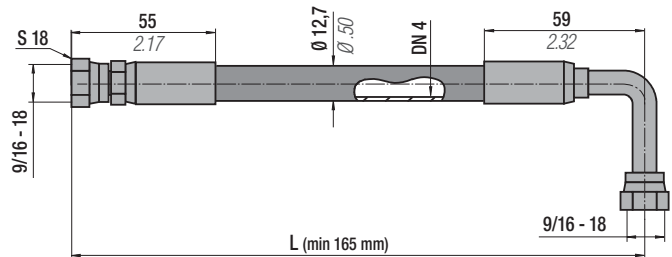

code 36HY40022...

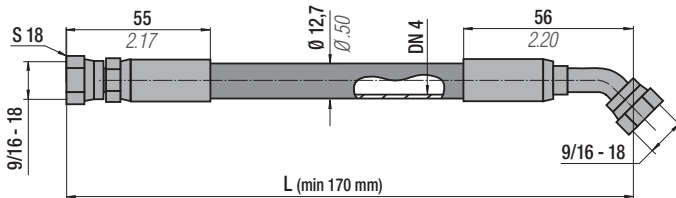

code 36HY40023...

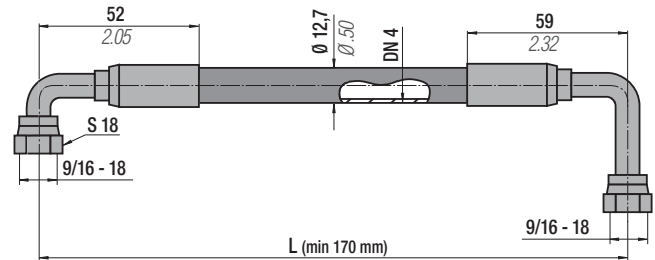

code 36HY40024...

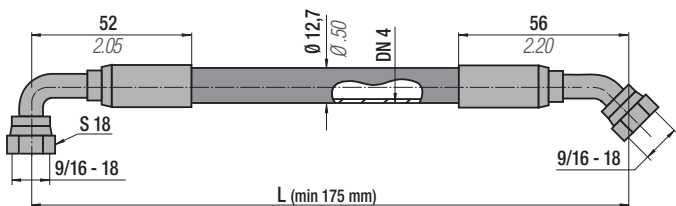

code 36HY40025...

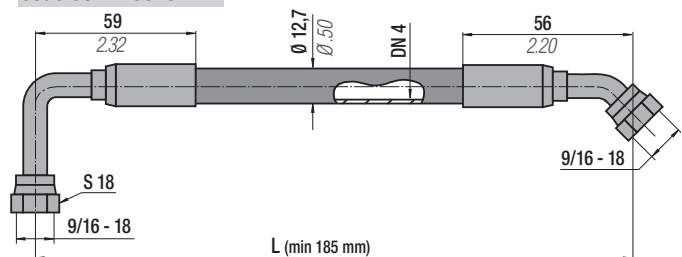

code 36HY40026...

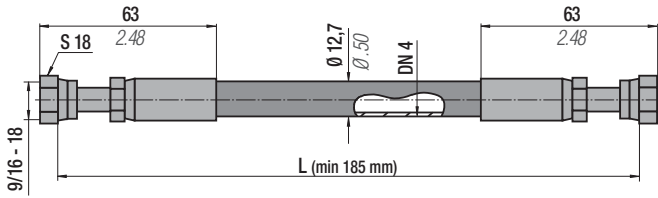

code 36HY40027...

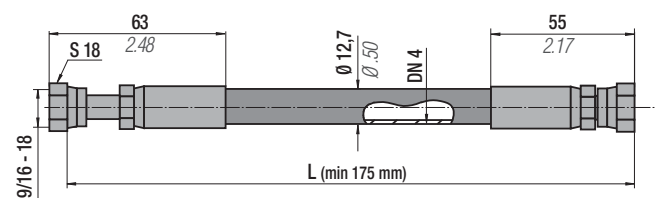

code 36HY40028...

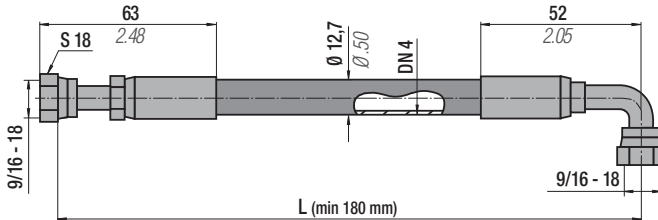

code 36HY40029...

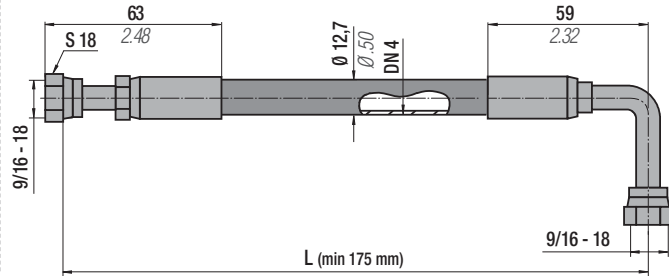

code 36HY40030...

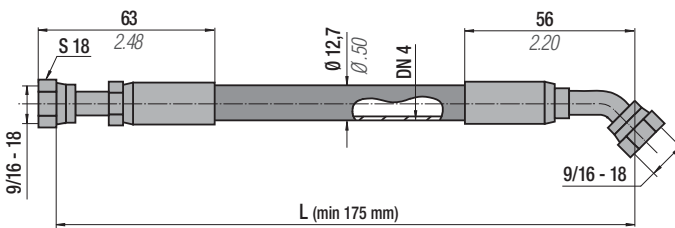

code: 36FF13A

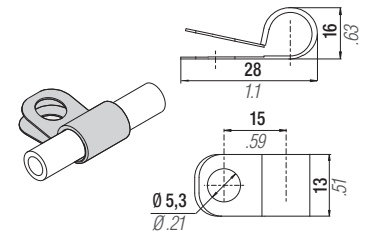

Technical data

"L" min	See above	-	Volume	32 ml/metre
Operation pressure	345 bar	5003 psi	Dimension	1/4" (external \varnothing 12,7 mm)
Burst Pressure	1380 bar at 20°C	20010 psi at 68°F	Material	Thermoplastic
R (bending radius)	51 mm	2.01 in	Standard	SAE 100R8
Operation temperature	-40+ 100°C	-38 +212°F	Outer casing	Perforated



Lunghezza richiesta comprensiva di raccordi terminali
 Length upon request including end hose fittings
 Länge Anfrage einschließlich Ende Schlaucharmaturen
 Longueur requise, y compris des raccords d'extrémité
 Longitud requerida, incluyendo accesorios de los extremos
 Comprimento necessário incluindo todos os acessórios

standard L = 255 mm min. - 5 mm upward increase - Example (36HY40016 0300; 36HY40016 0305; ...)

HOSE FITTINGS

code 36P9/1604

■ Straight Swivel

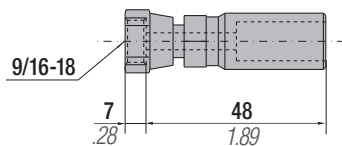

code 36P9/1605

■ Straight Long Swivel

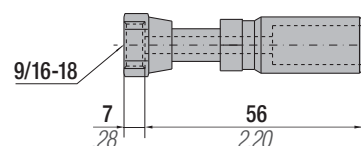

code 36P9/1606

■ 90° Long Swivel

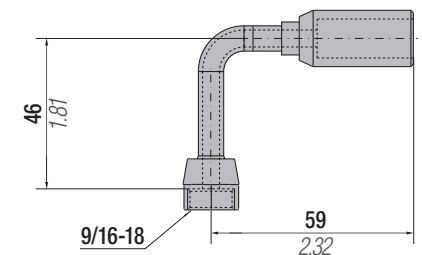

code 36P9/1607

■ 90° Swivel

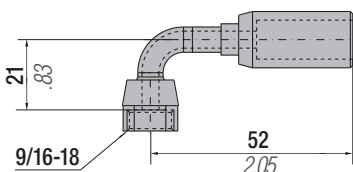

code 36P9/1608

■ 45° Swivel

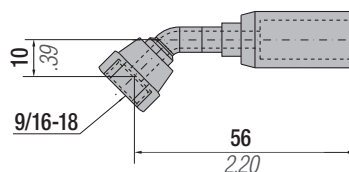

All dimensions in mm/inch

code 36TSM9/1601...

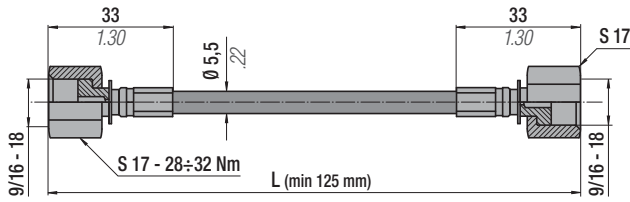

code 36TSM9/1602...

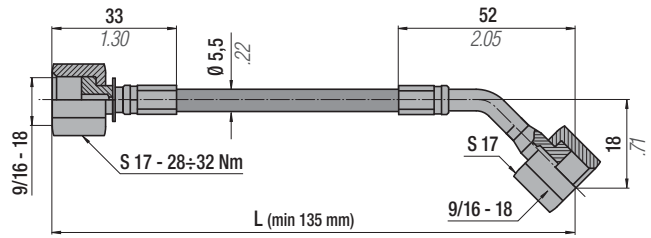

code 36TSM9/1603...

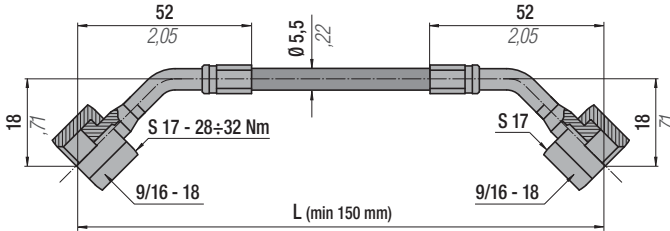

code 36TSM9/1604...

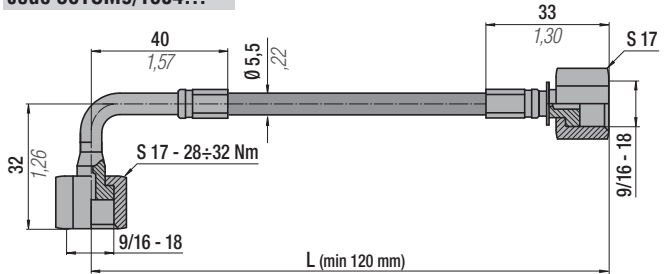

code 36TSM9/1605...

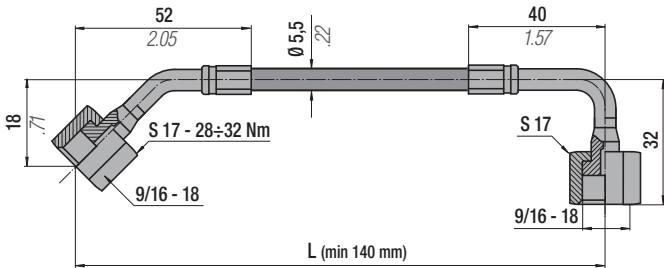

code 36TSM9/1606...

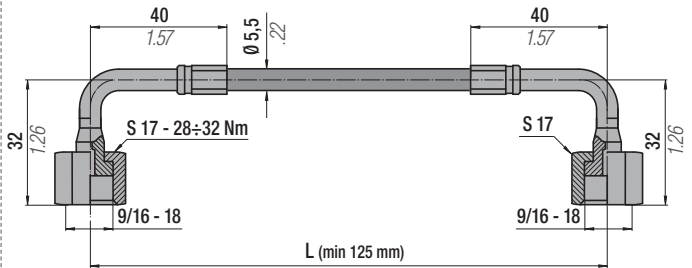

Technical data

"L" min	See above	-	Volume	3 ml/metre
Operation pressure	630 bar	9135 psi	Dimension	5/64" (external Ø 5,5 mm)
Burst Pressure	1890 bar at 20°C	27400 psi at 68°F	Material	Thermoplastic
R (bending radius)	20 mm	0,79 in	Standard	-
Operation temperature	-40+ 100°C	-38 +212°F	Outer casing	Perforated



Lunghezza richiesta comprensiva di raccordi terminali
Length upon request including end hose fittings
Länge Anfrage einschließlich Ende Schlaucharmaturen

Longueur requise, y compris des raccords d'extrémité
Longitud requerida, incluyendo accesorios de los extremos
Comprimento necessário incluindo todos os acessórios

standard L = 90 mm min. - 10 mm upward increase - Example (36TSM9/1601 0300; 36TSM9/1605 0310; ...)

code: 36FF06A

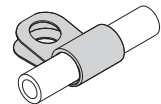
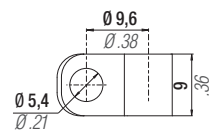
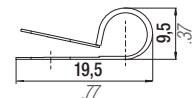

HOSE FITTINGS

code 36P9/1601

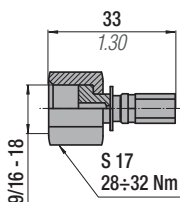

code 36P9/1602

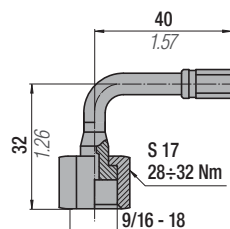

code 36P9/1603

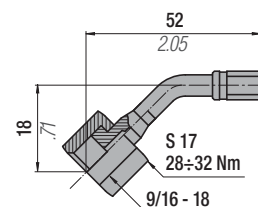

All dimensions in mm/inch

Raccordi tubo-cilindro/pannello - Hose-cylinder/panel connections - Anschlüsse zwischen schlauch und Zylinder/Kontrollarmatur - Raccords tuyau-cylindre/tableau - Conexiones sistema de cilindros/panel - Racord tubo-cilindro/panel

code PA-S Port Adapter - Straight

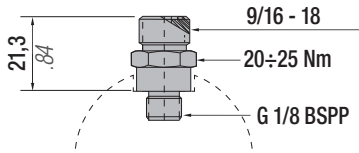

code PA-AS Port Adapter - Angle Swivel

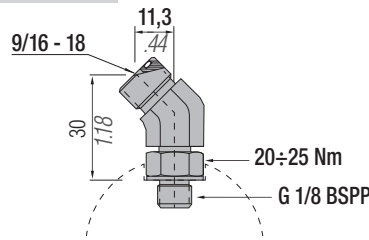

code PA-E Port Adapter - Elbow

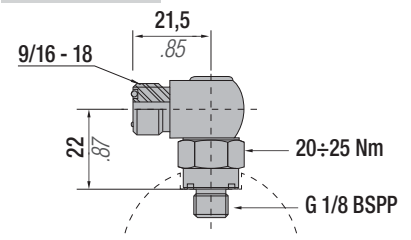

code PA-BTS Port Adapter - Branch Tee Swivel

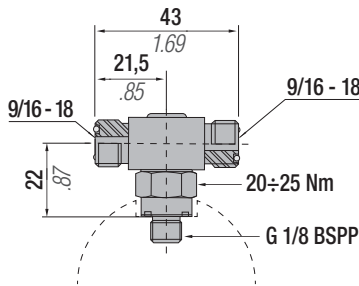

code PA-RT Port Adapter - Run Tee

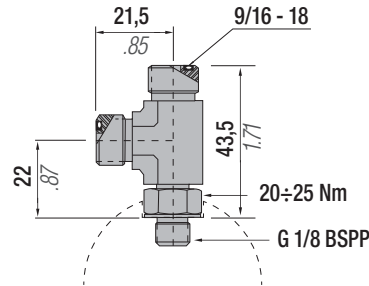

code PA-TWS Port Adapter - Two Way Swivel

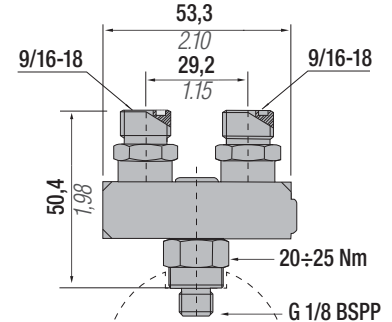

code PA-MWS Port Adapter - Multi Way Swivel

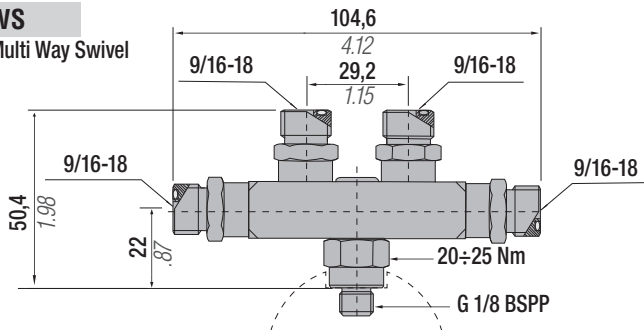

code PA-M6

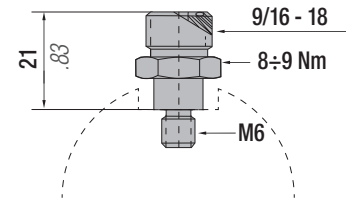

Raccordi di derivazione - Offtake connections - Anschlußstutzen - Raccords de dérivation - Racores - Racord de derivação

code SN-A Swivel Nut-Angle

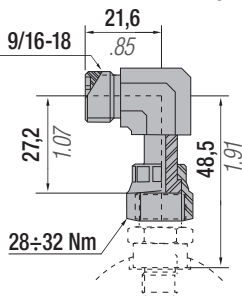

code SN-BT Swivel Nut-Branch Tee

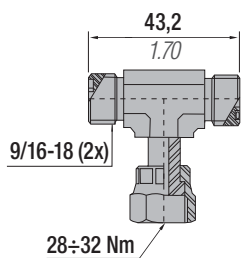

code SN-RT Swivel Nut-Run Tee

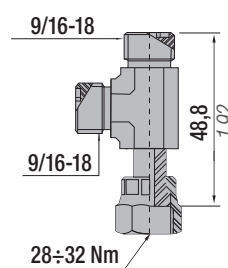

Raccordi tubo-tubo - Hose-hose connections - Anschlüsse zwischen Schlauch und Schlauch - Raccords tuyau-tuyau - Conexiones de tubo a tubo - Racord tubo-tubo

code F-U Fitting-Union

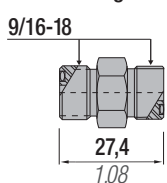

code F-E Fitting-Elbow

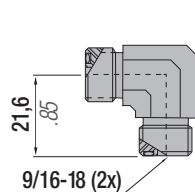

code F-T Fitting-Tee

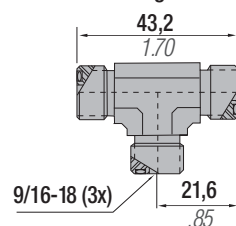

code F-C Fitting-Cross

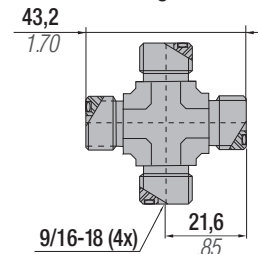

All dimensions in **mm/inch**



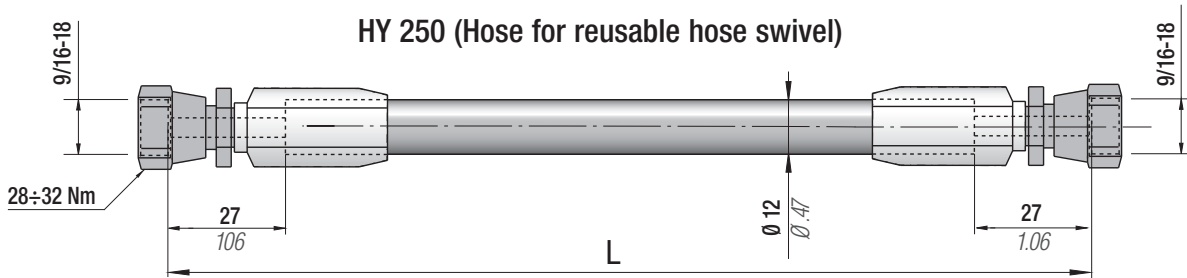

Technical data				
"L" min	254 mm	10,0 in	Volume	31 ml/metre
Operation pressure	190 bar	2750 psi	Dimension	1/4" (external Ø 12 mm)
Burst Pressure	758 bar at 20°C	11000 psi at 68°F	Material	Thermoplastic
R (bending radius)	38 mm	1,5 in	Standard	SAE 100R7
Operation temperature	-40+ 100°C	-38 +212°F	Outer casing	Perforated

standard L = 254 mm min. - Example(3) (36HY40005 12"(305); Length upon request including end hose fittings

REUSABLE HOSE SWIVELS

code SHF-R

Straight Swivel

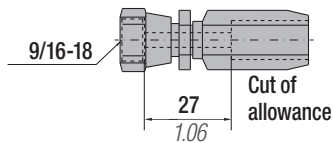

code HF-R90

90° Swivel

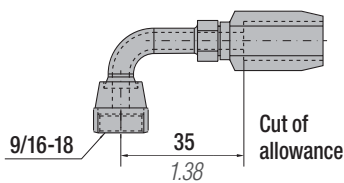

code HF-R45

45° Swivel

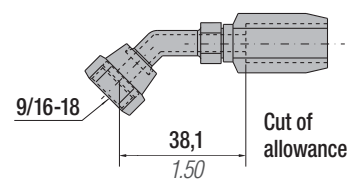



THIS PAGE IS INTENTIONALLY LEFT BLANK

code 36HY40001...

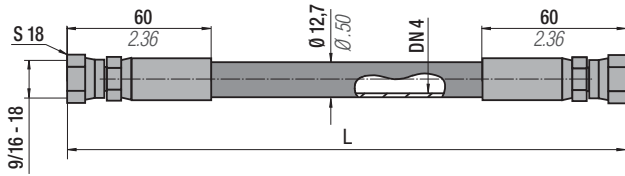

code 36HY40002...

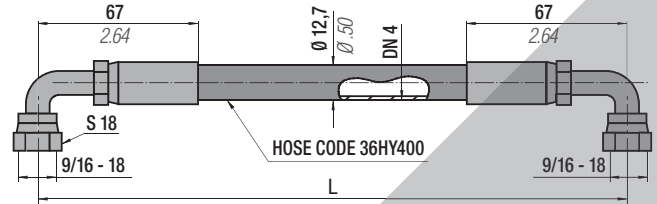

code 36HY40003...

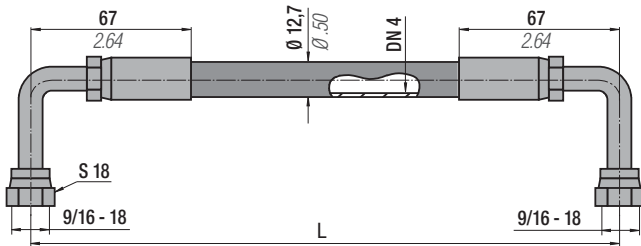

code 36HY40004...

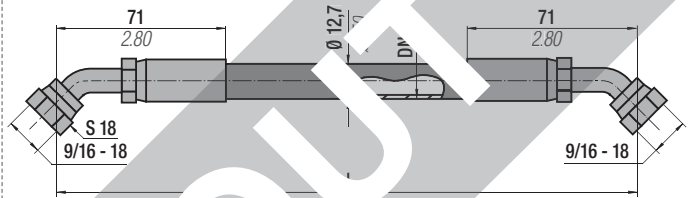

code 36HY40005...

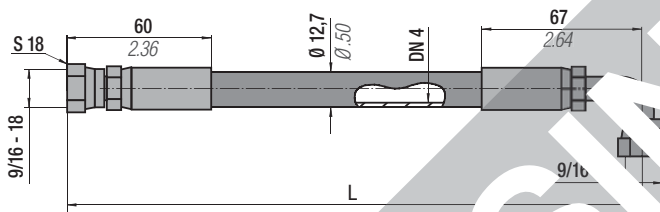

code 36HY40006...

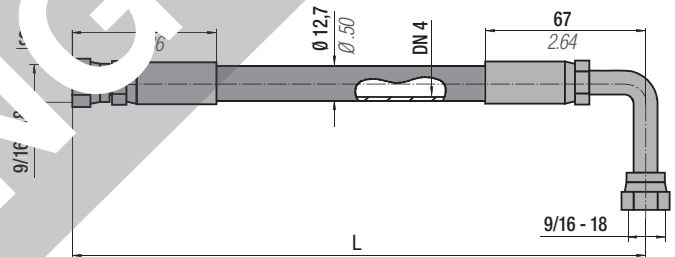

code 36HY40007...

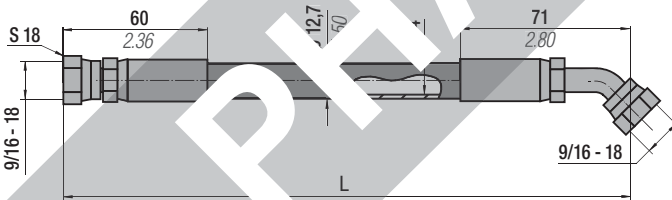

code 36HY40008...

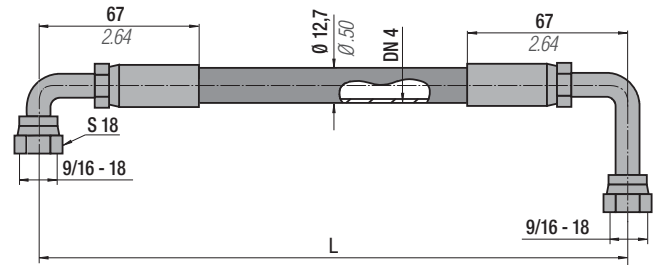

code 36HY40009...

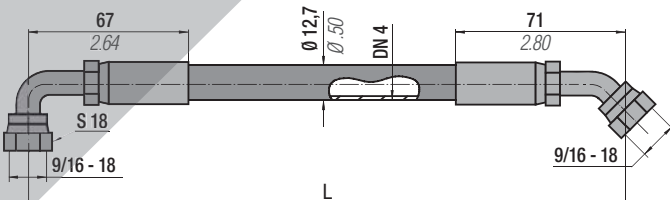

code 36HY40010...

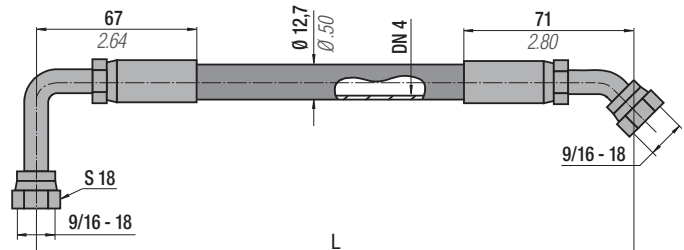

All dimensions in **mm/inch**

code 36HY40011...

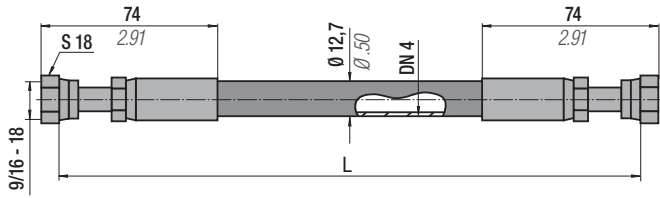

code 36HY40012...

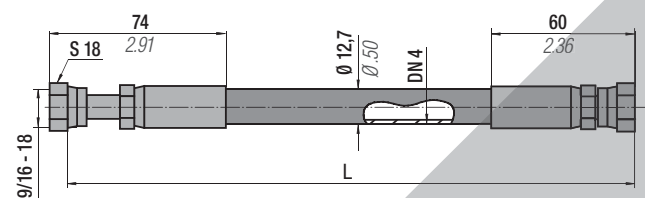

code 36HY40013...

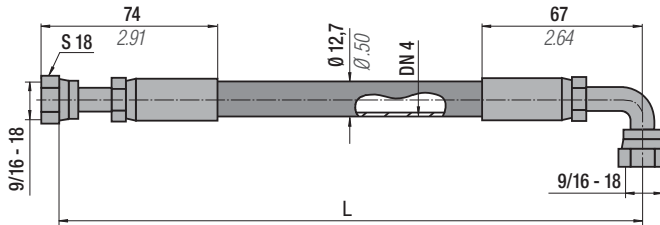

code 36HY40014...

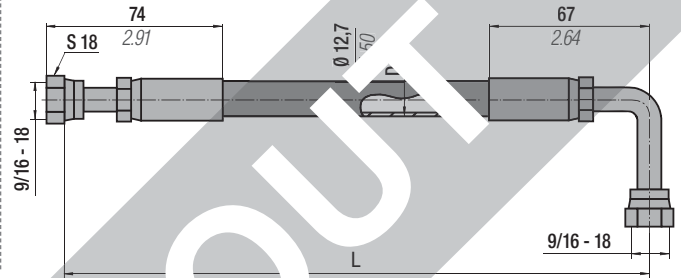

code 36HY40015...

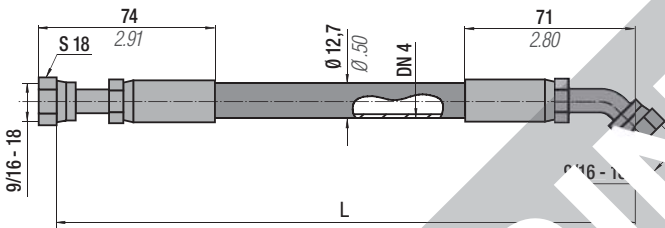

code: 36FF13A

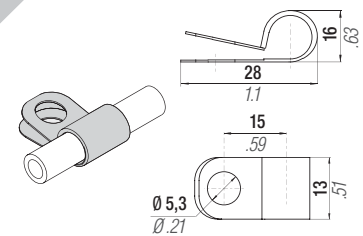

Technical data

"L" min	255 mm	20016	Volume	32 ml/metre
Operation pressure	345 bar	20016	Dimension	1/4" (external Ø 12,7 mm)
Burst Pressure	1380 bar at 20°C	20016	Material	Thermoplastic
R (bending radius)	51 mm	20016	Standard	SAE 100R8
Operation temperature	-40+120°C	20016	Outer casing	Perforated



Lunghezza richiesta comprensiva di raccordi terminali
 Length upon request including end hose fittings
 Länge Anfrage einschließlich Ende Schlaucharmaturen
 Longueur requise, y compris des raccords d'extrémité
 Longitud requerida, incluyendo accesorios de los extremos
 Comprimento necessário incluindo todos os acessórios

standard L = 255 mm / 10.04 in. / 5 mm / 0.197 in. per word increase - Example (36HY40016 0300; 36HY40016 0305; ...)

HOSE FITTINGS

code S-F

Straight Swivel

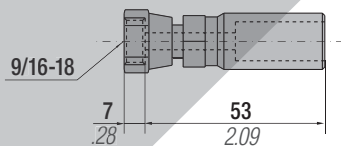

code S-FL

Straight Long Swivel

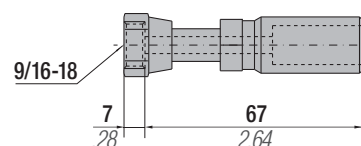

code H-F90L

90° Long Swivel

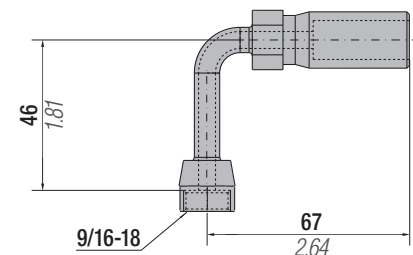

code H-F

90° Swivel

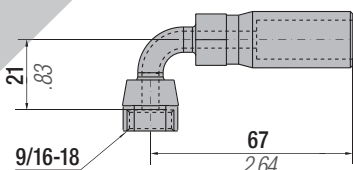

code H-F45

45° Swivel

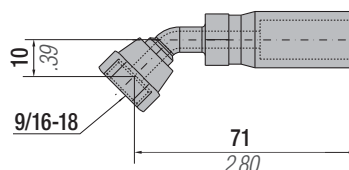

All dimensions in mm/inch

CONTROL PANEL CP01A



IT

Micro pannello di controllo composto da base in alluminio, manometro, valvola per caricamento e scaricamento, tappo di rottura sovrappressione e protezione in acciaio. Idoneo per la gestione di impianti collegati realizzati con micro hose e micro connections. 16 uscite M6.

EN

Micro control panel with aluminium base, gauge, charging and discharging valve, overpressure rupture plug and steel protection. Suitable for hose systems equipped with micro hose and micro connections. 16 M6 ports.

DE

Micro-Kontrollarmatur mit Aluminiumsockel, Manometer, Auffüll- und Ablassventil, Überdruck Bruch Stecker und Stahlabdeckung. Geeignet für Verbundsysteme mit Micro-Kupplung und -Schläuchen. 16 M6 Anschlüsse.

FR

Mini panneau de contrôle avec base aluminium, équipé de manomètre, valve de chargement et déchargement, bouchon de rupture de surpression et protection acier ; il est adapté aux systèmes connectés équipés de mini tuyaux et mini connexions. 16 Portes M6.

ES

Micropanel de control con base en aluminio, manómetro, válvula de carga y descarga, enchufe de la ruptura de sobrepresión y protección en acero. Idóneo para la gestión de instalaciones de cilindros conectados entre sí con micro mangueras y micro conectores. 16 salidas M6.

PT

Micro Painel de Control com base em alumínio, manómetro, válvula de carga e descarga, plugue ruptura sobrepresão e protecção em aço. Adequado para sistemas de mangueiras, equipado com micro mangueiras e micro conexões. 16 saídas M6.

code	Pressure Gauge	Rupture Plug
39CP01A	bar/psi	✓

easu
MANIFOLD

👉 p. 211

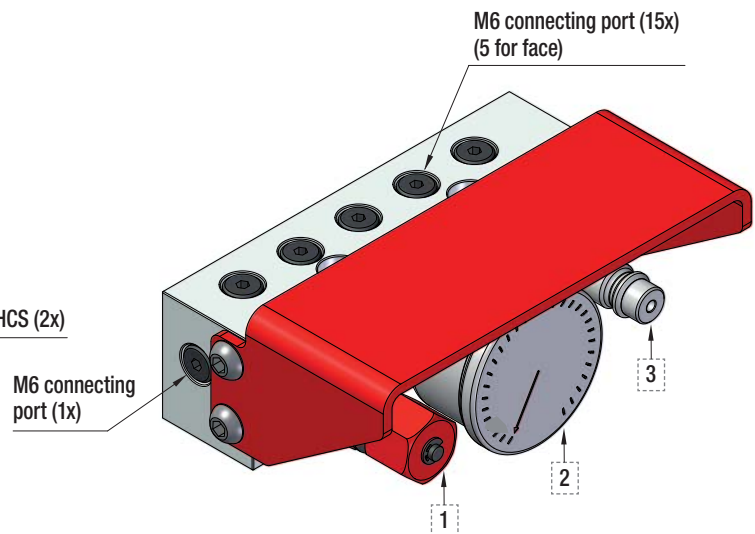
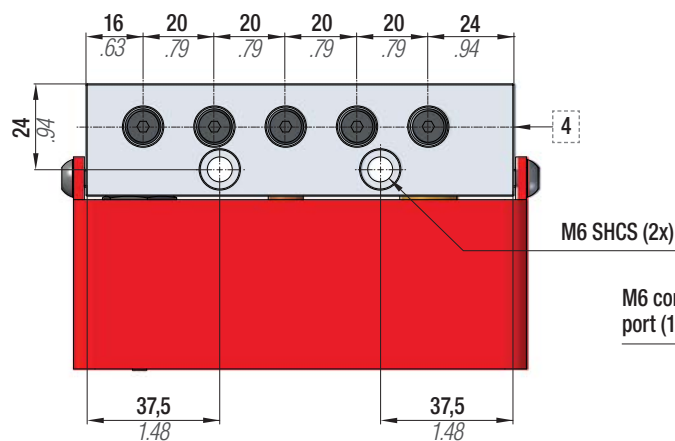
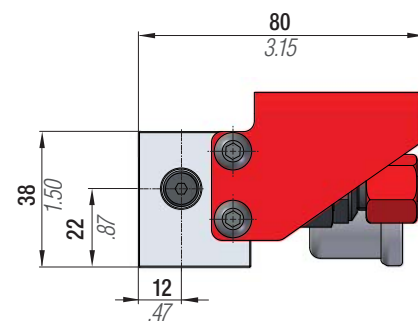
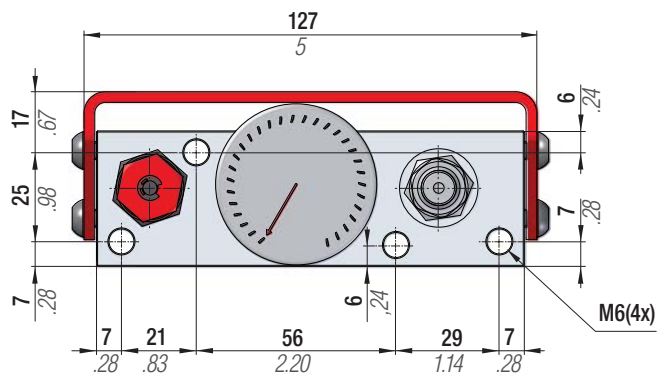

1	Valvola di scarico Discharging valve Auslaßventil Valve de déchargement Válvula de desahogo Válvula de descarga	2	Manometro 0÷ 620 bar Pressure gauge 0÷620 bar Manometer 0÷ 620 bar Manomètre 0÷ 620 bar Manómetro 0÷ 620 bar Manómetro 0÷ 620 bar	3	Innesto rapido di caricamento Cejn Quick coupling for charging Cejn Steckkegel Cejn Accouplement rapide mâle Cejn Acoplamiento rápido para carga Cejn União rápida para carregamento Cejn	4	Tappo di rottura sovrappressione Over pressure rupture plug Überdruck Bruch Stecker Bouchon de rupture de surpression Enchufe de la ruptura de sobrepresión Plugue ruptura sobrepresão
---	--	---	--	---	--	---	---

IT

Pannello standard per caricamento, regolazione, scaricamento e controllo della pressione nel sistema collegato. Consiste in una base provvista di manometro, valvola di caricamento e scaricamento, 3 uscite, protezione in acciaio. Può essere equipaggiato con disco di rottura (opzionale).

EN

Standard control panel to charge, adjust and check the pressure in the connected system. It consists of a plate with pressure gauge, charging and discharging valve, 3 outlets, steel case and can be equipped with a rupture disc (optional).

DE

Standard-Schalttafel zur Ladung, Regulierung, Entladung und Kontrolle des Drucks im angeschlossenen System. Bestehend aus einer Basis mit Manometer, Lade- und Entladeventil, 3 Ausgängen sowie Schutz aus Stahl. Kann mit einer Berstscheibe ergänzt werden (Zubehör).

FR

Panneau standard pour le chargement, le réglage, le déchargement et le contrôle de la pression dans le système relié. Il est formé par une embase équipée de manomètre, vanne de chargement et déchargement, 3 sorties, protection en acier. Il peut être équipé d'un disque de rupture (option).

ES

Panel standard para la carga, regulación, descarga y control de la presión en sistemas de cilindros conectados. Consiste en una base con un manómetro Válvula de carga y descarga, 3 salidas, protección en acero. Puede equiparse con disco de ruptura (opcional).

PT

Painel standard para carga, regulação, descarga e controlo da pressão no sistema ligado. É composto por uma base com manómetro. Válvula de carga e de descarga, 3 saídas, protecção em aço. Pode ser equipado com disco de rotura (opcional).

code	Pressure Gauge	Rupture Plug
39CPVC	bar/psi	✗
39CPVC + 39DR004	bar/psi	✓
39CPVC + 39TS460	bar/psi	✓

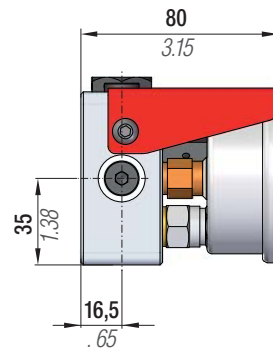
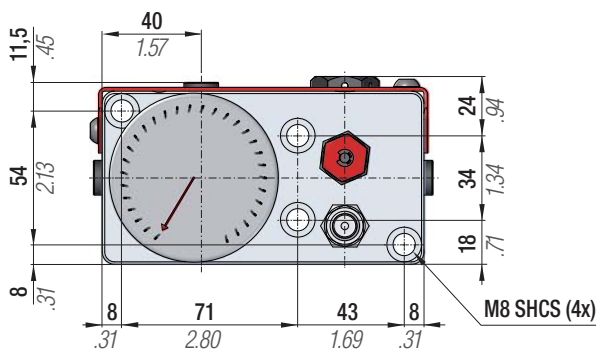

code 39TS460	4.2 - option
code 39DR004	4.1 - option
	standard 4

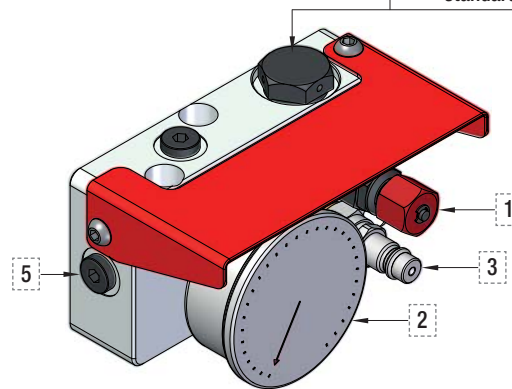
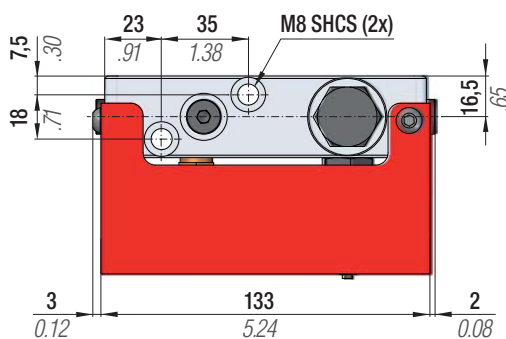

1	Valvola di scarico Discharging valve Auslaßventil Valve de déchargement Válvula de desahogo Válvula de descarga	2	Manometro 0÷ 620 bar Pressure gauge 0÷620 bar Manometer 0÷ 620 bar Manomètre 0÷ 620 bar Manómetro 0÷ 620 bar Manómetro 0÷ 620 bar	3	Innesto rapido di caricamento Cejn Quick coupling for charging Cejn Steckkegel Cejn Accouplement rapide mâle Cejn Acoplamiento rápido para carga Cejn União rápida para carregamento Cejn	4	Tappo di chiusura M20 Closing plug M20 Verschlussstopfen M20 Bouchon de fermeture M20 Tapon de cierre M20 Plugue de fechamento M20	code: 39TS460
4.1	Tappo di rottura sovrappressione Over pressure rupture plug Überdruck Bruch Stecker Bouchon de rupture de surpression Enchufe de ruptura de sobrepresión Plugue ruptura sobrepresão	4.2	Tappo di sicurezza sovrappressione CE Overpressure safety plug CE Überdruck Sicherheitsstecker CE Bouchon de sécurité surpression CE Enchufe de seguridad sobrepresion CE Bujão de segurança sobrepresão CE	5	Fori di collegamento 1/8"G (4x) 1/8"G connecting ports (4x) Anschlussöffnung 1/8"G (4x) Trous de raccordement 1/8"G (4x) Agujeros de conexión 1/8"G (4x) Furo de conexão 1/8"G (4x)			

CONTROL PANEL MCPC



Replace code 39MCPB



IT

Il mini pannello di controllo Special Springs, grazie a un design miniaturizzato e unico, offre una grande flessibilità d'uso che aumenta con le unità aggiuntive AUMCP. Consiste in un blocchetto di alluminio provvisto di manometro, valvola di caricamento e scaricamento, 4 uscite, valvola d'intercettazione e tappo di rottura sovrappressione.

EN

The Special Springs mini control panel, thanks to its unique miniaturized design, offers wide flexibility of use, increased when combined with additional AUMCP units. It consists of a aluminium block with pressure gauge, charging and discharging valve, 4 outlets, on-off valve and overpressure rupture plug.

DE

Die Mini-Steuerung Special Springs bietet dank ihres miniaturisierten und einzigartigen Designs größte Benutzungsflexibilität, die mit den zusätzlichen AUMCP-Einheiten noch erhöht wird. Bestehend aus einem Aluminiumblock mit Manometer, Lade- und Entladeventil, 4 Ausgängen, Sperrventil und Überdruck Bruch Stecker.

FR

Grâce à une conception miniaturisée et unique, le mini-panneau de contrôle Special Springs offre une grande souplesse d'utilisation qui augmente avec les unités supplémentaires AUMCP. Il est formé par une plaque en aluminium équipée de manomètre, vanne de chargement et déchargement, 4 sorties, vanne d'arrêt et Bouchon de rupture surpression.

ES

El mini-panel de control Special Springs, gracias a su exclusivo diseño miniaturizado, ofrece una gran flexibilidad, que aumenta con las unidades adicionales AUMCP. Consiste en una placa de aluminio con manómetro, válvula de carga y descarga, 4 salidas, válvula de interceptación y enchufe de ruptura de sobrepresión.

PT

O mini-pannel de controlo Special Springs, graças a um design miniaturizado e exclusivo, oferece uma grande flexibilidade de utilização que aumenta com as unidades adicionais AUMCP. É composto por um bloco em alumínio com manómetro, válvula de carga e de descarga, 4 saídas, válvula de interceptação e plugue de ruptura sobrepresão.

code	Pressure Gauge	Rupture Plug
39MCPC	bar/psi	✓

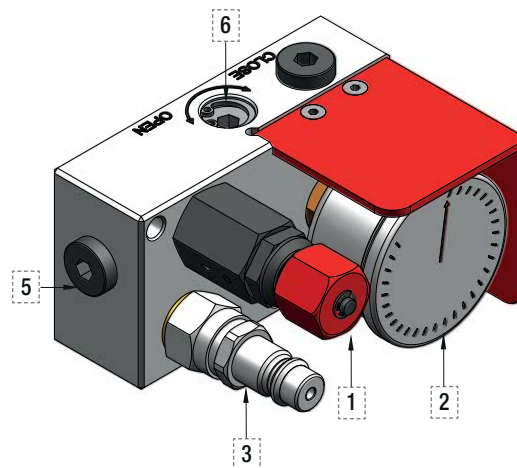
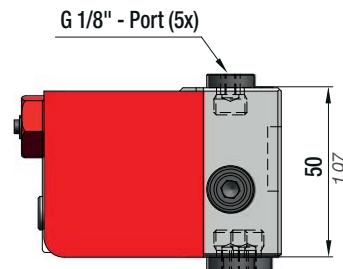
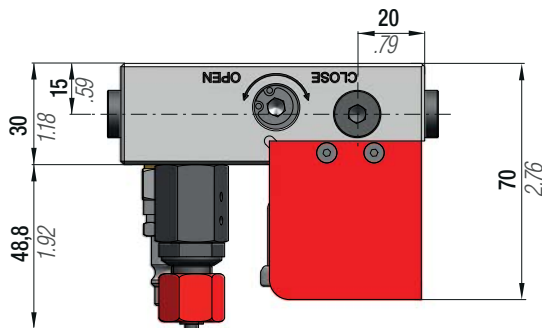
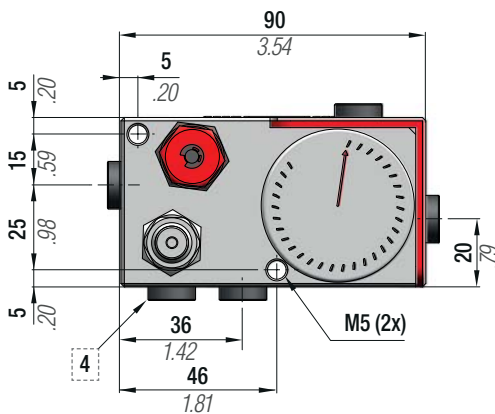

1	Valvola di scarico Discharging valve Auslaßventil Valve de déchargement Válvula de desahogo Válvula de descarga	2	Manometro 0÷ 620 bar Pressure gauge 0÷620 bar Manometer 0÷ 620 bar Manomètre 0÷ 620 bar Manómetro 0÷ 620 bar Manómetro 0÷ 620 bar
3	Innesto rapido di caricamento Quick coupling for charging Steckkegel Cejn Accouplement rapide mâle Cejn Acoplamiento rápido para carga União rápida para carregamento Cejn	4	Tappo di rottura sovrappressione Over pressure rupture plug Überdruck Bruch Stecker Bouchon de rupture de surpression Enchufe de la ruptura de sobrepresión Plugue ruptura sobrepresão
5	Fori di collegamento 1/8" G (5x) 1/8" G connecting ports (5x) Anschlussöffnung 1/8" G (5x) Trous de raccordement 1/8" G (5x) Agujeros de conexión 1/8" G (5x) Furo de conexão 1/8 G (5x)	6	Valvola di intercettazione Shut off valve Sperrventil Valve d'arrêt Válvula de interceptación Válvula de fecho



p. 211

IT

Unità aggiuntive per minipannello MCPC. Ideali per gestire impianti o cilindri singoli con pressioni diverse nello stesso stampo. Ogni unità include un manometro, una valvola di intercettazione e 1 uscita. Combinazione massima prevista 1 MCPC + 4 AUMCP.

EN

Additional units for the mini control panel MCPC. Ideal for operating hoses systems or single cylinders with different pressures in the same mould. Each unit includes pressure gauge, on-off valve and 1 outlet. Designed for a maximum combination of 1 MCPC + 4 AUMCP.

DE

Zusätzliche Einheiten für die Ministeuerung MCPC. Ideal zur Verwaltung von Anlagen oder einzelnen Zylindern, die beim selben Formprozess verschiedene Druckwerte aufweisen. Jede Einheit ist mit einem Manometer, einem Sperrventil und einem Ausgang ausgestattet. Maximal mögliche Kombination: 1 MCPC + 4 AUMCP.

FR

Unités supplémentaires pour le mini-panneau MCPC. L'idéal pour gérer des installations ou des cylindres seuls sous des pressions différentes dans le même moule. Chaque unité inclut un manomètre, une vanne d'arrêt et 1 sortie. Combinaison maximum prévue: 1 MCPC + 4 AUMCP.

ES

Unidades adicionales para mini-panel MCPC. Ideales para la gestión de sistemas o de cilindros aislados con presiones distintas en un mismo molde. Cada unidad incluye un manómetro, una válvula de interceptación y 1 salida. Combinación máxima prevista 1 MCPC + 4 AUMCP.

PT

Unidade adicional para mini-painel MCPC. Ideais para gerir instalações ou cilindros individuais com pressões diferentes na mesma ferramenta. Cada unidade inclui um manómetro, uma válvula de interceptação e 1 saída. Combinação máxima prevista 1 MCPC + 4 AUMCP.

code	Pressure Gauge	Rupture Plug
39AUMCP	bar/psi	✓

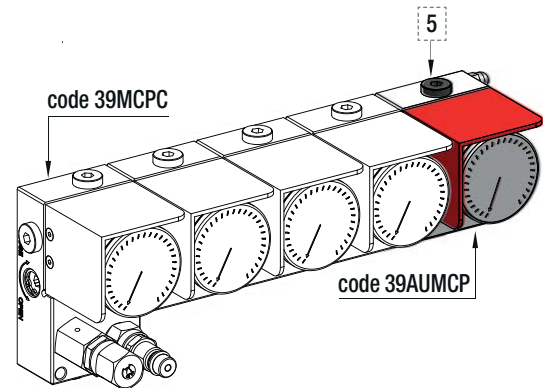
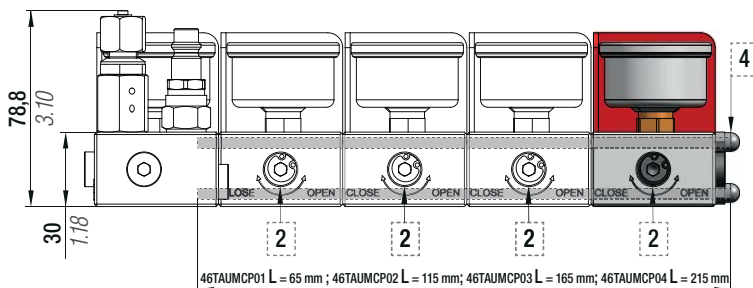
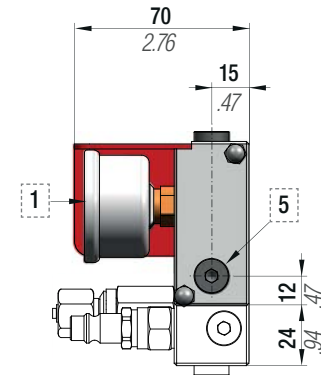
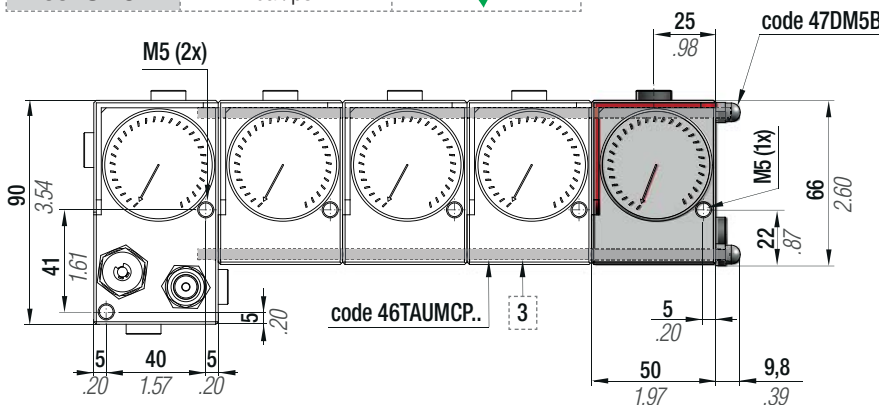

1	Manometro 0÷ 620 bar Pressure gauge 0÷ 620 bar Manometer 0÷ 620 bar Manomètre 0÷ 620 bar Manómetro 0÷ 620 bar	Valvola di intercettazione Shut off valve Sperrventil Valve d'arrêt Válvula de interceptación Válvula de fecho	Tirante (2x) Tie rod (2x) Zugstange (2x) Tirant (2x) Tirante (2x) Barra de ligação (2x)	Dado cieco (2x) Cap nut (2x) Hutmutter (2x) Écrou borgne (2x) Tuerca de sombrerete (2x) Porca cega (2x)	Fori di collegamento 1/8"G (2x) 1/8"G connecting ports (2x) Anschlussöffnung 1/8"G (2x) Trous de raccordement 1/8"G (2x) Agujeros de conexión 1/8"G (2x) Furo de conexão 1/8G (2x)
---	---	---	--	--	---

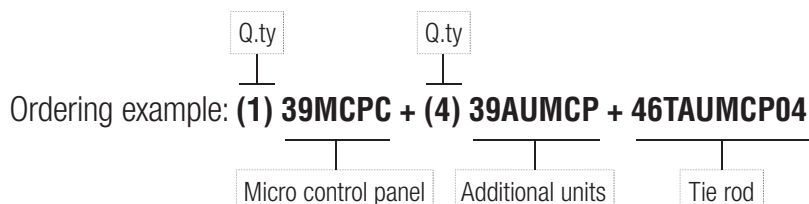

Ordering options code

- (1) 39MCPC + (1) 39AUMCP + 46TAUMCP01
- (1) 39MCPC + (2) 39AUMCP + 46TAUMCP02
- (1) 39MCPC + (3) 39AUMCP + 46TAUMCP03
- (1) 39MCPC + (4) 39AUMCP + 46TAUMCP04

CONTROL PANEL CP02A / CP08A / CP11A ■ (FORD and GM North America die Standard)



IT

Pannello di controllo secondo standard Ford e GM Nord America. Base in alluminio provvista di manometro, valvola di caricamento e scaricamento, adattatore 9/16-18 UNF ORFS, tappo di rottura sovrappressione e protezione in acciaio. 3 uscite G1/8" per gestione sistemi collegati.

EN

Control panel according to Ford and GM North America standards. Made up of aluminium base. Gauge, charging and discharging valve, 9/16-18 UNF ORFS adapter, over pressure rupture plug and steel protection. 3 ports G1/8".

DE

Kontrollarmatur gem. Ford und GM North America Normen. Aufgebaut auf Aluminiumsockel. Manometer, Auffüll- und Ablassventil, 9/16-18 UNF ORFS Adapter, Überdruck Bruch Stecker und Stahlabdeckung. 3 G1/8" Anschlüsse.

FR

Panneau de contrôle selon les standards Ford et GM, Amérique du Nord, base en aluminium. Manomètre, valve de chargement et déchargement, adaptateur 9/16-18 UNF ORFS, Bouchon de rupture de surpression et protection acier, 3 ports G1/8".

ES

Panel de control según standard Ford y GM Norte America. Base de aluminio con manómetro, válvula de carga y descarga, adaptador 9/16-18 UNF ORFS, Enchufe de ruptura de sobre presión y protección en acero. 3 salidas G1/8" para sistemas de cilindros conectados.

PT

Painel de controlo de acordo com os Standards Ford e GM América do Norte. Fabricado a partir de uma base de alumínio, manómetro, válvula de carga e descarga, adaptador ORFS 9/16-18 UNF, Plugue ruptura sobre pressão e protecção em aço. 3 saídas G1/8" para sistemas de gestão relacionados.

code	Pressure Gauge	Rupture Plug
39CP02A	bar/psi	✓
39CP08A	bar/MPa	✓
39CP11A ■	bar/psi	✗

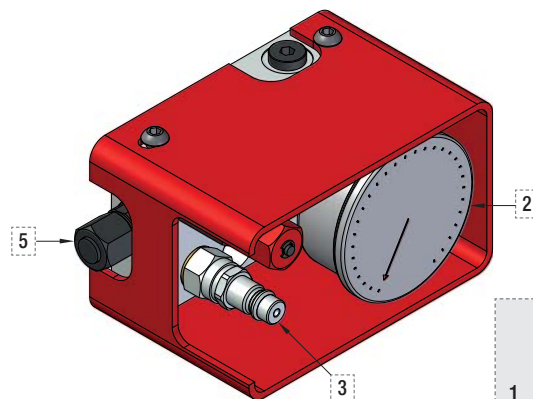
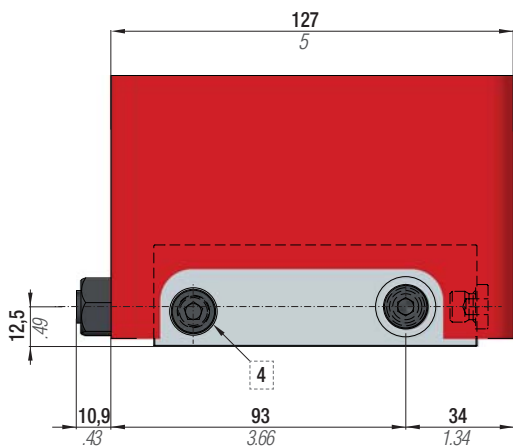
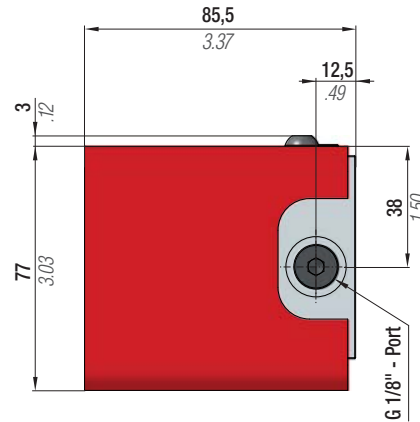
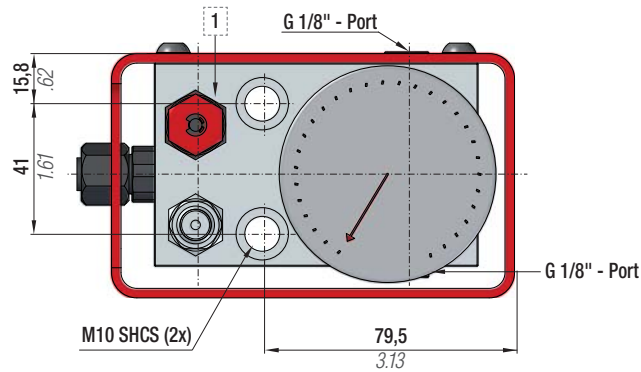

1 Valvola di scarico
Discharging valve
Auslaßventil
Valve de déchargement
Válvula de desahogo
Válvula de descarga

2 Manometro 0÷ 620 bar Pressure gauge 0÷ 620 bar Manometer 0÷ 620 bar Manomètre 0÷ 620 bar Manómetro 0÷ 620 bar Manómetro 0÷ 620 bar	3 Innesso rapido di caricamento Cejn Quick coupling for charging Cejn Steckkegel Cejn Accouplement rapide mâle Cejn Acoplamiento rápido para carga Cejn União rápida para carregamento Cejn	4 Tappo di rottura sovrappressione Over pressure rupture plug Überdruck Bruch Stecker Bouchon de rupture de surpression Enchufe de la ruptura de sobre presión Plugue ruptura sobre pressão	5 Adattatore tenuta frontale 9/16-18 UNF O-Ring Face Seal Adapter 9/16-18 UNF O-ring-Dichtung Adapter 9/16-18 UNF Joint torique adaptateur 9/16-18 UNF O-ring face seal adapter 9/16-18 UNF Adaptador de vedação frontal 9/16-18 UNF
---	--	--	---

IT

Pannello di controllo con base in alluminio, provvi manometro con valvola di intercettazione, valvola di caricamento e scaricamento, tappo di rottura sovrappressione, protezione in acciaio, 9 uscite da G1/4" per gestione sistemi collegati. La valvola di intercettazione protegge il manometro dalla pressione pulsante durante il funzionamento. Per controllare e regolare la pressione dell'impianto bisogna aprire la valvola di intercettazione del manometro.

EN

Control panel with aluminium base, gauge with shut-off valve, charging and discharging valve, over pressure rupture plug, steel protection. 9 G1/4" ports for hose systems managing. With shut-off valve closed the gauge is protected from pulsating pressure during operation. For checking and adjusting the pressure the interception valve on the gauge must be opened.

DE

Kontrollarmatur mit Aluminiumsockel, Manometer mit Sperrventil, Auffüll- und Ablassventil, Überdruck Bruch Stecker und Stahlabdeckung. 9 G1/4" Anschlüsse zur Steuerung der Verbundsysteme. Das Schließen des Manometers mit dem Sperrventil schützt vor Druckschwankungen während des Arbeitsgangs. Zum Prüfen und Einstellen des Drucks muss das Sperrventil am Manometer geöffnet sein.

FR

Panneau de contrôle avec embase aluminium, équipé de manomètre à valve d'arrêt, valve de chargement et déchargement, bouchon de rupture de surpression et protection acier. Ports 9 G1/4" pour gestion de la connectique. Lorsque la valve d'arrêt est fermée, le manomètre est protégé des vibrations dues à la pression durant les opérations. Pour contrôler et ajuster la pression, il convient d'ouvrir la valve d'interception au niveau du manomètre.

ES

Panel de control con base de aluminio, manómetro con válvula de interceptación (shut-off valve), válvula de carga y descarga, enchufe de ruptura de sobrepresión protección en acero. 9 salidas G1/4" para gestión de sistemas interconectados. Con válvula de interceptación cerrada el manómetro está protegido desde el pico de presión durante un funcionamiento normal. Para controlar y regular la presión abrir la válvula de interceptación del manómetro.

PT

Painel de Controlo com base em alumínio, manómetro com válvula de obturação, plugue ruptura sobrepresão e protecção em aço. 9 furos* G1/4" para uso de sistemas de mangueiras. Com a válvula de obturação fechada fica protegido das pressões existentes durante a operação. Para verificar e ajustar a pressão, a válvula de intercepção no manómetro tem que estar aberta.

code	Pressure Gauge	Rupture Plug
39CP03A	bar/psi	✓

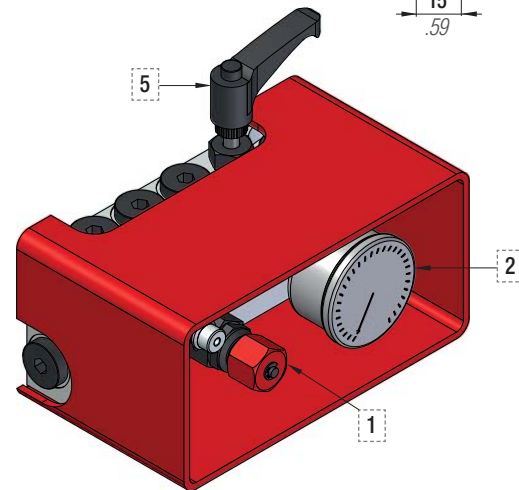
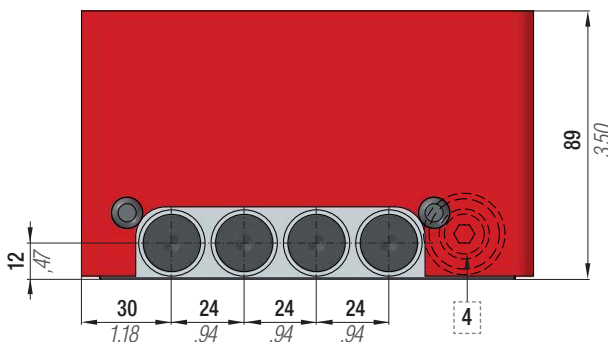
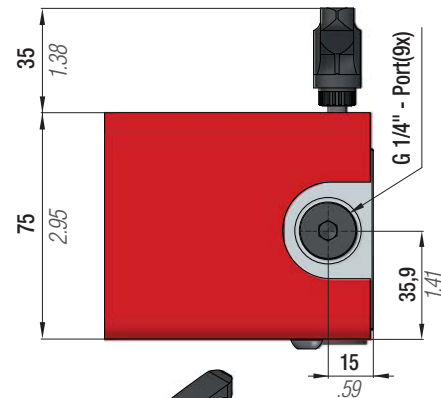
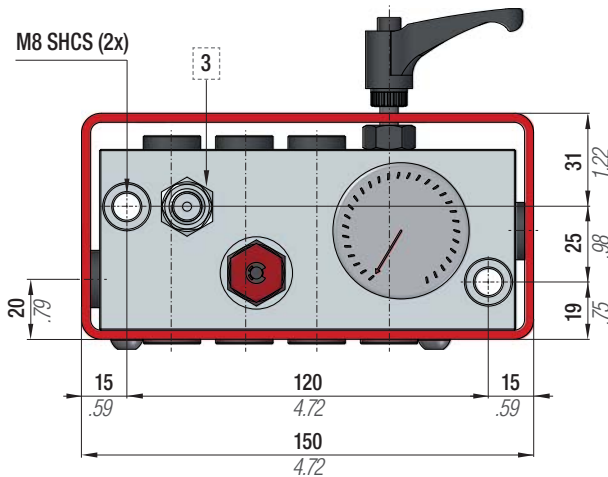

1	Valvola di scarico Discharging valve Auslaßventil Valve de déchargement Válvula de desahogo Válvula de descarga	2	Manometro 0÷ 620 bar Pressure gauge 0÷ 620 bar Manometer 0÷ 620 bar Manomètre 0÷ 620 bar Manómetro 0÷ 620 bar Manómetro 0÷ 620 bar	3	Innesto rapido di caricamento Cejn Quick coupling for charging Cejn Steckkegel Cejn Accouplement rapide mâle Cejn Acoplamiento rápido para carga Cejn União rápida para carregamento Cejn	4	Tappo di rottura sovrappressione Over pressure rupture plug Überdruck Bruch Stecker Bouchon de rupture de surpression Enchufe de la ruptura de sobrepresión Plugue ruptura sobrepresão	5	Valvola di intercettazione Shut off valve Sperrventil Valve d'arrêt Válvula de interceptación Válvula de fecho
---	--	---	---	---	--	---	---	---	---



CONTROL PANEL CP06A / CP09A



IT
Pannello di controllo con base in alluminio provvisto di sensore di pressione con display digitale, valvola di caricamento e scaricamento, tappo di rottura sovrappressione, protezione in acciaio, 2 uscite da 1/8" gas per gestione sistemi collegati. Collegando direttamente il sensore di pressione al controllo pressa è possibile impostare un range di lavoro desiderato al di fuori del quale il dispositivo invierà un segnale di allarme.

EN
Control panel with aluminium base, equipped with pressure sensor with digital display, charging and discharging valve, over pressure rupture plug, steel protection and two 1/8" gas outlets for hose system managing. By connecting directly the pressure sensor with the Press control unit, it is possible to set a desired working range, outside this value, the control unit will send an alarm signal.

DE
Kontrollarmatur mit Aluminiumsockel, ausgestattet mit Drucksensor aus digitaler Display, auffüll- und Ablassventil, Überdruck Bruch Stecker, Stahlabdeckung und zwei 1/8" Anschlüsse zur Steuerung der Verbundsysteme. Bei der direkten Verbindung des Drucksensors mit Pressesteuerung es ist möglich eine erwünschte Arbeitsreichweite anzulegen, außerhalb diese Wert wird der Steuerung ein Alarm Signal zu senden.

FR
Panneau de contrôle avec embase en aluminium, équipé de senseur de pression à écran numérique, chargement et déchargement valve, Bouchon de rupture de surpression, protection en acier et deux sorties 1/8 gaz pour la gestion des systèmes connectés. En reliant directement le senseur de pression au système de gestion de la presse on peut établir un éventail désiré des valeurs de travail, au dehors de ces valeurs, le dispositif émettra un signal d'alarme.

ES
Panel de control con base de aluminio, provisto de sensor de presión con display digital, válvula de carga y descarga, Enchufe de ruptura de sobrepresión, protección en acero, 2 salidas de 1/8" gas para gestión de sistemas conectados. Conectando directamente el sensor de presión al control de la prensa es posible determinar unos rangos de trabajo, fuera de los cuales el dispositivo envía una señal de alarma.

PT
Painel de controlo com base de alumínio, equipado com sensor de pressão digital, válvula de carga e descarga, Plugue ruptura sobrepresão, sistema de protecção de aço e duas tomadas de 1/8" gas para ligação a mangueiras. ao ligar directamente o sensor de pressão com a unidade de controlo, é possível definir o funcionamento desejado, fora destes valores, a unidade de controlo envia um sinal de alarme.

code	Pressure Gauge	Rupture Plug
39CP06A with 59CD01A	bar/psi	✓
39CP09A with 59CR01A	bar/psi	✓

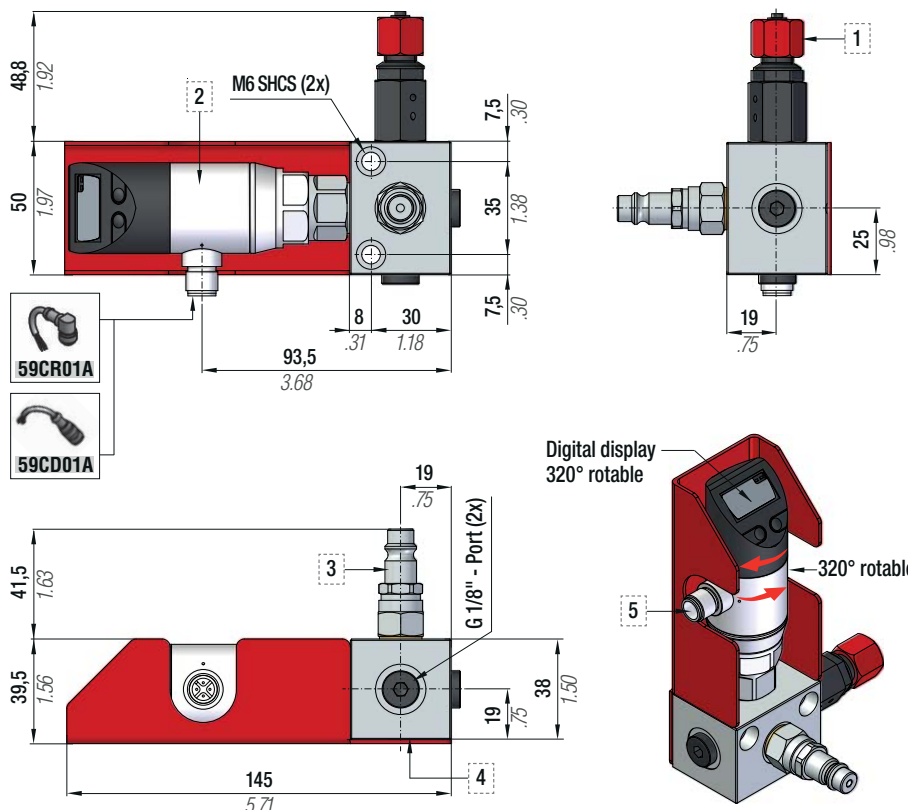

Technical data	
Electrical connector type	M12x1 (4-pin)
Pressure connection	G 1/4" DIN 3852
Nominal pressure	0 - 600 bar
Burst pressure	800 bar
Operating voltage U _o	18...36 V DC
Output current max.	500 mA
No-load supply current I _o max	≤ 50 mA
Switching frequency f	200 Hz
Temperature range	- 25°C... + 85°C
Degree of protection as per IEC 60529	IP67 when connected
Output: digital data (switching points only) 2 x PNP, NO/NC selection	

⚠ Always depressurize and disconnect pressure sensors from the power supply before establishing an electrical connection.

Electrical connections	Sensors with switching output	Sensors with analog output	Wire connections color
Supply +	1	1	Brown
Supply -	3	3	Blue
Signal +	-	2	White
Switching output 1	4	4	Black
Switching output 2	2	-	-
Shield	Connector housing	Connector housing	-

Fig. 1: Sensor diagram with 2 switching outputs

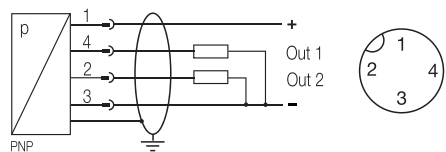
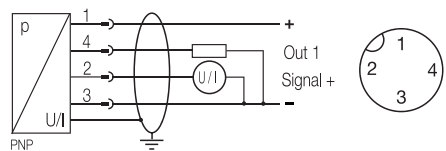

Fig. 2: Sensor diagram with analog output



1 Valvola di scarico Discharging valve Auslassventil Valve de déchargement Válvula de desahogo Válvula de descarga	2 Manometro 0÷ 600 bar Pressure gauge 0÷ 600bar Manometer 0÷ 600 bar Manomètre 0÷ 600 bar Manómetro 0÷ 600 bar Manómetro 0÷ 600 bar	3 Innesto rapido di caricamento Cejn Quick coupling for charging Cejn Steckkegel Cejn Accouplement rapide mâle Cejn Acoplamiento rápido para carga Cejn União rápida para carregamento Cejn	4 Tappo di rottura sovrappressione Over pressure rupture plug Überdruck Bruch Stecker Bouchon de rupture de surpression Enchufe de la ruptura de sobrepresión Plugue ruptura sobrepresão	5 Connettore elettrico Electrical connector Elektrische Connecteur électrique Eléctrica Conector Conector elétrico
--	---	---	--	--

■ CONTROL PANEL CP07A / CP10A / CP12A

IT

Pannello di controllo con base in alluminio provvisto di manometro, valvola di carica e scaricamento e scaricamento, tappo di rottura sovrappressione, protezione in acciaio, 3 uscite da 1/4" gas e un uscita da 1/8" gas per gestione sistemi collegati.

EN

Control panel with aluminium base, equipped with gauge, charging and discharging valve, over pressure rupture plug, steel protection and three 1/4" and one 1/8" gas outlets for hose system managing.

DE

Kontrollarmatur mit Aluminiumsockel, Manometer, auffüll- und Ablassventil, Überdruck Bruch Stecker, Stahlabdeckung, drei 1/4" und eine 1/8" Gas Anschlüsse zur Steuerung der Verbundsysteme.

FR



Panneau de contrôle avec base en aluminium, manomètre, valve de chargement-déchargement, bouchon de rupture de surpression, protection en acier et trois sorties 1/4 gaz et une sortie 1/8 gaz pour la gestion des systèmes connectés.

ES

Panel de control con base de aluminio provisto de manómetro, válvula de carga y descarga, enchufe de la ruptura de sobrepresión, protección en acero, 3 salidas de 1/4" gas y 1 salida de 1/8" gas para gestión de sistemas conectados.

PT

Painel de controlo com base de alumínio, equipado com manómetro, válvula de carga e descarga, plugue ruptura sobrepresão, sistema de protecção de aço, três tomadas de 1/4" e uma 1/8" gas para ligação a mangueras.

code	Pressure Gauge	Pressure Switch	Rupture Plug
39CP07A	bar/psi	✗	✓
39CP10A 	bar/psi	✓	✓
39CP12A 	bar/psi	✗	✗

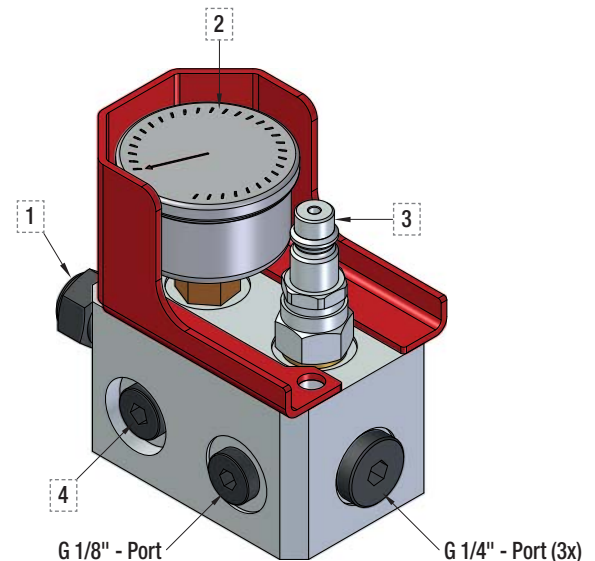
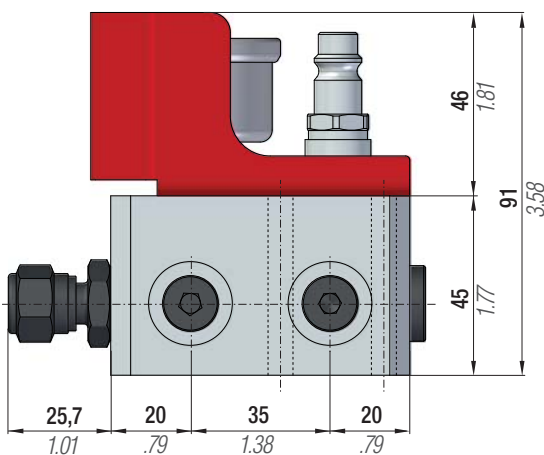
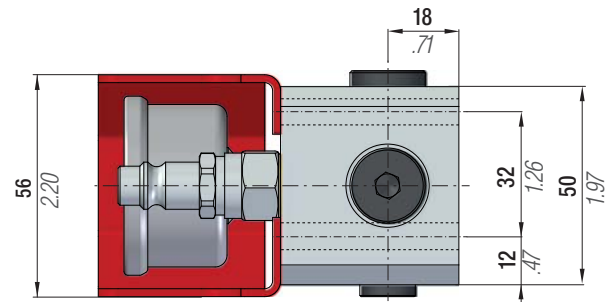
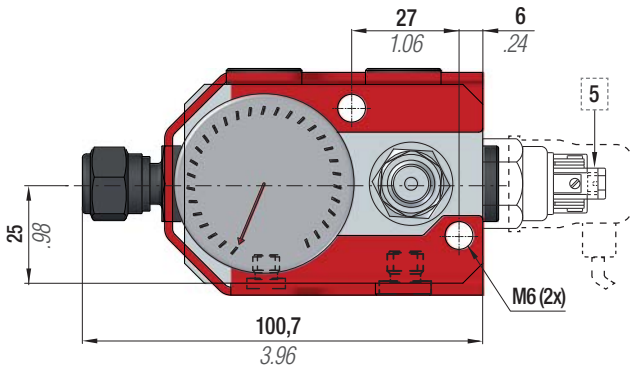

1	Valvola di scarico Discharging valve Auslaßventil Valve de déchargement Válvula de desahogo Válvula de descarga	2	Manometro 0÷ 600 bar Pressure gauge 0÷ 600 bar Manometer 0÷ 600 bar Manomètre 0÷ 600 bar Manómetro 0÷ 600 bar Manómetro 0÷ 600 bar	3	Innesto rapido di carica-mento Cejn Quick coupling for charging Cejn Steckkegel Cejn Accouplement rapide mâle Cejn Acoplamiento rápido para carga Cejn União rápida para carregamento Cejn	4	Tappo di rottura sovrappresione Over pressure rupture plug Überdruck Bruch Stecker Bouchon de rupture de surpression Enchufe de la ruptura de sobrepresión Plugue ruptura sobrepresão	5	Pressostato 50÷300 bar Pressure switch 50÷300 bar Druckwächter 50÷300 bar Pressostat 50÷300 bar Pressostato 50÷300 bar Pressostato 50÷300 bar
---	--	---	---	---	---	---	--	---	--



CONTROL PANEL CP14A ■ (Daimler standard)



<p>IT</p> <p>Pannello di controllo a standard Daimler. Base in alluminio provvisto di manometro, valvola di caricamento e scaricamento, pressostato e protezione in acciaio. 3 uscite 7/16-20UNF per gestione sistemi collegati. Può essere equipaggiato con tappo di rottura sovrappressione.</p>	<p>EN</p> <p>Control panel according to Daimler standard. Made of aluminum base. Equipped with pressure gauge, charging and discharging valve, pressure switch and steel protection. Three 7/16-20UNF gas outlets for managing hose system. It can be equipped with over pressure rupture plug.</p>	<p>DE</p> <p>Kontrollarmatur nach Daimler-Norm. Aufgebaut auf Aluminiumsockel. Manometer, Auffüll- und Ablassventil, Druckwächter und Stahlabdeckung. Drei 7/16-20UNF Gas Anschlüsse zur Steuerung der Verbundsysteme. Es kann mit Überdruck Bruch Stecker ausgestattet werden.</p>	<p>FR</p> <p>Panneau de contrôle selon le standard Daimler. Avec base en aluminium, manomètre, valve de chargement-déchargement, pressostat et protection en acier. Trois sorties 7/16-20UNF gaz pour la gestion des systèmes connectés. Il peut être équipé avec bouchon de rupture de surpression.</p>	<p>ES</p> <p>Panel de control según standard Daimler. Con base de aluminio, manómetro, válvula de carga y descarga, presostato y protección en acero. 3 salidas de 7/16-20UNF gas para gestión de sistemas conectados. Puede equiparse con enchufe de la ruptura de sobrepresión.</p>	<p>PT</p> <p>Painel de controlo de acordo com o Standard Daimler. Fabricado a partir de uma base de alumínio. Equipado com manómetro, válvula de carga e descarga, pressostato e sistema de protecção de aço. Três saída de gás 7/16-20UNF para ligação a mangueiras. Pode ser equipado com plugue ruptura sobrepresão.</p>
---	--	--	---	--	--

code	Pressure Gauge	Pressure Switch	Rupture Plug
39CP14A	bar/psi	✓	✗
39CP14A + 39DR004	bar/psi	✓	✓
39CP14A + 39TS460	bar/psi	✓	✓

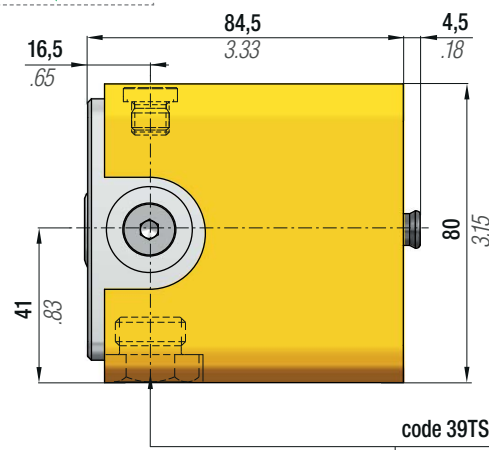
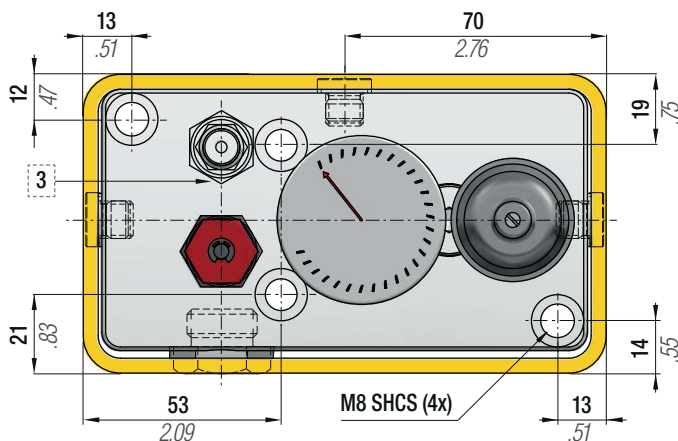

code 39TS460	5.2 - option
code 39DR004	5.1 - option
standard	5

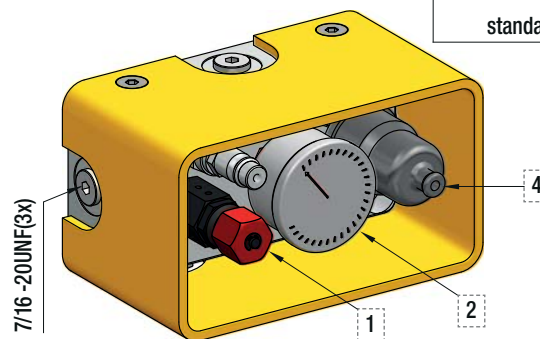
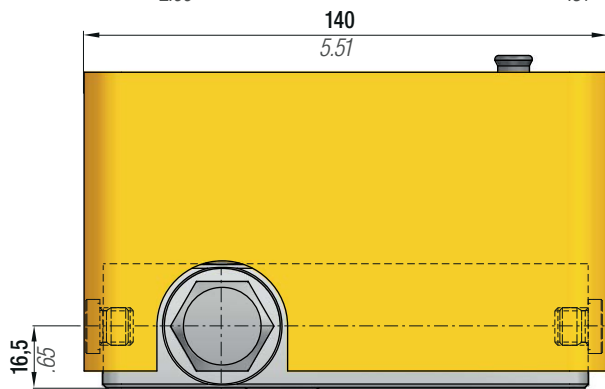

<p>1 Valvola di scarico Discharging valve Auslaßventil Valve de déchargement Válvula de desahogo Válvula de descarga</p>	<p>2 Manometro 0÷ 620 bar Pressure gauge 0÷ 620 bar Manometer 0÷ 620 bar Manomètre 0÷ 620 bar Manómetro 0÷ 620 bar Manómetro 0÷ 620 bar</p>	<p>3 Innesto rapido di caricamento Cejn Quick coupling for charging Cejn Steckkegel Cejn Accouplement rapide mâle Cejn Acoplamiento rápido para carga Cejn União rápida para carregamento Cejn</p>	<p>4 Pressostato 50÷300 bar Pressure switch 50÷300 bar Druckwächter 50÷300 bar Pressostat 50÷300 bar Presostato 50÷300 bar Pressostato 50÷300 bar</p>	<p>code: 39TS460</p>
<p>5 Tappo di chiusura M20 Closing plug M20 Verschlussstopfen M20 Bouchon de fermeture M20 Tapon de cierre M20 Plugue de fechamento M20</p>	<p>5.1 Tappo di rottura sovrappressione Over pressure rupture plug Überdruck Bruch Stecker Bouchon de rupture de surpression Enchufe de ruptura de sobrepresión Plugue ruptura sobrepresão</p>	<p>5.2 Tappo di sicurezza sovrappressione CE Overpressure safety plug CE Überdruck Sicherheitsstecker CE Bouchon de sécurité surpression CE Enchufe de seguridad sobrepresión CE Bujão de segurança sobrepresão CE</p>		

code	Pressure Gauge	Rupture Plug
39CPVD	bar/psi	✗
39CPVD + 39DR004	bar/psi	✓
39CPVD + 39TS460	bar/psi	✓

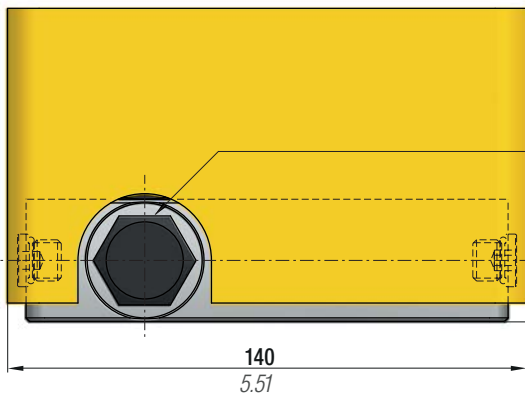
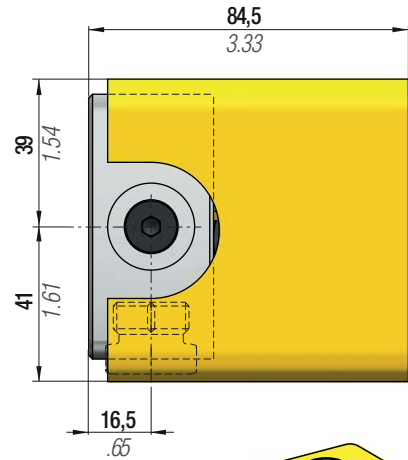
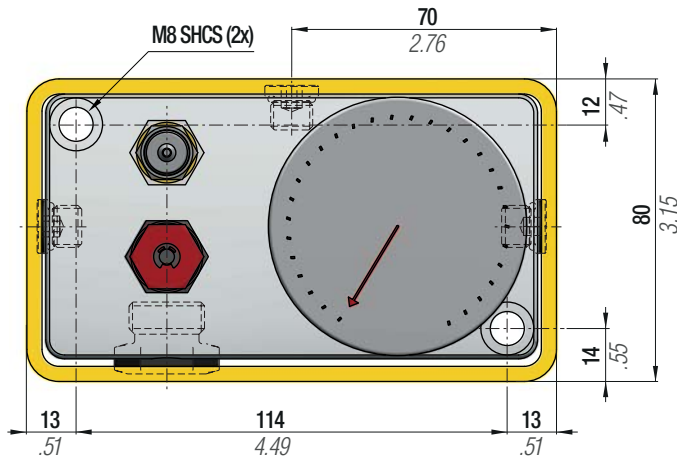

code 39TS460 4.2 - option
code 39DR004 4.1 - option
standard 4

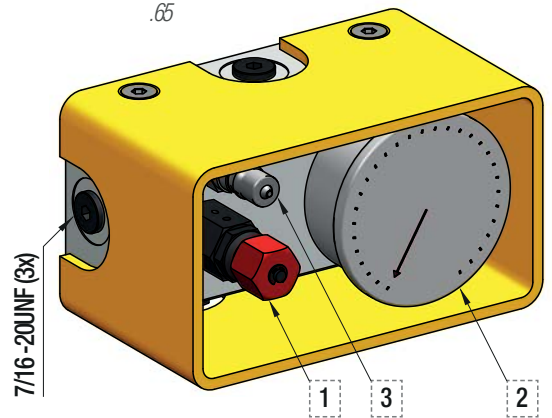

<p>1</p> <p>Valvola di scarico Discharging valve Auslaßventil Valve de déchargement Válvula de desahogo Válvula de descarga</p>	<p>2</p> <p>Manometro 0÷ 620 bar Pressure gauge 0÷ 620 bar Manómetro 0÷ 620 bar Manómetro 0÷ 620 bar Manómetro 0÷ 620 bar</p>	<p>3</p> <p>Innesto rapido per caricamento ISO7241-1 Series B Quick coupling for charging ISO7241-1 Series B Steckkegel ISO7241-1 Series B Accouplement rapide mâle ISO7241-1 Series B Acoplamiento rápido para carga ISO7241-1 Series B União rápida para carregamento ISO7241-1 Series B</p>	<p>code: 39TS460</p>
<p>4</p> <p>Tappo di chiusura M20 Closing plug M20 Verschlussstopfen M20 Bouchon de fermeture M20 Tapon de cierre M20 Plugue de fechamento M20</p>	<p>4.1</p> <p>Tappo di rottura sovrappressione Over pressure rupture plug Überdruck Bruch Stecker Bouchon de rupture de surpression Enchufe de ruptura de sobrepresión Plugue ruptura sobrepresão</p>	<p>4.2</p> <p>Tappo di sicurezza sovrappressione CE Overpressure safety plug CE Überdruck Sicherheitsstecker CE Bouchon de sécurité surpression CE Enchufe de seguridad sobrepresion CE Bujão de segurança sobrepresão CE</p>	

CONTROL PANEL CPVD (FIAT standard) - Hose connections

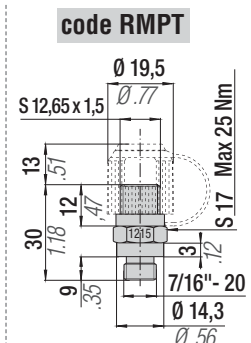
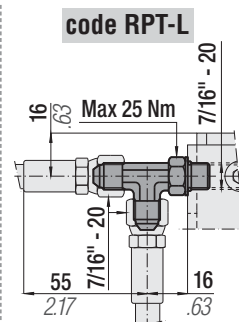
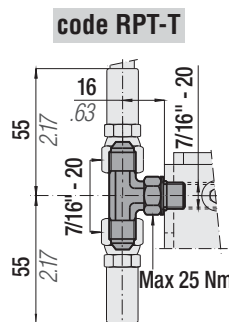
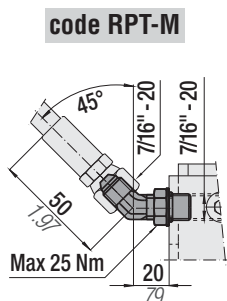
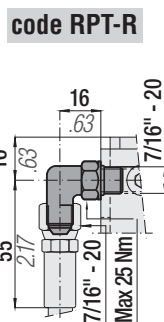
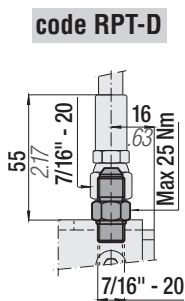

CONTROL PANEL CP15A ■



IT
Pannello di controllo con base in alluminio, provvisto di manometro, valvola di carica e protezione in acciaio. 2 uscite da 1/8" gas per gestione sistemi collegati.

EN
Control panel with aluminum base. Equipped with pressure gauge, charging valve and steel protection. Two 1/8" gas outlets for managing hose system.

DE
Kontrollarmatur mit Aluminiumsockel. Ausgestattet mit Manometer, Auffüllventil und Stahlabdeckung. Zwei 1/8" Gas Anschlüsse zur Steuerung der Verbundsysteme.

FR
Panneau de contrôle avec base en aluminium. Equipé de manomètre, valve de chargement et protection en acier. Deux sorties 1/8" gaz pour la gestion des systèmes connectés.

ES
Panel de control con base de aluminio. Equipado con manómetro, válvula de carga y protección en acero. 2 salidas de 1/8" gas para gestión de sistemas conectados.

PT
Painel de controlo com base de alumínio. Equipado com manómetro, válvula de carga e sistema de protecção de aço. Duas saídas de gás 1/8" para ligação a manguelras.

code	Pressure Gauge	Rupture Plug
39CP15A	bar/psi	X

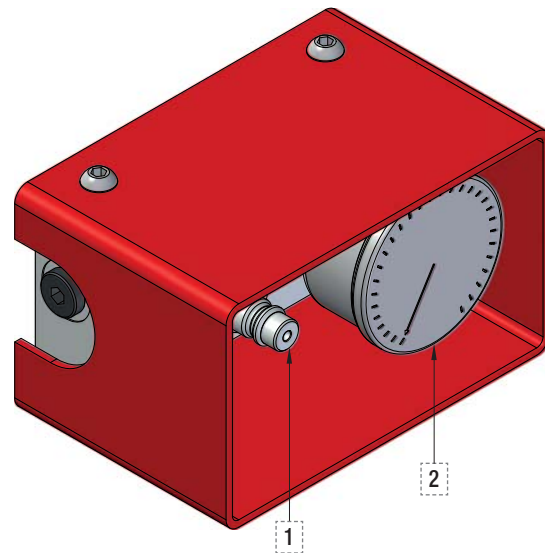
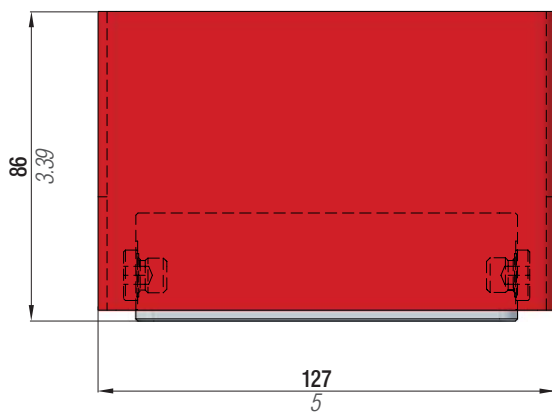
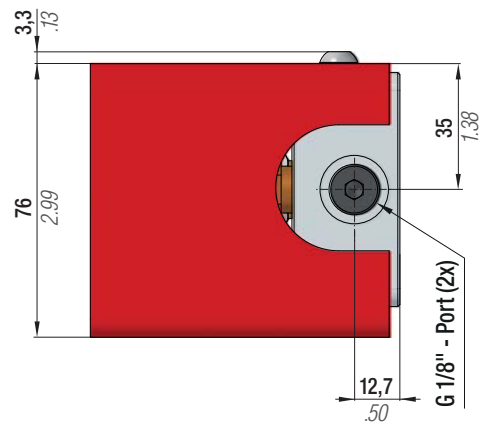
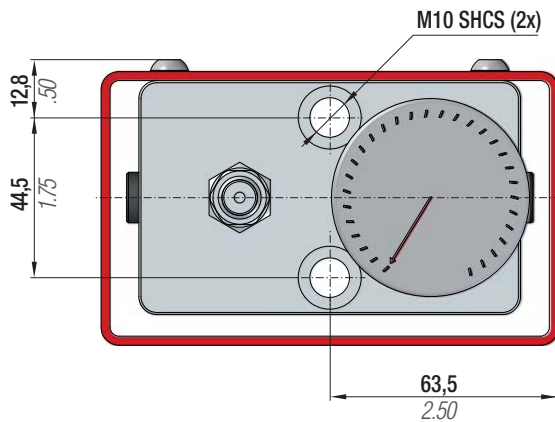

1	Innesto rapido di caricamento Cejn Quick coupling for charging Cejn Steckkegel Cejn Acoplamiento rápido para carga Cejn União rápida para carregamento Cejn	2	Manometro 0÷ 620 bar Pressure gauge 0÷ 620 bar Manometer 0÷ 620 bar Manomètre 0÷ 620 bar Manómetro 0÷ 620 bar Manómetro 0÷ 620 bar
---	---	---	---

code 39VS03A



⚠ Use only for 39CP15A

IT	Dispositivo di scaricamento
EN	Discharging device
DE	Ablassvorrichtung
FR	Dispositif de déchargement
ES	Dispositivo de descarga
PT	Dispositivo de descarga

IT

Pannello di controllo con base in alluminio, provvisto di manometro, valvola di caricamento e scaricamento, tappo di rottura sovrappressione, protezione in acciaio, 3 uscite da 1/8" gas per gestione sistemi collegati.

EN

Control panel with aluminum base. Equipped with pressure gauge, charging and discharging valve, over pressure rupture plug, steel protection, three 1/8" gas outlets for managing hose system.

DE

Kontrollarmatur mit Aluminiumsockel. Ausgestattet mit Manometer, Auffüll- und Ablassventil, Überdruck Bruch Stecker, Stahlabdeckung, drei 1/8" Gas Anschlüsse zur Steuerung der Verbundsysteme.

FR

Panneau de contrôle avec base en aluminium. Equipé de manomètre, valve de chargement-déchargement, bouchon de rupture de surpression, protection en acier, trois sorties 1/8" gaz pour la gestion des systèmes connectés.

ES

Panel de control con base de aluminio. Equipado con manómetro, válvula de carga y descarga, enchufe de la ruptura de sobrepresión, protección en acero, 3 salidas de 1/8" gas para gestión de sistemas conectados.

PT

Painel de controlo com base de alumínio. Equipado com manómetro, válvula de carga e descarga, plugue ruptura sobrepresão, sistema de protecção de aço, três saídas de gás 1/8" para ligação a mangueiras.

code	Pressure Gauge	Rupture Plug
39CP16A	bar/psi	✓

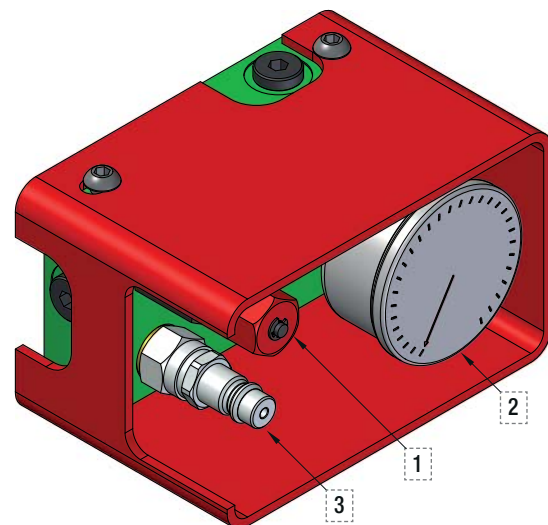
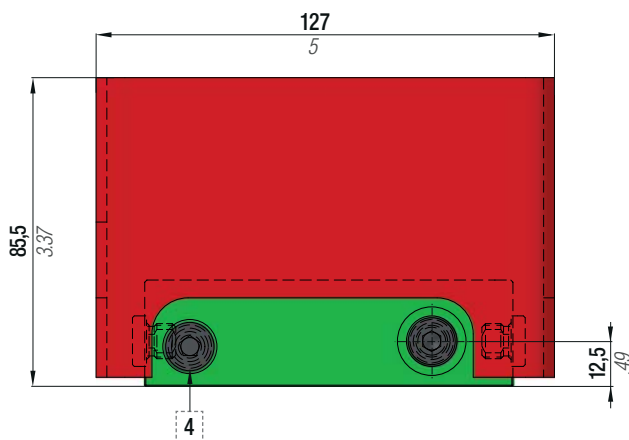
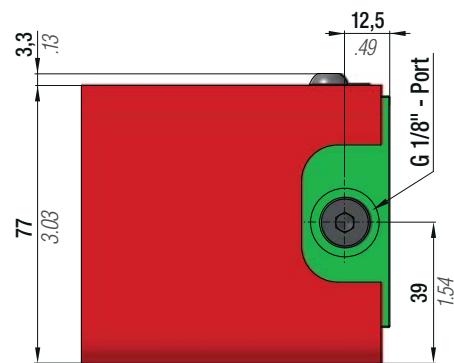
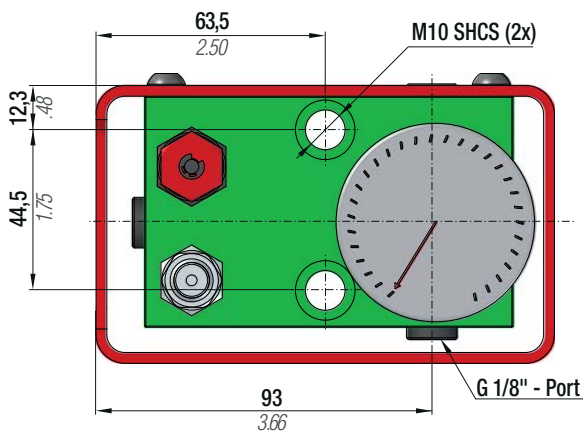

1	Valvola di scarico Discharging valve Auslaßventil Valve de déchargement Válvula de desahogo Válvula de descarga	2	Manometro 0÷ 620 bar Pressure gauge 0÷620 bar Manometer 0÷ 620 bar Manomètre 0÷ 620 bar Manómetro 0÷ 620 bar Manómetro 0÷ 620 bar	3	Innesto rapido di caricamento Cejn Quick coupling for charging Cejn Steckkegel Cejn Accouplement rapide mâle Cejn Acoplamiento rápido para carga Cejn União rápida para carregamento Cejn	4	Tappo di rottura sovrappressione Over pressure rupture plug Überdruck Bruch Stecker Bouchon de rupture de surpression Enchufe de la ruptura de sobrepresión Plugue ruptura sobrepresão
---	--	---	--	---	--	---	---



DISTRIBUTION BLOCKS



code 39BD0301A

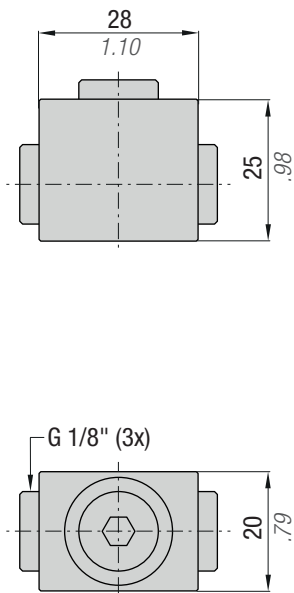

code 39BD0401A

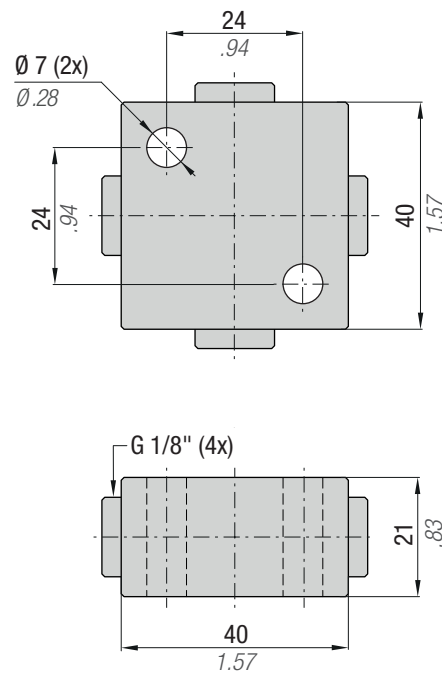

code 39BD0402A

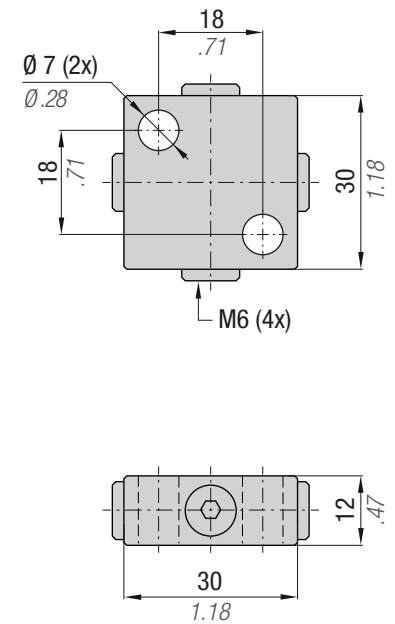

code 39BD06A

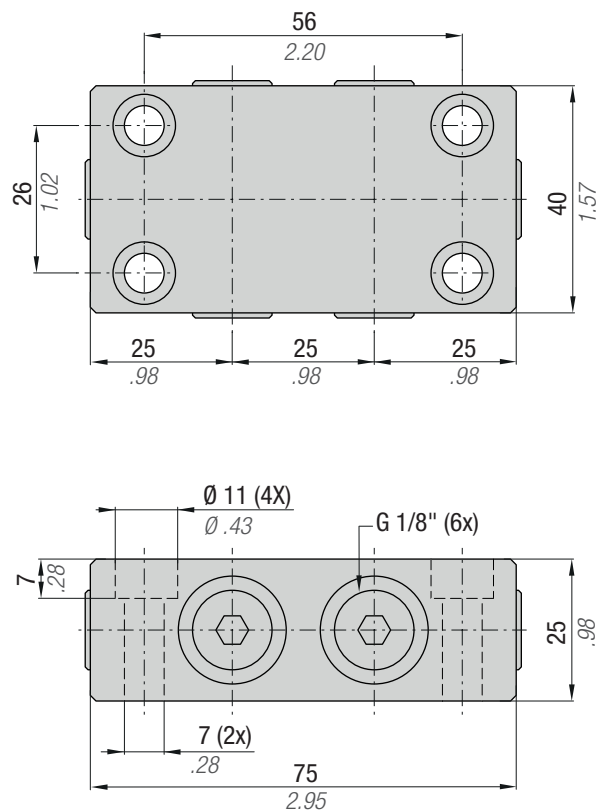

code 39BD0601A

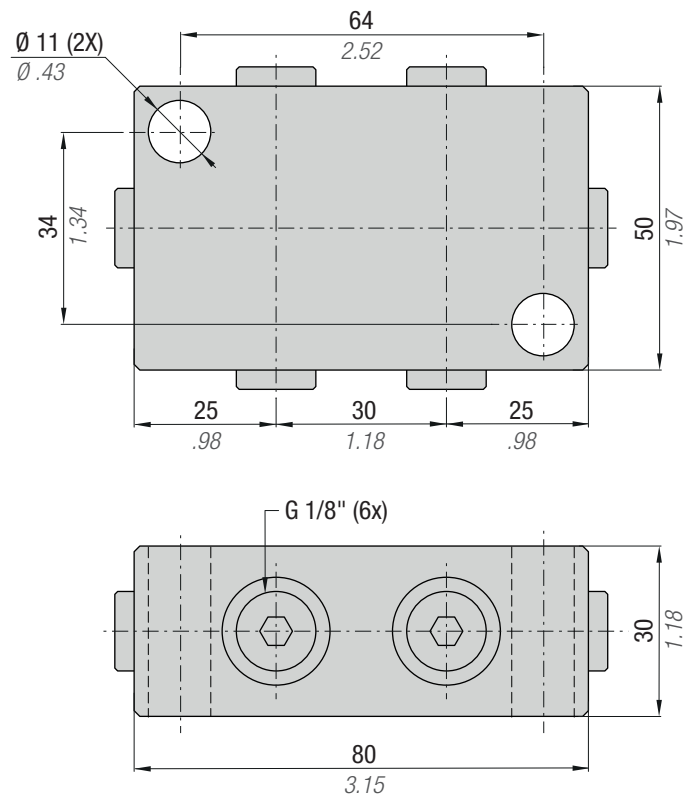

code 39BD06/1

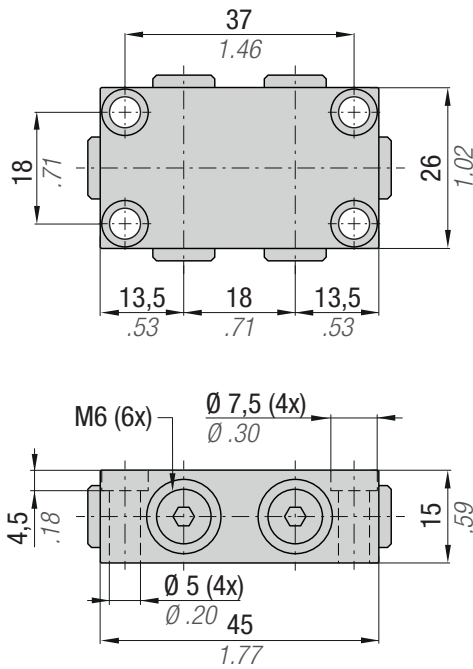

code 39BD06/2

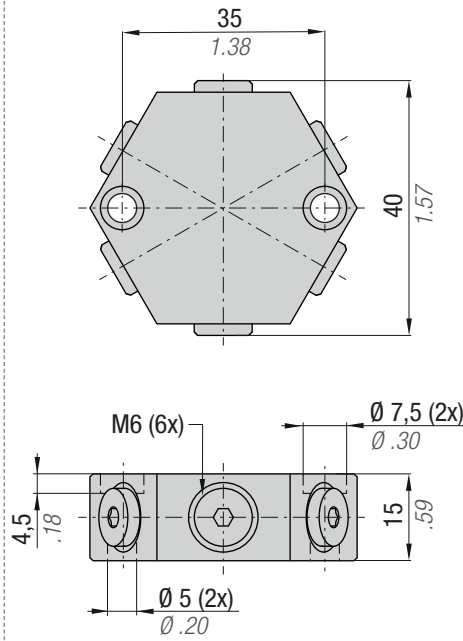

code 39BD0603A

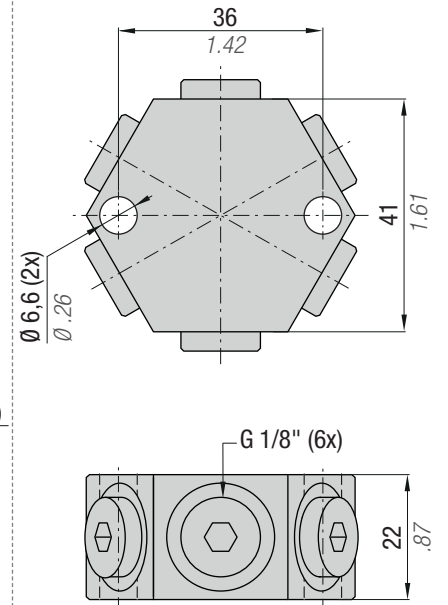

code 39BD0801A

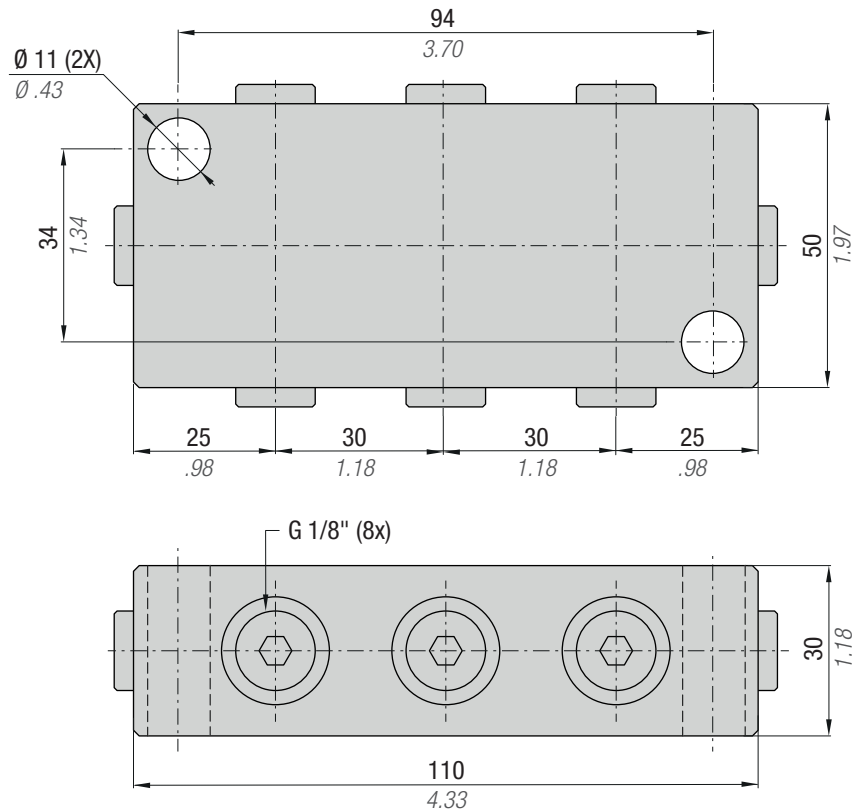

All dimensions in mm/inch



DISTRIBUTION BLOCKS



code 39BD10A

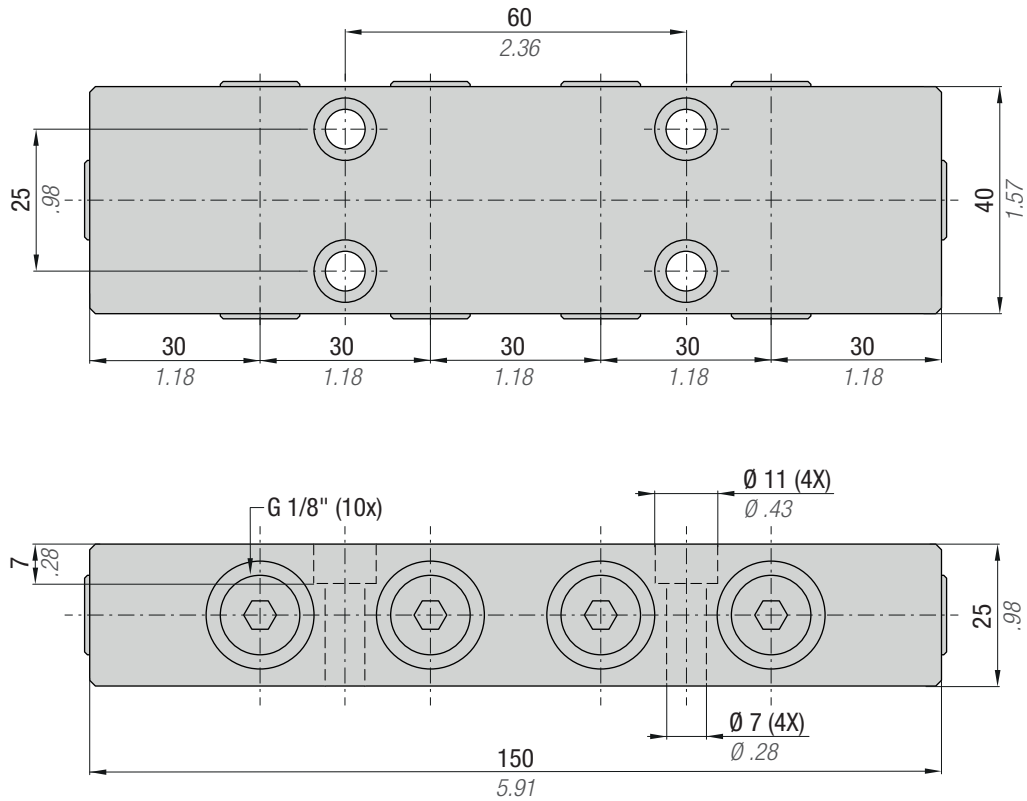

code 39BD1001A

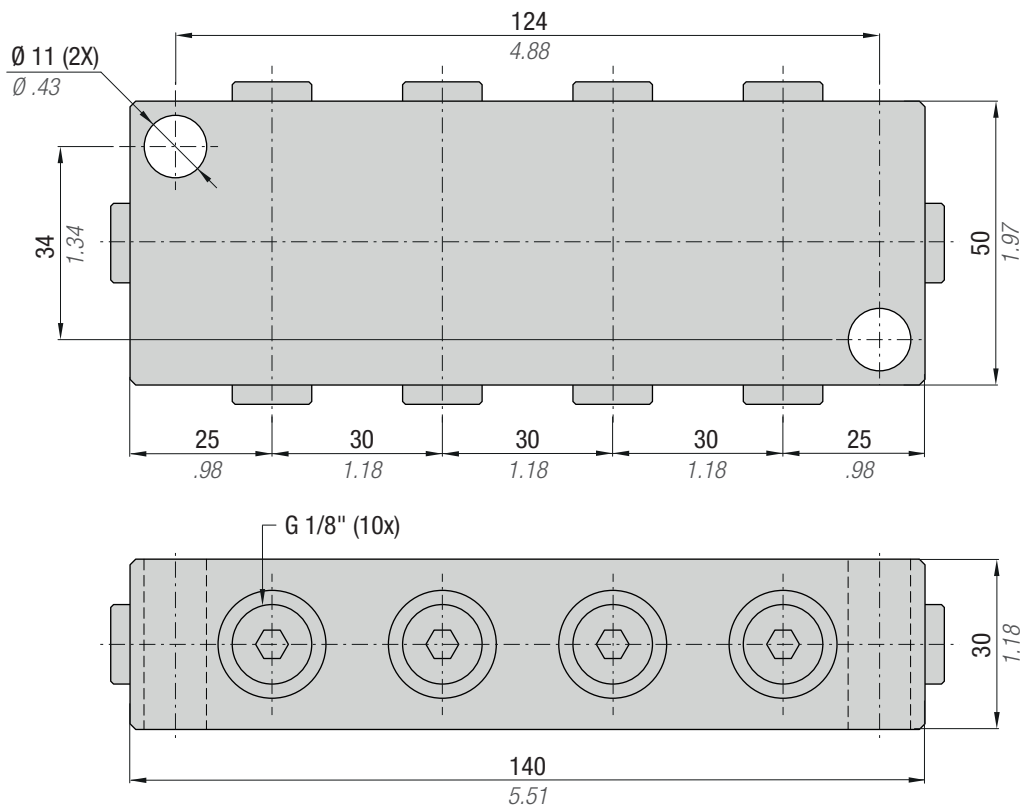

code 39BD1201A

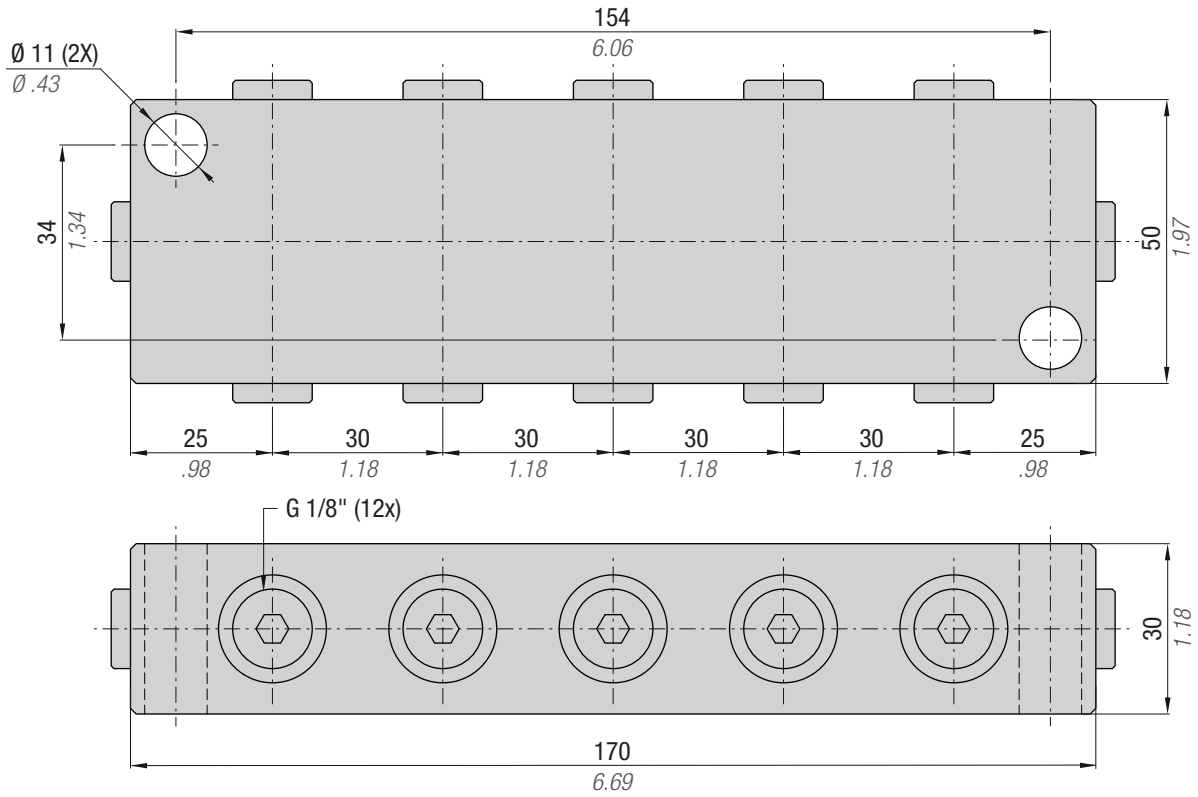

code 39BD1401A

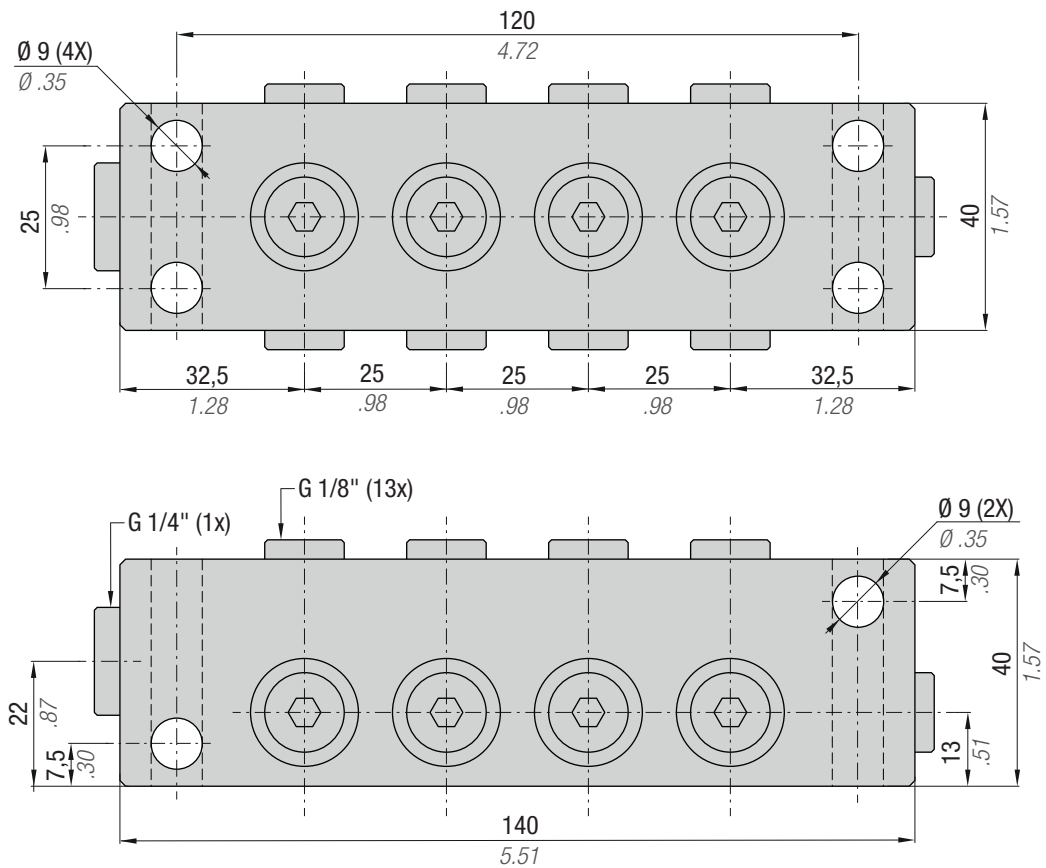

All dimensions in mm/inch

COMPENSATION TANKS



IT Nel modo di funzionamento non autonomo i cilindri possono essere collegati ad un polmone di compensazione esterno. Lo scopo principale è contenere l'aumento di pressione nel sistema entro limiti prefissati e minori rispetto al normale incremento dato dalla compressione degli steli-pistoni. La determinazione del volume di compensazione richiesto è facilmente calcolabile applicando la seguente formula:

$$V_p = n \cdot \{[S \cdot x \cdot R / (R-1)] - V_0\}$$

V_p = volume del polmone [cm³]

n = numero di cilindri componenti il sistema

S = sezione dello stelo (pistone per serie KE)
di ogni singolo cilindro [cm²]

x = corsa effettiva di lavoro [cm]

R = rapporto tra pressione finale ed iniziale del sistema [max 1,4]

V_0 = volume iniziale di ogni singolo cilindro [cm³]

Esempio:

Forza richiesta ~6000 daN ed $R=1,1$ (10%). Si scelgono n. 4 SC1500-50 (oppure n. 2 SC3000-50) Il volume richiesto è di circa 1300 cm³ e quindi la scelta sarà per il polmone tipo PC-3. Un eventuale maggior volume del polmone non è un problema. Inoltre possono essere collegati tra loro più polmoni di compensazione per ottenere volumi più prossimi a quelli richiesti

EN Gas cylinders operating in non self-contained mode may be connected to a compensation tank. The principal aim is to limit the pressure within the system to a lower figure than would normally be obtained with standard compression rates. The compensation tank volume may be easily found using the following formula:

$$V_p = n \cdot \{[S \cdot x \cdot R / (R-1)] - V_0\}$$

V_p = compensation volume [cm³]

n = no. of gas cylinders required.

S = Area of rod (piston for series KE) in [cm²]

x = effective working stroke in [cm]

R = Ratio between final required pressure and initial pressure of the system [max 1,4]

V_0 = Initial volume of each cylinder in [cm³]

Example:

Force required ~6000 daN and $R = 1,1$ (10%). No. of cylinders = 4 Type SC1500-50 (or 2 Type SC3000-50). The compensation volume required is approximately 1300 cm³. Therefore, the compensation tank required will be type PC-3. Extra volume in the tank is generally not a problem, and to obtain more accurate volume, extra tanks may be connected in the system

FR Im gesteuerten Funktionsmodus können die Zylinder an einen Ausgleichspeicher angeschlossen werden. Hauptzweck ist es, den Druckaufbau im System innerhalb der vorgegebenen Grezwerte und unter der zulässigen Zunahme durch den Druck der Kolbenstangen zu halten. Die Bestimmung des notwendigen Ausgleichsvolumens kann mit folgender Formel leicht errechnet werden:

$$V_p = n \cdot \{[S \cdot x \cdot R / (R-1)] - V_0\}$$

V_p = Speichervolumen [cm³]

n = Anzahl der Zylinder im System

S = Stangenquerschnitt (Kolben für Serie KE)
jedes einzelnen Zylinders [cm²]

x = tatsächlicher Arbeitshub [cm]

R = Verhältnis zwischen Anfangs- und Enddruck des Systems [max 1,4]

V_0 = Anfangsvolumen jedes einzelnen Zylinders [cm³]

Beispiel:

Benötigte Kraft ca. 6000 daN, $R = 1,1$ (10%) Nr. 4 SC1500-50 (oder Nr. 2 SC3000-50) Das benötigte Volumen beträgt ca. 1300 cm³, die Wahl des Speichers fällt daher auf den Typ PC-3. Auch ein eventuelles höheres Speicher volumen stellt kein Problem dar. Außerdem können mehrere Ausgleichspeicher aneinander geschlossen werden, um die benötigten Volumina zu erhalten

F Dans le mode de fonctionnement non autonome, les vérins peuvent être reliés à un réservoir de compensation.

L'objectif principal est de contenir l'élévation de la pression, dans le système, dans les limites préétablies et inférieures par rapport à l'augmentation normale provoquée par la compression des tiges-pistons.

La détermination du volume de compensation requis se calcule facilement en utilisant la formule suivante:

$$V_p = n \cdot \{[S \cdot x \cdot R / (R-1)] - V_0\}$$

V_p = volume du réservoir [cm³]

n = nombre de vérins composant le système

S = section de la tige (piston pour série KE)
de chaque vérin [cm²]

x = course réelle de travail [cm]

R = rapport entre pression finale et initiale du système [max 1,4]

V_0 = volume initial de chaque vérin [cm³]

Exemple:

Force requise env. 6000 daN et $R = 1,1$ (10%) 4 SC1500-50 (ou bien 2 SC3000-50) Le volume requis est d'environ 1300 cm³ et le choix se portera donc sur le réservoir de type PC-3. A noter qu'un plus grand volume éventuel du réservoir ne représente pas un problème. De plus, les réservoirs peuvent être couplés pour obtenir les volumes voisinant ceux requis.

ES Los cilindros de gas en funcionamiento no autónomo pueden conectarse a un pulmón de compensación. El objetivo principal es limitar la presión del sistema, reduciéndola a un valor menor que el que normalmente se obtendría con tasas de compresión standard. El volumen del pulmón de compensación puede calcularse fácilmente mediante la siguiente fórmula:

$$V_p = n \cdot \{ [S \cdot x \cdot R / (R-1)] - V_0 \}$$

V_p = volumen de compensación [cm³]

n = nº de cilindros de gas necesarios.

S = Área del vástago (pistón en la serie KE) en [cm²]

x = carrera efectiva en [cm]

R = Cociente entre la presión final necesaria y la presión inicial del sistema max 1,4

V_0 = Volumen inicial de cada cilindro en [cm³]

Ejemplo:

Fuerza necesaria ~6000 daN y $R = 1,1$ (10%).

Nº de cilindros = 4 Tipo SC1500-50 (ó 2 Tipo SC3000-50). El volumen de compensación necesario es de aproximadamente 1300 cm³.

Por lo tanto, el pulmón de compensación será del tipo PC-3. Por lo general, un pulmón con volumen extra no constituye problema. Para obtener un volumen más exacto, puede ser necesario conectar más pulmones al sistema

PT Os cilindros de gás que operam em modo não autónomo podem ser ligados a um depósito de compensação. O principal objectivo é limitar o aumento de pressão dentro do sistema a um valor inferior ao que se obteria normalmente com taxas de compressão normalizadas. O volume do depósito de compensação pode ser facilmente determinado utilizando a fórmula seguinte:

$$V_p = n \cdot \{ [S \cdot x \cdot R / (R-1)] - V_0 \}$$

V_p = volume de compensação [cm³]

n = nº de cilindros de gás necessários.

S = Área do embolo (pistão para a série KE) em [cm²]

x = curso de trabalho efectivo em [cm]

R = Relação entre a pressão final requerida e a pressão inicial do sistema [max 1,4]

V_0 = Volume inicial de cada cilindro em [cm³]

Exemplo:

Força requerida ~6000 daN e $R = 1,1$ (10%).

Nº de cilindros = 4 Tipo SC1500-50 (ou 2 Tipo SC3000-50). O volume de compensação requerido é de aproximadamente 1300 cm³. Logo, o depósito de compensação requerido é do tipo PC-3. O volume suplementar no depósito não é geralmente um problema e, para obter um volume mais preciso, podem ser ligados ao sistema depósitos suplementares

Codice Code Bestallnr. Code Codigo Código	Ø D		L		A		H		HT		B		Faccia X X Side Seite X Face X Cara X Face X	Faccia Y Y Side Seite Y Face Y Cara Y Face Y	C	Raccordi Fittings Anschlüsse Raccords Racores Ligações	Volume Volume Volumen Volume Volumen Volume		PED 2014/68/EU	
	mm	inch	mm	inch	mm	inch	mm	inch	mm	inch	mm	inch					cm ³	in ³		
39PC001A	100	3.94	290	11.42	90	3.54	58	2.28	140	5.51	125	4.20	G1/8" (3x)	G1/8" (4x)	40	1.57		1000	61.02	✓
39PC003A	150	5.91	310	12.20	136	5.35	83	3.27	190	7.48	172	6.77	G1/8" (4x)	G1/8" (4x)	70	2.76	RTC	3000	183.07	✓
39PC005A	150	5.91	475	18.70	136	5.35	83	3.27	190	7.48	172	6.77	G1/8" (4x)	G1/8" (4x)	70	2.76	RMTC	5000	305.12	✓
39PC008A	200	7.87	415	16.34	212	8.35	108	4.25	242	9.53	252	9.92	G1/8" (6x)	G1/8" (6x)	97	3.82	RSMPTD	8000	488.18	✓
39PC010A	200	7.87	505	19.88	212	8.35	108	4.25	242	9.53	252	9.92	G1/8" (6x)	G1/8" (6x)	97	3.82		9960	607.79	✓

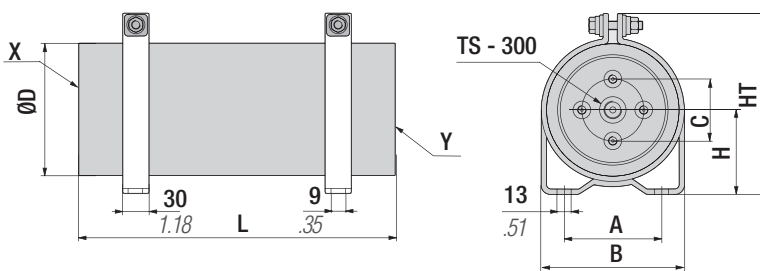

code: TS - 300 (300 bar)

Tappo di sicurezza sovrappressione CE
Overpressure safety plug CE
Überdruck Sicherheitsstecker CE
Bouchon de sécurité surpression CE
Enchufe de seguridad sobrepresion CE
Bujão de segurança sobrepresão CE

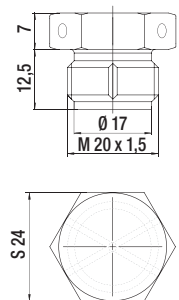

Esempio - Example - Beispiel - Exemple - Ejemplo - Exemplo:

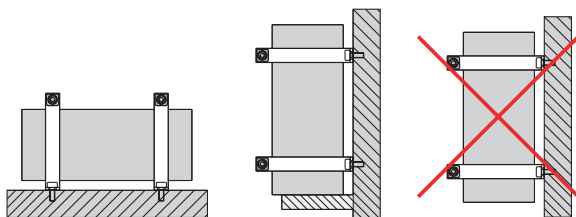

IT Pressione massima di caricamento: P= 150 bar

EN Maximum charging pressure: P= 150 bar

DE Max. Fülldruck: P= 150 bar

FR Pression maximale: P= 150 bar

ES Presión máxima de carga P = 150 bar

PT Pressão máxima de carregamento: P= 150 bar



All dimensions in mm/inch

AIR SYSTEMS TANKS



- IT** Le tabelle sotto riportate devono essere utilizzate, in fase di progettazione, per determinare il numero, il volume e le dimensioni dei serbatoi aria a bordo stampi. Tabella volumi (litri): volume d'aria necessario per cilindro pneumatico in relazione al diametro e alla corsa.
- EN** The tables below must be used, during design, to define the number, volume and sizes of the air tanks on the dies. Volume table (litres): volume of air needed for the pneumatic cylinder in relation to the diameter and stroke.
- DE** Die untenstehenden Tabellen werden in der Planungsphase für die Bestimmung der Anzahl, des Volumens und der Abmessung der Luftbehälter an Bord der Formen benutzt. Tabelle der Volumen (Liter): Das für Pneumatikzylinder in Bezug auf Durchmesser und Hub notwendige Luftvolumen
- FR** Les tableaux reportés ci-dessous doivent être utilisés, lors de la conception, pour déterminer le nombre, le volume et les dimensions des réservoirs d'air sur le bord des moules. Tableau des volumes (litres) : volume d'air nécessaire par cylindre pneumatique par rapport au diamètre et à la course.
- ES** Las tablas propuestas abajo deben ser utilizadas, en la fase de diseño, para determinar el número, el volumen y las dimensiones de los tanques de aire al borde de moldes. Tabla de volúmenes (litros): volumen de aire necesario para cilindro neumático en relación al diámetro y a la carrera.
- PT** As tabelas abaixo devem ser usadas na fase de design de forma a determinar o número, o volume e o tamanho do reservatório de ar da ferramenta.

Cilindro pneumatico Pneumatic cylinder Pneumatikzylinder Vérin pneumatique Cilindro neumático Cilindro pneumático mm inch		Corse standard - Standard Strokes - Standardhöhe - Course standard - Carreras estándar - Cursos standard mm inch																	
		25	0.98	40	1.57	50	1.97	60	2.36	75	2.95	100	3.94	125	4.92	150	5.91	175	6.89
		Volume - Volume - Volumens - Volume - Volumen - Volume dm ³ in ³																	
Ø 32	Ø 1.26	0,020	1.220	0,032	1.953	0,040	2.441	0,048	2.929	0,060	3.661	0,080	4.882	0,100	6.102	0,120	7.323	0,140	8.543
Ø 40	Ø 1.57	0,031	1.892	0,050	3.051	0,063	3.844	0,075	4.577	0,094	5.736	0,126	7.689	0,157	9.581	0,189	11.533	0,221	13.486
Ø 50	Ø 1.97	0,049	2.990	0,078	4.760	0,098	5.980	0,118	7.201	0,147	8.970	0,196	11.961	0,245	14.951	0,294	17.941	0,343	20.931
Ø 63	Ø 2.48	0,078	4.760	0,125	7.628	0,158	9.642	0,187	11.411	0,234	14.280	0,312	19.039	0,390	23.799	0,488	29.780	0,546	33.319
Ø 80	Ø 3.15	0,126	7.689	0,201	12.266	0,251	15.317	0,302	18.429	0,377	23.006	0,503	30.700	0,528	32.221	0,754	46.012	0,880	53.701
Ø 100	Ø 3.94	0,196	11.961	0,314	19.161	0,393	23.982	0,471	28.742	0,589	35.943	0,785	47.904	0,982	59.925	1,177	71.825	1,374	83.847
Ø 125	Ø 4.92	0,308	18.795	0,491	29.963	0,614	37.469	0,738	45.036	0,920	56.142	1,227	74.876	1,534	93.610	1,841	112.34	2,147	131.02
Ø 160	Ø 6.30	0,502	30.634	0,804	49.063	1,005	61.329	1,208	73.717	1,508	92.024	2,010	122.66	2,513	153.35	3,016	184.05	3,519	214.74
Ø 200	Ø 7.87	0,785	47.904	1,257	76.707	1,571	95.868	1,885	115.03	2,356	143.77	3,142	191.74	3,928	239.70	4,712	287.54	5,498	335.51

- IT** Per cilindri pneumatici funzionanti a doppio effetto (d.e.) determinare il volume attraverso la tabella. Per cilindri pneumatici funzionanti a semplice effetto (s.e.) determinare sempre il volume tramite la tabella e moltiplicare il risultato ottenuto per 3. Sommare tutti i volumi dei vari cilindri pneumatici a bordo stampo per ricavare la capacità totale (dm³) del serbatoio. Scegliere il serbatoio in relazione alla capacità totale ricavata (dm³) ed allo spazio disponibile sullo stampo.
- EN** For double acting pneumatic cylinders (d.e.) use the table to define the volume. For single-acting pneumatic cylinders (s.e.) still use the table to define the volume and multiply the result obtained by 3. Add all the volumes of the various pneumatic cylinders on the die to obtain the total capacity (dm³) of the tank. Choose the tank in relation to the total capacity obtained (dm³) and to the space available on the die.
- DE** Für Pneumatikzylinder mit Doppelleffekt (d.e.) wird das Volumen auf Grund der Tabelle bestimmt. Für Pneumatik Zylindern mit Einzeleffekt (s.e.), immer das Volume aufgrund der Tabelle bestimmen, dann der Ergebnis bei 3 multiplizieren. Aller Volumen der verschiedene Pneumatik Zylindern außer der Form summen, um das totale Fassungsvermögen des Tanks (dm³) zu ergeben. Der Tankbehälter in Verbindung mit der bestimmte Fassungsvermögen (dm³), und mit dem verfügbare Raum auf der Form, auszuwählen.
- FR** Pour les cylindres pneumatiques fonctionnant à double effet (d.e.), déterminer le volume au moyen du tableau. Pour les cylindres pneumatiques fonctionnant à effet simple (s.e.), déterminer toujours le volume au moyen du tableau et multiplier le résultat obtenu par 3. Sommer tous les volumes des différents cylindres pneumatiques sur le bord du moule pour obtenir la capacité totale (dm³) du réservoir. Choix du réservoir par rapport à la capacité totale obtenue (dm³) et à l'espace disponible sur le moule.
- ES** Para cilindros neumáticos funcionantes a doble efecto (d. e.) determinar el volumen por medio de la tabla. Para cilindros neumáticos funcionantes a simple efecto (s. e.) determinar siempre el volumen por medio de la tabla y multiplique el resultado obtenido por 3. Sumar todos los volúmenes de los varios cilindros neumáticos en el borde de la prensa para calcular la capacidad total (dm³) del depósito. Selección del tanque en relación a la capacidad total relevada (dm³) y a el espacio disponible en la prensa.
- PT** Para cilindros pneumáticos de duplo efeito (d.e), o volume deve ser determinado de acordo com a tabela. Para cilindros pneumáticos de efeito único, o volume deve ser determinado de acordo com a mesma tabela. o resultado deve ser multiplicado por 3. Para saber a capacidade total (litros) do reservatório, deve somar todos os volumes dos cilindros pneumáticos. A escolha da capacidade do reservatório, está relacionada com o cálculo da capacidade total (litros) e o espaço disponível na ferramenta.

All dimensions in mm/inch

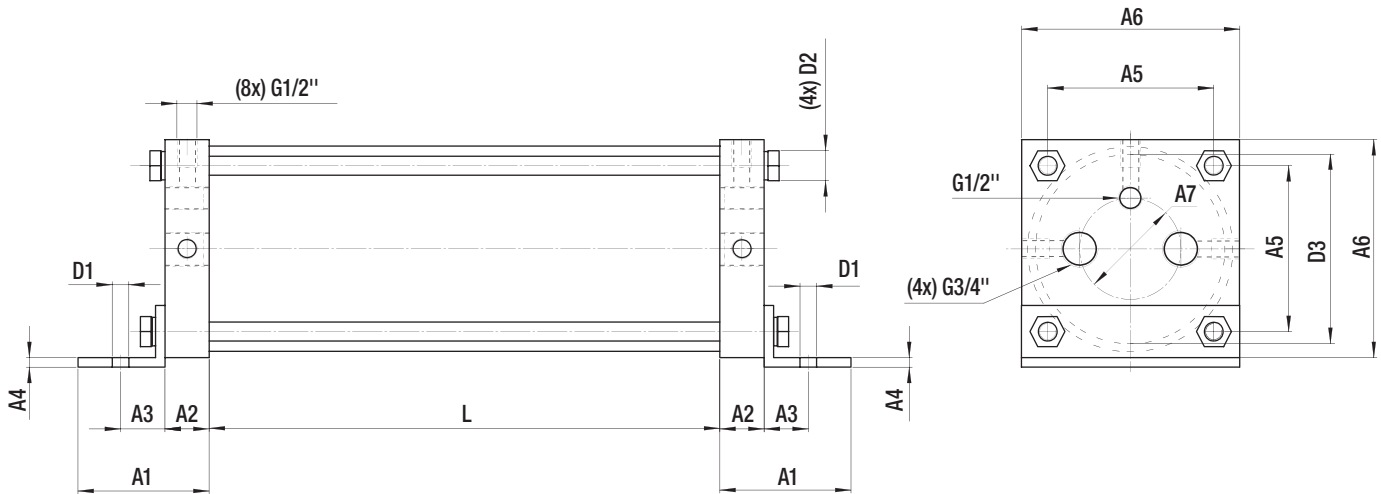

Codice Code Bestallnr. Code Codigo Código	Volume		A1		A2		A3		A4		A5		A6		A7		D1		D2		D3		L		Peso Weight Gewicht Poids Peso Peso		PED 2014/68/EU
	dm ³	in ³	mm	inch	mm	inch	mm	inch	mm	inch	mm	inch	mm	inch	mm	inch	mm	inch	mm	inch	mm	inch	mm	inch	~Kg	~lb	
39SRA1003A	3	0,12	83	3,27	28	1,10	34	1,34	6	,24	105	4,13	138	5,43	65	2,56	10,5	,41	M12	120	4,72	271	10,67	14	30,9	✓	
39SRA1004A	4	0,16	83	3,27	28	1,10	34	1,34	6	,24	105	4,13	138	5,43	65	2,56	10,5	,41	M12	120	4,72	360	14,17	15,7	34,6	✓	
39SRA1005A	5	0,20	83	3,27	28	1,10	34	1,34	6	,24	105	4,13	138	5,43	65	2,56	10,5	,41	M12	120	4,72	449	17,68	17,4	38,4	✓	
39SRA1006A	6	0,24	83	3,27	28	1,10	34	1,34	6	,24	105	4,13	138	5,43	65	2,56	10,5	,41	M12	120	4,72	538	21,18	19,1	42,1	✓	
39SRA1008A	8	0,31	83	3,27	28	1,10	34	1,34	6	,24	105	4,13	138	5,43	65	2,56	10,5	,41	M12	120	4,72	716	28,19	22,5	49,6	✓	
39SRA2003A	3	0,12	83	3,27	28	1,10	34	1,34	6	,24	127	5,00	168	6,61	80	3,15	12,5	,49	M12	150	5,91	175	6,89	17,2	37,9	✓	
39SRA2004A	4	0,16	83	3,27	28	1,10	34	1,34	6	,24	127	5,00	168	6,61	80	3,15	12,5	,49	M12	150	5,91	232	9,13	18,4	40,6	✓	
39SRA2005A	5	0,20	83	3,27	28	1,10	34	1,34	6	,24	127	5,00	168	6,61	80	3,15	12,5	,49	M12	150	5,91	289	11,38	19,7	43,4	✓	
39SRA2006A	6	0,24	83	3,27	28	1,10	34	1,34	6	,24	127	5,00	168	6,61	80	3,15	12,5	,49	M12	150	5,91	346	13,62	21,0	46,3	✓	
39SRA2008A	8	0,31	83	3,27	28	1,10	34	1,34	6	,24	127	5,00	168	6,61	80	3,15	12,5	,49	M12	150	5,91	460	18,11	23,6	52,0	✓	
39SRA2010A	10	0,39	83	3,27	28	1,10	34	1,34	6	,24	127	5,00	168	6,61	80	3,15	12,5	,49	M12	150	5,91	574	22,60	26,2	57,8	✓	
39SRA2012A	12	0,47	83	3,27	28	1,10	34	1,34	6	,24	127	5,00	168	6,61	80	3,15	12,5	,49	M12	150	5,91	688	27,09	28,7	63,3	✓	
39SRA3004A	4	0,16	83	3,27	28	1,10	34	1,34	6	,24	163	6,42	218	8,58	120	4,72	12,5	,49	M16	200	7,87	132	5,20	26,3	58,0	✓	
39SRA3005A	5	0,20	83	3,27	28	1,10	34	1,34	6	,24	163	6,42	218	8,58	120	4,72	12,5	,49	M16	200	7,87	164	6,46	27,3	60,2	✓	
39SRA3006A	6	0,24	83	3,27	28	1,10	34	1,34	6	,24	163	6,42	218	8,58	120	4,72	12,5	,49	M16	200	7,87	196	7,72	28,3	62,4	✓	
39SRA3008A	8	0,31	83	3,27	28	1,10	34	1,34	6	,24	163	6,42	218	8,58	120	4,72	12,5	,49	M16	200	7,87	260	10,24	30,3	66,8	✓	
39SRA3010A	10	0,39	83	3,27	28	1,10	34	1,34	6	,24	163	6,42	218	8,58	120	4,72	12,5	,49	M16	200	7,87	324	12,76	32,4	71,4	✓	
39SRA3012A	12	0,47	83	3,27	28	1,10	34	1,34	6	,24	163	6,42	218	8,58	120	4,72	12,5	,49	M16	200	7,87	388	15,28	34,4	75,8	✓	
39SRA3015A	15	0,59	83	3,27	28	1,10	34	1,34	6	,24	163	6,42	218	8,58	120	4,72	12,5	,49	M16	200	7,87	484	19,06	37,4	82,5	✓	
39SRA3018A	18	0,71	83	3,27	28	1,10	34	1,34	6	,24	163	6,42	218	8,58	120	4,72	12,5	,49	M16	200	7,87	580	22,83	40,4	89,0	✓	
39SRA3022A	22	0,87	83	3,27	28	1,10	34	1,34	6	,24	163	6,42	218	8,58	120	4,72	12,5	,49	M16	200	7,87	708	27,87	44,4	97,9	✓	



50°C	122°F	Temperatura max esercizio - Max. operating temperature - max. Betriebstemperatur Température maximum de fonctionnement - Temperatura máx. de ejercicio - Temepratura Max operacional.
15 bar	218 psi	P. max esercizio - Maximum operating pressure - max: Betriebsdruck Pression Max de Fonctionnement - Presión máx de ejercicio - Pressão máxima de operação.
25 bar	363 psi	Pressione di collaudo - Testing pressure - Druckprüfung Pression d'essais - Probar la presión - Pressão de teste.

All dimensions in mm/inch

ACCESSORIES



IT	Piastra di contrasto	Temperato
EN	Counter plate	Hardened
DE	Stellplatten	Gehärtet
FR	Plaques d'appui	Tempéré
ES	Placas de soporte	Templado
PT	Placas de apoi	Temperado

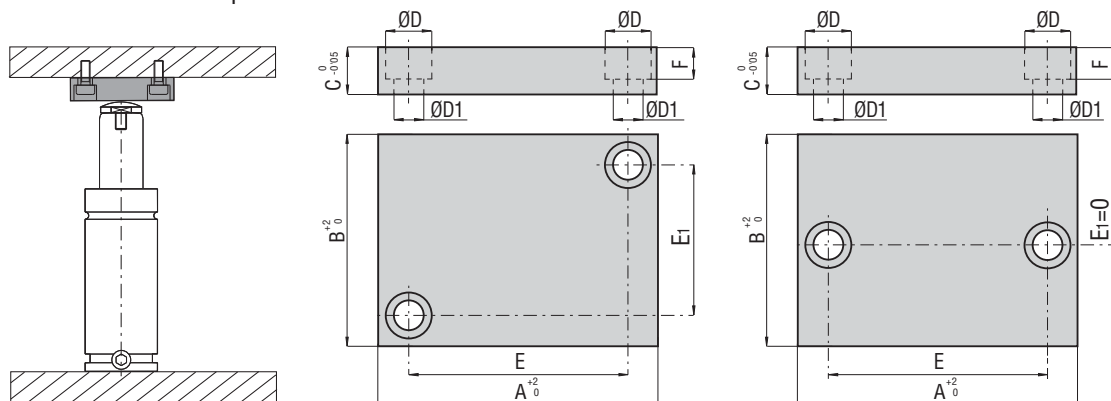

CODE		A		B		C		ØD		ØD1		E		E1		F			
PHASING OUT	NEW	mm	inch	mm	inch	mm	inch	mm	inch	mm	inch	mm	inch	mm	inch	mm		inch	
PS040040	39PA040040A ¹⁾⁵⁾	40	1.57	40	1.57	15	0.59	15	0.59	9	0.35	21	0.83	21	0.83	10	0.39	d ≤ 20	0.79
	39PAB040040A ⁴⁾⁷⁾	40	1.57	40	1.57	12	0.47	11	0.43	7	0.28	24	0.94	24	0.94	7	0.28	d ≤ 20	0.79
-	39PAA040040A	40	1.57	40	1.57	15	0.59	11	0.43	7	0.28	24	0.94	24	0.94	7	0.28	d ≤ 20	0.79
PS056056	39PA056056A ³⁾⁵⁾	56	2.20	56	2.20	20	0.79	18	0.71	11	0.43	32	1.26	32	1.26	13	0.51	d ≤ 36	1.42
	39PA060060A ⁴⁾⁷⁾	60	2.36	60	2.36	15	0.59	15	0.59	9	0.35	40	1.57	40	1.57	9	0.35	d ≤ 36	1.42
	39PAA060060A ⁶⁾	60	2.36	60	2.36	12	0.47	14	0.55	9	0.35	38	1.5	38	1.5	9	0.35	d ≤ 36	1.42
-	39PA070070A ¹⁾⁴⁾⁷⁾	70	2.76	70	2.76	15	0.59	15	0.59	9	0.35	50	1.97	50	1.97	9	0.35	d ≤ 60	2.36
PS071071	39PA071071A ⁵⁾	71	2.80	71	2.80	20	0.79	18	0.71	11	0.43	48	1.89	48	1.89	13	0.51	d ≤ 60	2.36
-	39PA080080A ²⁾	80	3.15	80	3.15	16	0.63	15	0.59	9	0.35	62	2.44	0	0	10	0.39	d ≤ 65	2.56
-	39PAB090090A	90	3.54	90	3.54	12	0.47	15	0.59	9	0.35	64	2.52	64	2.52	9	0.35	d ≤ 80	3.15
-	39PAA090090A ¹⁾	90	3.54	90	3.54	15	0.59	15	0.59	9	0.35	70	2.76	70	2.76	9	0.35	d ≤ 80	3.15
-	39PA090090A ²⁾³⁾⁵⁾	90	3.54	90	3.54	20	0.79	18	0.71	11	0.43	67	2.64	67	2.64	13	0.51	d ≤ 80	3.15
	39PAC090090A ⁶⁾	90	3.54	90	3.54	12	0.47	14	0.55	9	0.35	70	2.76	70	2.76	9	0.35	d ≤ 80	3.15
-	39PA100100A ²⁾	100	3.94	100	3.94	16	0.63	15	0.59	9	0.35	82	3.23	0	0	10	0.39	d ≤ 90	3.54
	39PAA100100A ⁴⁾⁷⁾	100	3.94	100	3.94	20	0.79	18	0.71	11	0.43	74	2.91	74	2.91	11	0.43	d ≤ 90	3.54
	39PAB100100A ⁶⁾	100	3.94	100	3.94	12	0.47	14	0.55	9	0.35	81	3.19	81	3.19	9	0.35	d ≤ 90	3.54
	39PAA140140A ⁴⁾	140	5.51	140	5.51	20	0.79	18	0.71	11	0.43	110	4.33	110	4.33	11	0.43	d ≤ 130	5.12
-	39PA140140A ³⁾⁵⁾	140	5.51	140	5.51	20	0.79	18	0.71	11	0.43	110	4.33	110	4.33	13	0.51	d ≤ 130	5.12
PS050025	39PA050025A ¹⁾⁵⁾	50	1.97	25	0.98	12	0.47	11	0.43	7	0.28	32	1.26	8	0.31	8	0.31	d ≤ 15	0.59
	39PA050030A ⁵⁾	50	1.97	30	1.18	12	0.47	11	0.43	7	0.28	40	1.57	14	0.55	8	0.31	d ≤ 20	0.79
PS055030	39PA055030A ¹⁾	55	2.17	30	1.18	12	0.47	11	0.43	7	0.28	40	1.57	14	0.55	8	0.31	d ≤ 20	0.79
-	39PA055032A ²⁾	55	2.17	32	1.26	16	0.63	15	0.59	9	0.35	37	1.46	0	0	10	0.39	d ≤ 20	0.79
-	39PA065050A ²⁾	65	2.56	50	1.97	16	0.63	15	0.59	9	0.35	47	1.85	0	0	10	0.39	d ≤ 36	1.42
PS070035	39PA070035A ¹⁾⁵⁾	70	2.76	35	1.38	15	0.59	15	0.59	9	0.35	48	1.89	14	0.55	10	0.39	d ≤ 30	1.18
PS075050	39PA075050A ¹⁾⁵⁾	75	2.95	50	1.97	15	0.59	15	0.59	9	0.35	56	2.2	30	1.18	10	0.39	d ≤ 36	1.42
-	39PA080060A ²⁾	80	3.15	60	2.36	16	0.63	15	0.59	9	0.35	62	2.44	0	0	10	0.39	d ≤ 55	2.17
-	39PAA085060A ⁵⁾	85	3.35	60	2.36	15	0.59	15	0.59	9	0.35	56	2.2	40	1.57	10	0.39	d ≤ 55	2.17
PS085060	39PA085060A ¹⁾	85	3.35	60	2.36	15	0.59	15	0.59	9	0.35	66	2.6	40	1.57	10	0.39	d ≤ 55	2.17
PS100080	39PA100080A ¹⁾⁵⁾	100	3.94	80	3.15	20	0.79	18	0.71	11	0.43	72	2.83	56	2.2	12	0.47	d ≤ 70	2.76
PS110100	39PA110100A ⁵⁾	110	4.33	100	3.94	20	0.79	18	0.71	11	0.43	85	3.35	75	2.95	12	0.47	d ≤ 100	3.94

¹⁾ VDI 3003 ²⁾ Volvo Norm ³⁾ Renault Norm ⁴⁾ Volkswagen (56+4 HRC) ⁵⁾ FCA (50+2 HRC) ⁶⁾ Mercedes Benz (49+3 HRC) ⁷⁾ BMW (52-2 HRC)

All dimensions in mm/inch

- | | | |
|-----------|----------------------|-----------|
| IT | Piastra di contrasto | Temperato |
| EN | Counter plate | Hardened |
| DE | Stellplatten | Gehärtet |
| FR | Plaques d'appui | Tempré |
| ES | Placas de soporte | Templado |
| PT | Placas de apoi | Temperado |

CODE	R		B		C		D		ØE		ØF			
	mm	inch	mm	inch	mm	inch	mm	inch	mm	inch	mm	inch		
39PA050A ⁵⁾	25	0.98	21	0.83	15	0.59	10	0.39	9	0.35	15	0.59	d < 15	0.59
39PA070A ⁵⁾	35	1.38	32	1.26	20	0.79	13	0.51	11	0.43	18	0.71	d < 25	0.98
39PA094A ⁵⁾	47	1.85	48	1.89	20	0.79	13	0.51	11	0.43	18	0.71	d < 50	1.97

⁵⁾ Fiat

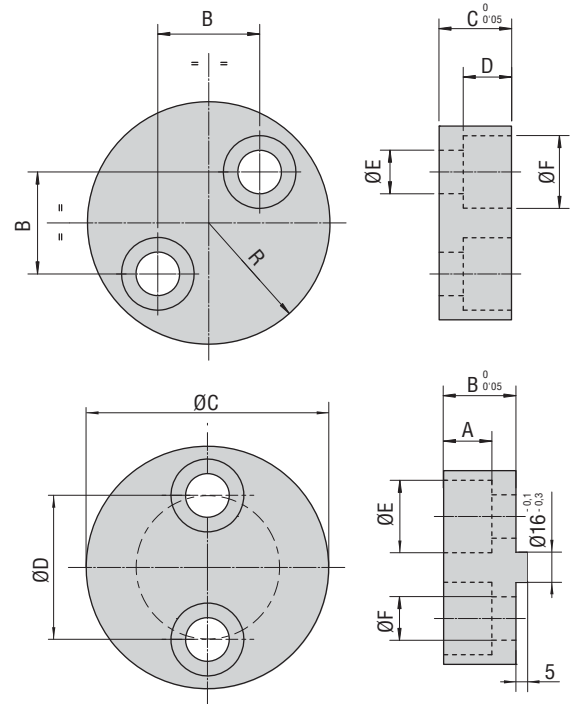

CODE	A		B		ØC		ØD		ØE		ØF			
	mm	inch	mm	inch	mm	inch	mm	inch	mm	inch	mm	inch		
39PA098A ⁴⁾	12	0.47	20	0.79	98	3.86	73	2.87	20	0.79	13,5	0.53	d < 50	1.97
39PA113A ⁴⁾	12	0.47	20	0.79	113	4.45	88	3.46	20	0.79	13,5	0.53	d < 65	2.58
39PA128A ⁴⁾	12	0.47	20	0.79	128	5.04	103	4.06	20	0.79	13,5	0.53	d < 80	3.15
39PA143A ⁴⁾	12	0.47	20	0.79	143	5.63	118	4.65	20	0.79	13,5	0.53	d < 95	3.74

⁴⁾ Volkswagen

- | | | |
|-----------|-------------------------|-----------|
| IT | Calotta | Temperato |
| EN | Thrust plates | Hardened |
| DE | Schaftkappe | Gehärtet |
| FR | Calotte pour tiges | Tempré |
| ES | Casquillo para vástagos | Templado |
| PT | Calote para embolo | Temperado |

49 - 52 HRC

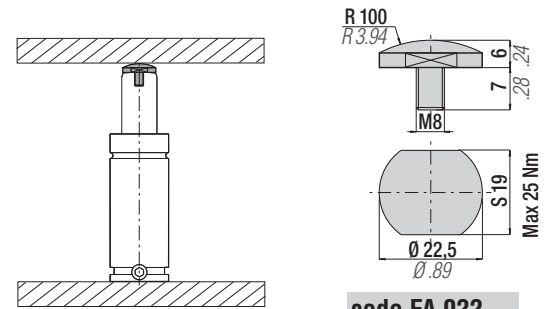

- | | | | |
|-----------|-----------------|--------------------------------|---------------------|
| IT | Pressostato | Tensione di lavoro 48 V max | Normalmente aperto |
| EN | Pressure switch | Operating voltage 48 V max | Normally opened |
| DE | Druckwächter | Arbeitsspannung 48 V max | Normalerweise offen |
| FR | Pressostat | Tension d'utilisation 48 V max | Normalement ouvert |
| ES | Presostato | Tensión de trabajo 48 V max | Normalmente abierto |
| PT | Pressostato | Tensão de Trabalho 48 V max | Normalmente aberto |

PRESSURE SWITCH

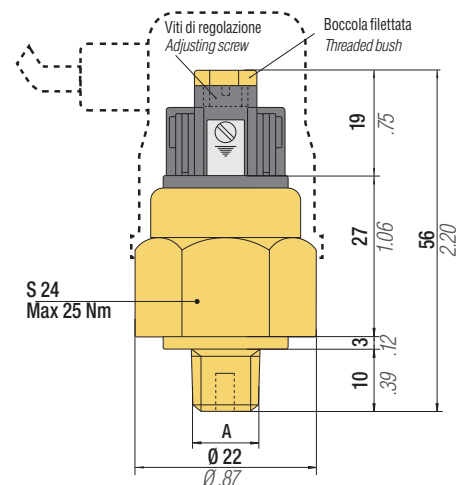
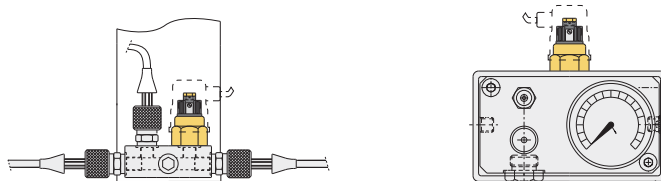

All dimensions in mm/inch

CODE	A	Range
PMM150A	1/8 " BSPT	50:150 bar
PMM300A	1/8 " BSPT	50:300 bar
PMM150A01	1/4 " BSPT	50:150 bar
PMM300A01	1/4 " BSPT	50:300 bar

code 39DMA



- IT** Dispositivo completo per le operazioni di controllo, riduzione/aumento della pressione o caricamento di cilindri autonomi e sistemi collegati.
- EN** Complete device designed and built for checking operations, decreasing/increasing pressure, or charging self-contained cylinders and linked systems.
- DE** Komplette Vorrichtung zur Kontrolle Operationen, Verminderung / Erhöhung des Drucks, oder Ladung die Selbstständigen gasdruckfedern und verbundenen Systemen.
- FR** Dispositif complet pour les opérations de contrôle, réduction/augmentation de la pression ou chargement de cylindres autonomes et systèmes reliés.
- ES** Dispositivo completo para las operaciones de control, reducción/aumento de la presión o carga de cilindros autónomos y sistemas conectados.
- PT** Dispositivo completo para as operações de controle, redução/aumento da pressão ou carregamento dos cilindros autônomos e sistemas conectados.

39DMA includes:

No. 1	39DMCILA	No. 1	39DMCPVA	No. 1	39IR01A	No. 1	ADM01	No. 1	ADM02
No. 1	ADM03	No. 1	ADM04	No. 1	ADM05	No. 1	ADM06	No. 1	ADM08
No. 1	Declaration of CE conformity		No. 1	User manual					

code 39DMCILA



- IT** Manometro 0 ÷ 315 bar - 2 manopole - valvola di riduzione/scarico pressione - adattatore fisso G1/8" - attacco rapido maschio Cejn - Incluso nel set cod. 39DMA.
- EN** 0 ÷ 315 bar gauge - 2 hand knobs - pressure limitation/discharging valve - G1/8" built in adapter - quickfit male Cejn - included in the set with code 39DMA
- DE** Manometer 0 ÷ 315 bar - 2 Drehknöpfe - Entlüftungsventil - fester Adapter G1/8" - Schnellverschlusskupplung Stecker Cejn - im. 39DMA Ausstattung inbegriffen.
- FR** Manomètre 0 ÷ 315 bar - 2 poignées - soupape de réduction/déchargement pression - Adaptateur fixe G1/8" - enclenchement instantané mâle Cejn - joint dans le kit avec code. 39DMA.
- ES** Manómetro 0 ÷ 315 bar - 2 perillas - válvula de reducción/descarga de presión - adaptador fijo G1/8" - enganche rápido macho Cejn incluido en el set con código. 39DMA.
- PT** Manômetro 0 ÷ 315 bar/psi - 2 manoplas - válvula de redução/descarga pressão - adaptador fixo G1/8" - engate rápido macho Cejn - incluído em conjunto código. 39DMA

code 39DMCPVA

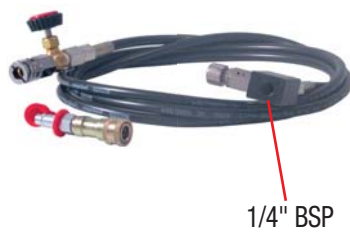

1/4" BSP

- IT** 3 mt di tubo - attacco rapido femmina Cejn - valvola ON/OFF - valvola di scarico tubo - 1 innesto rapido supplementare (SOLO PER CPVB - CPVD) - Incluso nel set cod. 39DMA.
- EN** 3 Mt high pressure hose - quickfit female Cejn - shut-off valve - hose release valve - additional quick coupling (ONLY FOR CPVB - CPVD) - Included in the set with code 39DMA.
- DE** 3 Meter Schlauch - Schnellverschlusskupplung Muffe Cejn - Sperrventil - Rohr Ablassventil - 1 zusätzliche Schnellverschluss Kupplung (NUR FÜR CPVB-CPVD KONTROLLARMATUR) - im. 39DMA Ausstattung inbegriffen.
- FR** 3 m de tuyau - enclenchement instantané femelle Cejn - soupape ON/OFF - soupape de déchargement tuyau - 1 enclenchement instantané supplémentaire (UNIQUEMENT POUR CPVB - CPVD) - joint en le jeu cod. 39DMA.
- ES** 3 mt de tubo - enganche rápido hembra Cejin - válvula ON/OFF - válvula de descarga tubo - 1 inserción rápida suplementaria (SÓLO PARA CPVB - CPVD) - incluido en el set cod. 39DMA.
- PT** 3 mt de tubo - engate rápido fêmea Cejin - válvula ON/OFF - válvula de descarga tubo - 1 engate rápido suplementar (SOMENTE PARA CPVB - CPVD) - incluído em conjunto cod. 39DMA.

code 39IR01A



ISO 72 - C - 2 - 2 - RP

- IT** Innesto rapido femmina per dispositivo 39DMCPVA (USARE SOLO CON PANNELLI CPVB - CPVD).
- EN** Quick female coupling for device 39DMCPVA (SUITABLE ONLY FOR CPVB - CPVD PANELS).
- DE** Schnellverschlusskupplung Muffe für Ausstattung 39DMCPVA (NUR FÜR CPVB - CPVD KONTROLLARMATUR)
- FR** Enclenchement instantané femelle pour dispositif 39DMCPVA (N'UTILISER QU'AVEC PANNEAUX CPVB - CPVD).
- ES** Inserción rápida hembra para dispositivo 39DMCPVA (USO SOLAMENTE CON PANELES CPVB - CPVD).
- PT** Engate rápido fêmea para dispositivo 39DMCPVA (USE UNICAMENTE COM PAINÉIS CPVB - CPVD).

code 39IRFA



Cejn 358

- IT** Innesto rapido femmina per dispositivo 39DMCPV (NON USARE CON PANNELLI CPVB - CPVD).
- EN** Quick female coupling for device 39DMCPV (NOT SUITABLE FOR CPVB - CPVD PANELS).
- DE** Schnellverschlusskupplung Muffe für Ausstattung 39DMCPV (NICHT MIT CPVB - CPVD ARMATUR VERWENDEN)
- FR** Enclenchement instantané femelle pour dispositif 39DMCPV (NE PAS UTILISER AVEC PANNEAUX CPVB - CPVD).
- ES** Inserción rápida hembra para dispositivo 39DMCPV (NO USAR CON PANELES CPVB - CPVD).
- PT** Engate rápido fêmea para dispositivo 39DMCPV (NÃO USE COM PAINÉIS CPVB - CPVD).

code 39QDFV01 for 1/8G thread
code 39QDFV02 for M6 thread
code 39QDFV03 for M6 thread



- IT** Adattatore per caricamento diretto con innesto rapido maschio Cejn.
- EN** Cejin male quick fit adapter for direct charging.
- DE** Adapter für direkt Ladung mit Schnellverschlusskupplung Stecker Cejin
- FR** Adaptateur direct pour le chargement avec enclenchement instantané mâle Cejin.
- ES** Adaptador directo para la carga con enganche rápido macho Cejin.
- PT** Adaptador direto para la carga con engate rápido macho Cejin.

tab below.

Code	39QDFV01	39QDFV03	39QDFV02	39QDFV03	39QDFV02	39QDFV02	39QDFV02	39QDFV03	39QDFV01
Modello Model Modell Model Modelo	ML1800-12000 (rev A)	HR300 Cu 5-16 HR500 Cu 5-16 HR700 Cu 10-16 HRF700 Cu 10-16 ML500 ML1000 LI400 Cu 13	NE16, NE24 (rev A) HR1000-4200 HRF1000 LI900-2000	SC150, SC250 SCF250, H300 H500, HF500 HR500 Cu 25-125 HR700 Cu 19-125 HRF500 Cu 25-125 HRF700 Cu 19-125 LI400 Cu 25-100	K40 ML300	HR200 MCS19 MCS19-TBM MCS19-TBI MCS19-TEM MCS25	NE16 - NE24 (revB) NG16 - NG24 M50 - M70 M90 - MS90 M90 TBM - TBI - TEM M200 - MS200 M300 KE400-7500 RV170-2400 RS170-2400 SC150 - 250 (rev D) H 300 - 500 (rev C) ML300 (rev B+C)	ML500-1000 (rev B+C)	SC500-10000, SCF500-750 H700-18500 HF700-1000 HR6600-11800 LI3200 LS1500-9500 KE12000-18500 S500-S3000 RV4200-RV20000 RS4200-RS9500 RF750-RF2400 RG750-RG6600 RT350-RT9500 ML1800-ML12000 (rev B+C)
A	G1/8"	M6	M6	M6	M6	M6	M6	M6	G 1/8"
Code	ADM01	ADM02	ADM03	ADM04	ADM05	ADM06	ADM08	ADM09	Direttamente con 39DMA (senza adattatore) Directly with 39DMA (without adapter) Direkt mit 39DMA (ohne Adapter) Directement avec 39DMA (sans adaptateur) Directamente con 39DMA (sin adaptador) Directamente com 39DMA (sem adaptador)

code ADM...

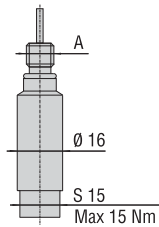

- IT** Adattatore per dispositivo 39DMCILA.
- EN** Adapter for 39DMCILA device.
- DE** Adapter für 39DMCILA Vorrichtung.
- FR** Adaptateur pour dispositif 39DMCILA.
- ES** Adaptador para dispositivo 39DMCILA.
- PT** Adaptador para dispositivo 39DMCILA.

tab above.

ACCESSORIES



IT Dispositivo di scaricamento

DE Ablassvorrichtung

ES Dispositivo de descarga

EN Discharging device

FR Dispositif de déchargement

PT Dispositivo de descarga

code 39DDS-...

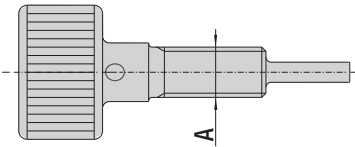

Code	39DDS-M6/1	39DDS-M6/2	39DDS-M6/3	39DDS-1/8G1	39DDS-1/8G
A	M6	M6	M6	G 1/8"	G 1/8"
Model	MCS K ML (rev. A) HR LI	NE (rev. A) SC (rev. B) H (rev. A) HR LI	NE (rev. B) NG M MS KE ML (rev. B + C) RV RS SC (rev. D) H (rev. C)	K ML (rev. A)	SC H HR LI LS KE (rev. B) S RV RS RF RT RG

39DDS01A

39DDS01A

IT Dispositivo di scaricamento

DE Ablassvorrichtung

ES Dispositivo de descarga

EN Discharging device

FR Dispositif de déchargement

PT Dispositivo de descarga

code 39DDS01A

A	M6
Model	NE (rev. B) NG M MS KE ML (rev. B + C) MP MQ RV RS SC (rev. D) H (rev. C)



A	G 1/8"
Model	SC H HR LI LS KE (rev. B) ML (rev. B) S RV RS RF RT RG



THIS PAGE IS INTENTIONALLY LEFT BLANK

code 47T...

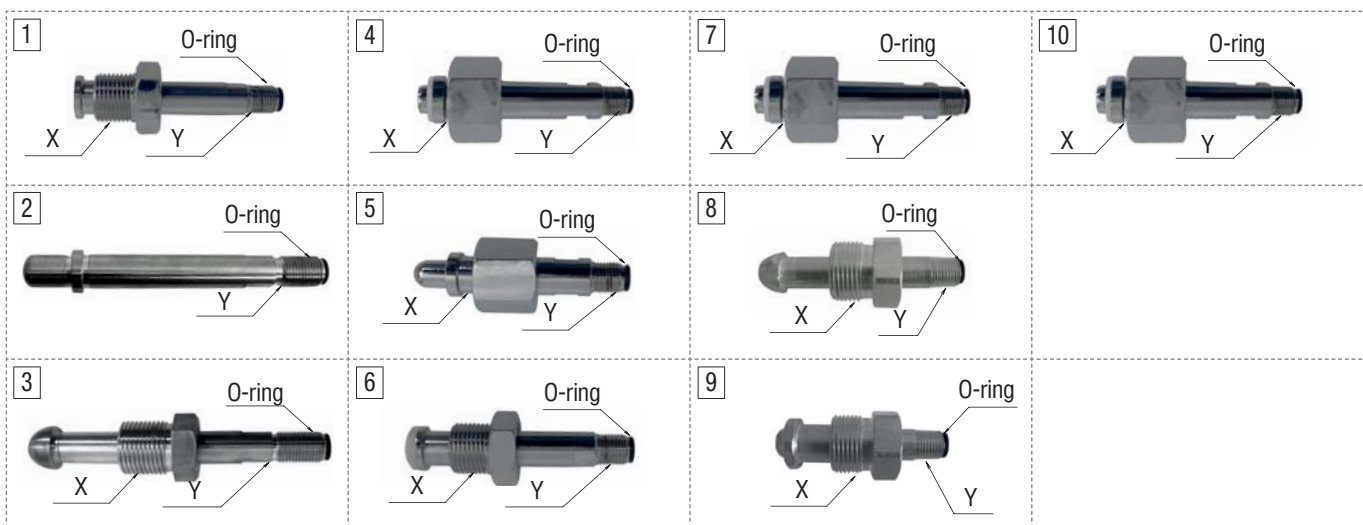

code	IMG	Y	X	COUNTRY
47TB	1	1/4" BSP	W 21,7x1/14" - Male - UNI 4409	Italy
47TB01	2	1/4" BSP	-	China - Korea
47TB02	3	1/4" BSP	14 G 7/16" - Male	Japan - Indonesia
47TB03	4	1/4" BSP	W 24,32x1/14" - Female - DIN 477 - 10 N2	Germany
47TB04	5	1/4" BSP	MFE 29 - 650 CXR133 - Female	France
47TB05	6	1/4" BSP	W 21,7x1/14" - Male	India
47TB06	7	1/4" BSP	G 3/4"	Russia
47TB07	8	1/4" BSP	W 24,5x1/14" - Male ($\leq 206 \text{ bar} / 3000 \text{ psi}$)	USA
47TB08	9	1/4" BSP	W 26,41x1/14" - Male ($> 206 \text{ bar} / 3000 \text{ psi}$)	USA
47TB09	10	1/4" BSP	M 21,7x1-814 - Female	Spain

Example:
47TB

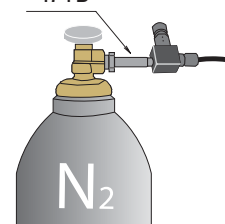

IT Tubo per collegamento tra riduttore e bombola gas Azoto

FR Tuyau pour le lien entre le réducteur et la bouteille de gaz Azote

EN Connecting hose between pressure regulator and nitrogen tank

ES Tubo para conexión entre reductor y bombona gas Nitrógeno

DE Verbindungsrohr zwischen Druckminderer und Stickstoff-Gasflasche

PT Tubo para ligação entre redutor e garrafa de gás Azoto

code 39R....

code	Riduttore di pressione + attacco Pressure reducer + connection Druckminderer + Verbindung Réducteur de pression + jonction Reductor de presión + enganche Redutor de pressão + engate	COUNTRY
39RP	39R + 47TB	Italy
39RP01	39R + 47TB01	China - Korea
39RP02	39R + 47TB02	Japan - Indonesia
39RP03	39R + 47TB03	Germany
39RP04	39R + 47TB04	France
39RP05	39R + 47TB05	India
39RP06	39R + 47TB06	Russia
39RP07	39R + 47TB07	USA
39RP09	39R + 47TB09	Spain

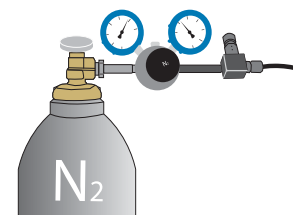

IT Riduttore di pressione completo di attacco bombola per controllare e ridurre la pressione.

FR Réducteur de pression complet avec jonction de bouteille pour contrôler et réduire la pression.

EN Pressure reducer complete with cylinder connection to control and reduce the pressure.

ES Reductor de presión completo con enganche de las bombonas para controlar y reducir la presión.

DE Druckminderer vollständig mit Flasche verbindungs, um die Druck zu überwachen und verringern

PT Redutor de pressão completo com engate para controlar e reduzir a pressão.



code	Tools set	Accessories set
CMC	✓	✓

- IT** Set completo per manutenzione cilindri
- EN** Complete maintenance kit for cylinders
- DE** Komplettes Wartungsset für Gasdruckfedern
- FR** Kit d'entretien complet pour ressorts à gaz
- ES** Kit de mantenimiento completo para resortes de gas
- PT** Kit de manutenção completo para cilindros



code	Tools set	Accessories set
CMCT	✓	✗

- IT** Solo set utensili per manutenzione cilindri
- EN** Tool set only for cylinders' maintenance
- DE** Nur Werkzeugsset zur Wartung von Gasdruckfedern
- FR** Set d'outils pour l'entretien de ressorts à gaz
- ES** Set de herramientas para mantenimiento de resortes de gas
- PT** Conjunto de ferramentas pela manutenção dos cilindros



code	Tools set	Accessories set (specific family of cylinders)
CMC - ...	✗	✓

- IT** Set accessori per determinata famiglia di cilindri (es. CMC-SC 10000)
- EN** Set of accessories for a specific family of cylinders (ex. CMC-SC 10000)
- DE** Zubehörset für bestimmte Zylindertypen (z. B. CMC-SC 10000)
- FR** Jeu d'accessoires pour une famille donnée de cylindres (ex.: CMC-SC 10000)
- ES** Set de accesorios para una determinada familia de cilindros (p.ej. CMC-SC 10000)
- PT** Acessórios de conjunto para determinada família de cilindros (ex. CMC-SC 10000)

- IT** Chiave dinamometrica con accessori
- EN** Chiave dinamometrica con accessori
- DE** Chiave dinamometrica con accessori
- FR** Chiave dinamometrica con accessori
- ES** Chiave dinamometrica con accessori
- PT** Chiave dinamometrica con accessori



Torque force

code	Nm
58UT025A	4 - 40



code
58UT013A



code	size	
	mm	inch
58UT009A	3	0.12
58UT010A	4	0.16
58UT011A	6	0.24
58UT012A	8	0.31



code	size	
	mm	inch
58UT014A	10	0.39
58UT015A	12	0.47
58UT016A	14	0.55
58UT017A	15	0.59
58UT018A	17	0.67
58UT019A	18	0.71
58UT020A	19	0.75

ORDERING EXAMPLE

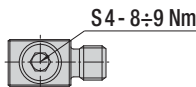
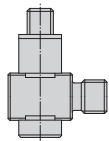

58UT025A
+
58UT013A
+
58UT010A

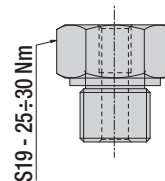

58UT025A
+
58UT020A

WARNING PLATE

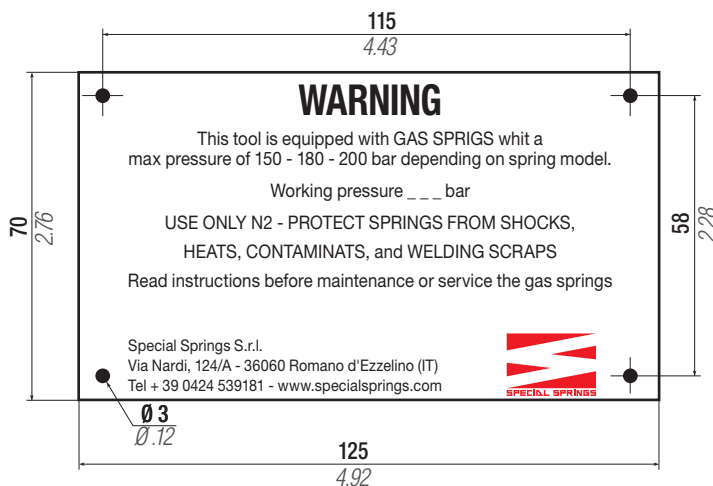

- IT** Targhetta
- EN** Advice plate
- DE** Schilder
- FR** Plaquettes
- ES** Placas
- PT** Etiquetas

Codice	39 TAR-I
Code	39 TAR-GB
Bestell-nummer	39 TAR-D
Référence	39 TAR-F
Codigo	39 TAR-E
Codigo	39 TAR-P

code 58CD01



- IT** Cacciavite dinamometrico per valvola unidirezionale
- EN** Torque screwdriver for one-way valve
- DE** Drehmomentschrauber für Rückschlagventil
- FR** Tournevis dynamométrique pour valve anti-retour
- ES** Destornillador dinámico para válvula anti-retorno
- PT** Chave torquimétrica para válvula de retenção

code 59VU02



- IT** Valvola unidirezionale (esclusi M50, M70, M90-TBM/TEM/TBI, MS90, M200, MS200)
- EN** One-way valve (excluding M50, M70, M90-TBM/TEM/TBI, MS90, M200, MS200)
- DE** Rückschlagventil (außer M50, M70, M90-TBM/TEM/TBI, MS90, M200, MS200)
- FR** Valve anti-retour (à l'exclusion de M50, M70, M90-TBM/TEM/TBI, MS90, M200, MS200)
- ES** Válvula anti-retorno (excepto M50, M70, M90-TBM/TEM/TBI, MS90, M200, MS200)
- PT** Válvula de retenção (excluindo M50, M70, M90-TBM/TEM/TBI, MS90, M200, MS200)

code 39PM02A



- IT** Pressa manuale per assemblaggio stelo, boccia e anello di ritegno a C
- EN** Table manual press for assembly of piston-rod, assembled bushing and retaining C-ring
- DE** Manuelle Presse zur Montage von Kolbenstange, Buchse und Sprengring
- FR** Presse manuelle pour l'assemblage de la queue, douille et bague d'étanchéité en C
- ES** Prensa manual para ensamblaje perno, casquillo y anillo de retención a C
- PT** Prensa manual para ensambladura haste, bucha e aro de retenção a C

code 39RFG



- IT** Spray rivelatore di fughe
- EN** Gas detector
- DE** Gasdetektor Spray
- FR** Spray détecteur de fuites de gaz
- ES** Spray detector de escapes de gas
- PT** Spray revelador de fugas de gás

ACCESSORIES

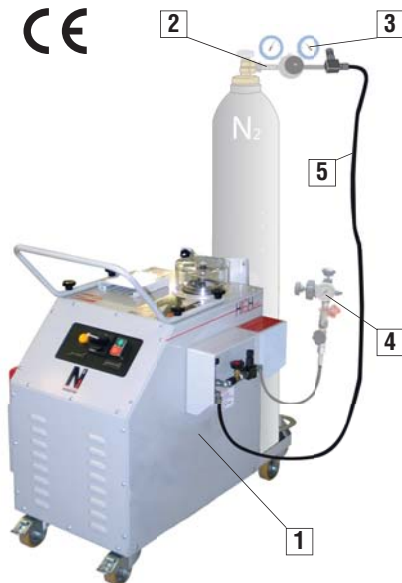

Booster carrellato per il caricamento di grandi volumi di azoto, con azionamento elettro-idraulico per la massima velocità.
 Wheeled Booster for the filling of large volumes of nitrogen, with electro-hydraulic start-up for the maximum speed.
 Ein fahrbares Booster, für die Ladung aus großen Mengen von Stickstoff, mit elektrohydraulischer Antrieb für die Maximaldrehzahl.
 Booster à chariot, pour la charge de grands volumes d'azote, avec actionnement électro-hydraulique pour la vitesse maximum.
 Booster sobre ruedas para la carga de grandes volúmenes de nitrógeno con accionamiento electro-hidráulico para la velocidad máxima.
 Booster rodado para o carregamento de grandes volumes de nitrogênio com acionamento eletro-hidráulico para a velocidade máxima.

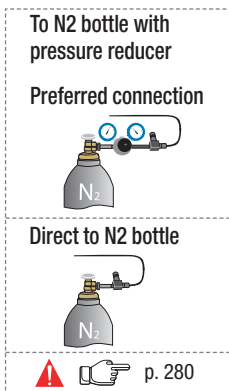

CODE	Booster + Connection p. 280 1 + 2	COUNTRY
39NCU01A	Booster unit + 47TB	Italy
39NCU10A	+ 47TB01	China - Korea
39NCU11A	+ 47TB02	Japan - Indonesia
39NCU12A	+ 47TB03	Germany
39NCU13A	+ 47TB04	France
39NCU14A	+ 47TB05	India
39NCU15A	+ 47TB06	Russia
39NCU22A	+ 47TB07	USA
39NCU23A	+ 47TB08	USA
39NCU29A	+ 47TB09	Spain

- | | | | | |
|---|--|---|---|--|
| <p>1 -
Unità booster
Booster unit
Booster Gerät
Unité Booster
Unidad Booster
Unidade Booster</p> | <p>2 -
Attacco per bombola (v. pg. 280)
Connection for bottle (see p. 280)
Ansatz für die Flasche (siehe s. 280)
Décapage pour bombonne (voir p. 280)
Ataque a la Bombona (ver pág. 280)
Ataque a Bottle (ver p. 280)</p> | <p>3 -
Riduttore di pressione - non incluso
Pressure reducer - not included
Druckminderer - nicht inbegriffen
Réducteur de pression - non inclus
Reductor de presión - no incluido
Redutor de pressão - não incluído</p> | <p>4 -
Dispositivo di caricamento DMA - non incluso (v. pg. 276)
Charging device DMA - not included (see p. 276)
Ladung Vorrichtung DMA - nicht inbegriffen (siehe s. 276)
Dispositif de charge DMA - non inclus (voir p. 276)
Dispositivo de carga DMA - no incluido (ver pág. 276)
Dispositivo de carregamento de DMA - não incluído (ver p 276)</p> | <p>5 -
Tubo collegamento bombola con valvola di scarico
Connecting hose from the bottle to the valve discharging
Verbindung Schlauche des Flasche mit Auslassventil
Tube pour la connexion bombonne avec valve de décharge
Tubo de conexión de la Bombona con la válvula de descarga
Tubo de ligação Frasco com a válvula de descarga</p> |
|---|--|---|---|--|

IT

Caratteristiche - vantaggi

- Massima sicurezza, minimi tempi di caricamento
- Arresto automatico alla pressione impostata
- Segnale luminoso di fine ciclo
- Valvola di sicurezza per sovrappressione
- Pompa elettrica
- Pressione di uscita regolabile
- Telaio carrellato con alloggiamento bombola N2
- Utilizzare con set di caricamento DMA (opzionale)

La fornitura comprende

- Unità booster
- 3 mt di tubo per collegamento a bombola o riduttore di pressione + attacco per bombola

FR

Caractéristiques - avantages

- sécurité maximum, temps de chargement minimum
- arrêt automatique à la pression établie
- signal lumineux de fin de cycle
- valve de sécurité pour la surpression
- pompe électrique
- Pression de sortie réglable
- Châssis à chariot avec logement de bonbonne N2
- À utiliser avec le set de chargement DMA (en option)

La fourniture inclut

- Unité booster
- 3 mt de tube pour la connexion à la bombonne ou au réducteur de pression + Décapage bombonne

EN

Features - advantages

- maximum safety, low charging time
- automatic stop when the set pressure is reached
- Light indicator of cycle end
- Safety valve for overpressure
- Electric pump
- Adjustable output pressure
- Wheeled cart with N2 bottle housing
- To be used with charging set DMA (optional)

The supply includes

- Booster unit
- 3 mt hose for connecting the bottle or pressure reducer + bottle connection

ES

Características - Ventajas

- Máxima seguridad, tiempo mínimo de carga.
- Parada automática en la presión elegida
- Señal luminosa de final de ciclo
- Válvula de seguridad para sobrepresión
- Bomba eléctrica
- Presión de salida regulable
- Chasis sobre ruedas y alojamiento para botella de N2
- Utilizar combinado con set de carga DMA (opcional)

El suministro incluye

- Unidad Booster
- Tubo de 3 mt para conexión a la bombona o al reductor de presión + Ataque Bombona

DE

Eigenheiten - Vorteile

- Maximale Sicherheit, minimale Befüllzeiten
- Automatisches Anhalten beim Erreichen des Drucks
- Leuchtsignal bei Zyklusende
- Überdruck-Sicherheitsventil
- Elektrische Pumpe
- Einstellbarer Output-Druck
- Fahrbares Gestell mit Ablagefach für N2-Gasflasche
- Zum Einsatz mit der DMA Ladevorrichtung (optional)

Die Lieferung beinhaltet

- Booster Gerät
- 3 Meters Schlauch für den Anschluss zur Flasche oder zum Druckminderer + Ansatz für die Flasche

PT

Características - Benefícios

- Máxima segurança, tempos de carregamento mais baixos
- Paragem automática quando atingida a pressão especificada
- Sinal luminoso de fim de ciclo
- Válvula de segurança activa sobrepresão
- Bomba eléctrica
- Saída de pressão ajustável
- Quadro rodado com alojamento para tank N2
- Utilizado com o conjunto de carregamento DMA (opcional)

O fornecimento inclui

- Unidade Booster
- 3 mt tubo para ligação ao cilindro de azoto ou de reductor de pressão + Ataque a Bottle

	Pmax	Pmin	Vm	°F °C	H x P x H L x P x H	Kg
 230/400/415/440/ 480/575 V - 50 Hz / 60Hz	210 bar 3045 psi	30 bar 435 psi	1300 NL / min *	0 - 45 °C 32 - 113 °F	600 x 560 x 680 mm 24 x 22 x 27 inch	138 Kg 304 lbs

* Il rendimento volumetrico varia in funzione di PN₂ - The volumetric efficiency varies according to PN₂ - Der Liefergrad ändert sich in Abhängigkeit vom PN₂
 Le rendement volumétrique varie en fonction de PN₂ - El rendimiento volumétrico varia en función de Pair et PN₂ - O rendimento volumétrico varia em função da PN₂

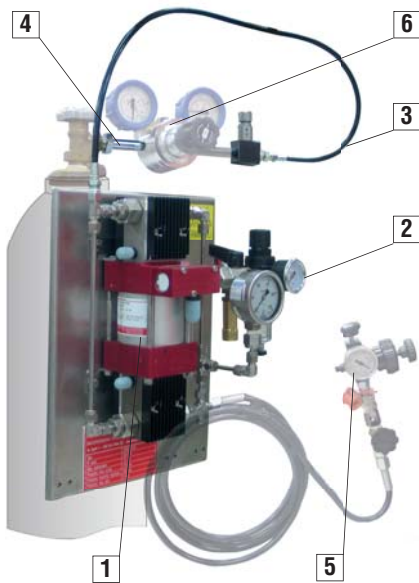

To N2 bottle with pressure reducer

Preferred connection



Direct to N2 bottle



p. 280

Booster portatile compatto per caricamento azoto con azionamento pneumatico
 Compact portable booster for the filling of nitrogen, with pneumatic start-up
 Ein kompakter und Portabler Booster für die Ladung von Stickstoff, mit pneumatischer Betätigung
 Booster compacte et portable pour la charge avec azote, avec actionnement pneumatique
 Booster compacto y portátil para la carga con nitrógeno con accionamiento neumático
 Booster compacto e portátil para carregar com nitrogênio com acionamento pneumático

CODE	Booster + Connection p. 280 1 + 4	COUNTRY
39NCU03A	Booster unit + 47TB	Italy
39NCU04A	+ 47TB01	China - Korea
39NCU05A	+ 47TB02	Japan - Indonesia
39NCU06A	+ 47TB03	Germany
39NCU07A	+ 47TB04	France
39NCU08A	+ 47TB05	India
39NCU09A	+ 47TB06	Russia
39NCU26A	+ 47TB07	USA
39NCU27A	+ 47TB08	USA
39NCU28A	+ 47TB09	Spain

- 1 - Unità booster
Booster unit
Booster Gerät
Unité Booster
Unidad Booster
Unidade Booster
- 2 - Valvola sicurezza e ingresso aria
Safety valve and air inlet
Sicherheit Ventile und Luft Eingang
Valve de sécurité et entrée de l'air
Válvula de Seguridad y ingreso aire
Válvula de segurança e entrada de ar
- 3 - Tubo collegamento bombola con valvola di scarico
Connecting hose from the bottle to the valve discharging
Verbindung Schlauche des Flasche mit Auslassventil
Tube pour la connexion bombonne avec valve de décharge
Tubo de conexión de la Bombona con la válvula de descarga
Tubo de ligação Frasco com a válvula de descarga
- 4 - Attacco per bombola (v. pg. 280)
Connection for bottle (see p. 280)
Ansatz für die Flasche (siehe s. 280)
Décapage pour bombonne (voir p. 280)
Ataque a la Bombona (ver pág. 280)
Ataque a Bottle (ver p. 280)
- 5 - Dispositivo di caricamento DMA - non incluso (v. pg. 276)
Charging device DMA - not included (see p. 276)
Ladung Vorrichtung DMA - nicht inbegriffen (siehe s. 276)
Dispositif de charge DMA - non inclus (voir p. 276)
Dispositivo de carga DMA - no incluido (ver pág. 276)
Dispositivo de carregamento de DMA - não incluído (ver p 276)
- 6 - Riduttore di pressione - non incluso
Pressure reducer - not included
Druckminderer - nicht inbegriffen
Réducteur de pression - non inclus
Reductor de presión - no incluido
Redutor de pressão - não incluído

IT

Caratteristiche - Vantaggi

- Compatto, leggero e portatile
- Massimo utilizzo del volume bombola N2
- Installazione diretta su bombola N2
- Valvola di sicurezza output N2 max 220 bar

La fornitura comprende

- Unità booster completa di valvola di sicurezza
- Supporto per bombola
- 1 mt di tubo per collegamento a bombola o riduttore di pressione + attacco per bombola

FR

Caractéristiques - Avantages

- Compacte, léger et portable
- Utilisation maximale de la bombonne d'azote N2
- Installation directe sur la bombonne d'azote N2
- Valve de sortie N2 sécurisé max 220 bar

La fourniture inclut

- Unité booster équipé avec valve de sécurité
- Support pour bombonne
- 1 mt de tube pour la connexion à la bombonne ou au réducteur de pression + Décapage bombonne

EN

Features - Advantages

- Compact, light and portable
- Max use of the nitrogen bottle N2
- Direct installation on the N2 bottle
- Safety N2 output valve max 220 bar

The supply includes

- Booster unit provided with safety valve
- Bottle support
- 1 mt hose for connecting the bottle or pressure reducer + bottle connection

ES

Características - Ventajas

- Compacto, ligero y portátil
- Uso máximo de la bombona de nitrógeno N2
- Instalación directamente sobre la bombona de N2
- Válvula de seguridad, output N2 max 220 bar

El suministro incluye

- Unidad Booster equipado con válvula de seguridad
- Soporte para la bombona de nitrógeno
- Tubo de 1 mt para la conexión a la bombona o al reductor de presión + Ataque Bombona

DE

Eigenschaften - Vorteilen

- Kompakt, licht und portabel.
- Maximaler Nutzung der Stickstoffflasche N2.
- Direkter Installation am Stickstoffflasche N2.
- Sicherheit Ventile von N2 Ausgabe, max. 220 bar

Die Lieferung beinhaltet

- Booster Gerät versehen mit Sicherheit Ventile.
- Träger für die Stickstoffflasche.
- 1 Meters Schlauch für den Anschluss zur Flasche oder zum Druckminderer + Ansatz für die Flasche

PT

Características - Benefícios

- Compacto, leve e portátil
- Máxima utilização do cilindro de nitrogênio N2
- Instalação diretamente sobre o cilindro de N2
- Válvula de segurança, saída máxima de 220 bar N2

O fornecimento inclui

- Unidade Booster equipado com válvula de segurança
- O suporte para o cilindro de nitrogênio
- 1 mt tubo para ligação ao cilindro de azoto ou de redutor de pressão + Ataque a Bottle

	Pmax	Pmin	Vm			
AIR 1 - 10 bar 15 - 145 psi	220 bar 3190 psi	30 bar 435 psi	280 NL / min *	0 - 45 °C 32 - 113 °F	230 x 350 x 230 mm 9 x 13 x 9 inch	10,8 Kg 23,8 lbs

* Il rendimento volumetrico varia in funzione di Pair e PN2 - The volumetric efficiency varies according to Pair and PN2 - Der Liefergrad ändert sich in Abhängigkeit vom Pair und PN2
 Le rendement volumétrique varie en fonction de Pair et PN2 - El rendimiento volumétrico varia en función de Pair et PN2 - O rendimento volumétrico varia em função da Pair e PN2

ACCESSORIES - DIGITAL FORCE TESTER



code FT2000

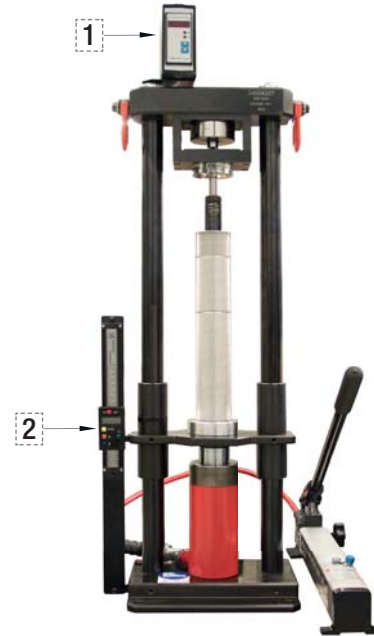

code FT250

code FT500

<p>Measuring range</p>	<p>0 ÷ 2000 daN 0 ÷ 4496 lb</p>	<p>0 ÷ 250 daN 0 ÷ 562 lb</p>	<p>0 ÷ 500 daN 0 ÷ 1124 lb</p>
<p>Recommended for FO</p>	<p>0 ÷ 1500 daN 0 ÷ 3372 lb</p>	<p>0 ÷ 250 daN 0 ÷ 562 lb</p>	<p>250 ÷ 500 daN 562 ÷ 1124 lb</p>
<p>Accuracy according EN ISO 7500-1</p>	<p>-</p>	<p>CLASS 1 (± 1%)</p>	<p>CLASS 1 (± 1%)</p>
	<p>22 Kg 48.50 lb</p>	<p>82 Kg 180.78 lb</p>	<p>82 Kg 180.78 lb</p>

code 59VCATM02



DIGITAL DISPLAY

code 59RE150



DIGITAL LINEAR SCALE



code FT7500



code IPC/DIG

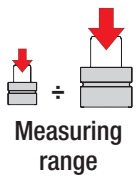

0 ÷ 7500 daN
0 ÷ 16861 lb

0 ÷ 20000 daN
0 ÷ 44962 lb



500 ÷ 7500 daN
1124 ÷ 16861 lb

7500 ÷ 20000 daN
16861 ÷ 44962 lb



CLASS 1
(± 1%)

CLASS 1
(± 1%)



82 Kg
180.78 lb

210 Kg
462.97 lb

code 59VCATM02



DIGITAL DISPLAY

code 59RE150



DIGITAL LINEAR SCALE

code 59VCM051



DIGITAL DISPLAY

NITROGEN PUNCHING UNIT

Initial force up to 2000 daN
Stripping force up to 4000 daN

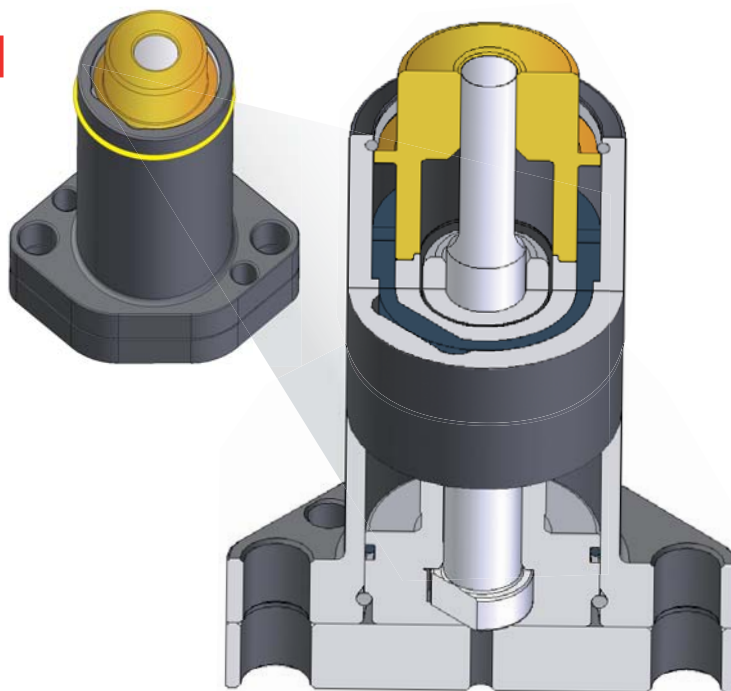
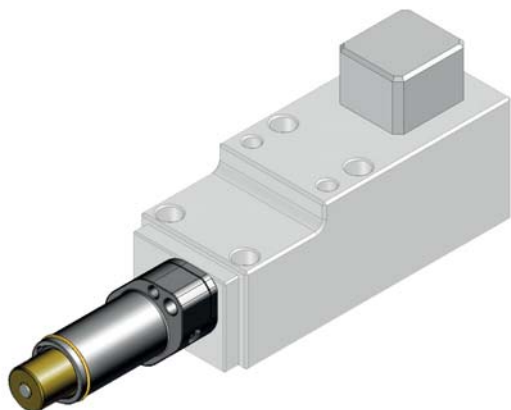

IT Richiedere o scaricare dal sito www.specialsprings.com il catalogo.

EN Ask for or download the catalogue from our web site www.specialsprings.com.

DE Den Katalog anfordern oder von unserer Internetseite www.specialsprings.com herunterladen.

FR Demandez ou téléchargez notre catalogue à partir de notre site web www.specialsprings.com.

ES Solicitar o descargar de la web www.specialsprings.com el catálogo.

PT Requerer ou descarregar no site www.specialsprings.com o catálogo.

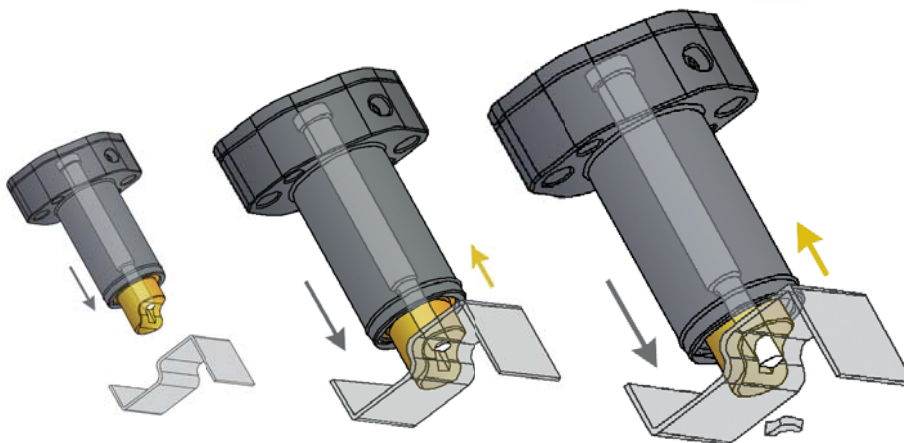

IT - Testa prelamiera estraibile e sagomabile
- Facile posizionamento e fissaggio
- Elevata forza di estrazione
- Dimensioni compatte
- Adatto per punzoni ISO 8020
- Non è richiesto l'uso di altro portapunzone
- Ideale per uso combinato con unità cam

FR - Tête de bronze que peut être modelée et extraite
- Positionnement facile
- Force élevée de extraction
- Dimensions compactes
- Indiqué pour poinçons ISO 8020
- Il ne demande pas l'emploi de autre poinçon
- Idéal à utiliser avec l'unitée CAM

EN - Stripper head removable and mouldable
- Easy positioning
- High and adjustable holding and stripping force
- Compact dimensions
- Suitable for ISO 8020 shoulder style punch
- Doesn't require the use of standard retainer
- Ideal for combined use with cam unit

ES - Cabeza de despegador desmontable y moldeable
- Fácil posicionamiento
- Fuerza de extracción superior y ajustable
- Dimensiones compactas
- Apropiado para punzón con cabeza ISO 8020
- No requiere uso de porta punzón estándar
- Ideal para utilizar con carro

DE - Niederhalterkopf herausnehmbar und mit bearbeitbarer Kontur
- Einfache Positionierung
- Hohe und einstellbare Niederhalter- und Abstreiferkraft
- Kompakte Größe
- Geeignet für Schneidstempel ISO 8020
- Andere Stempelhalteplatten sind nicht erforderlich
- Ideal für den Einsatz in Kombination mit Schiebern

PT - Cabeça de corte fácil remoção e maquinável
- Fácil posicionamento
- Fixação alta e ajustável e força de corte
- Dimensões compactas
- Adequado para punção o ISO 8020 respigado
- Não necessita do uso de um retentor normalizado
- Ideal para uso combinado com uma unidade CAM

IT Carichi forti - estrattore a gas con forza di estrazione regolabile. Montaggio diretto su portapunzoni standard per punzoni ball-lock o con testa ISO 8020.

EN Heavy duty - Nitrogen gas stripper with adjustable force. Direct mounting on standard retainers for Ball-Lock or ISO 8020 punches.

DE Schwere Belastung - Gasdruck-Abstreifer mit einstellbarer Kraft. Direktmontage auf Standard-Stempelhalteplatten für Stempel mit Ball-Lock-System oder nach ISO 8020.

FR Charge lourde - Unité de dévêtissage à gaz avec force réglable. Montage direct sur les plaques porte-poinçon standard pour poinçons avec système Ball-Lock ou selon ISO 8020.

ES Carga pesada - Extractor de punzones de nitrógeno con fuerza ajustable. Montaje directo en porta punzones estándares para punzones Ball-Lock o según ISO 8020.

PT Carga pesada - Perfuradores de nitrogênio com força ajustável. Montagem directa em porta punções padrão para punções Ball-Lock ou segundo ISO 8020.

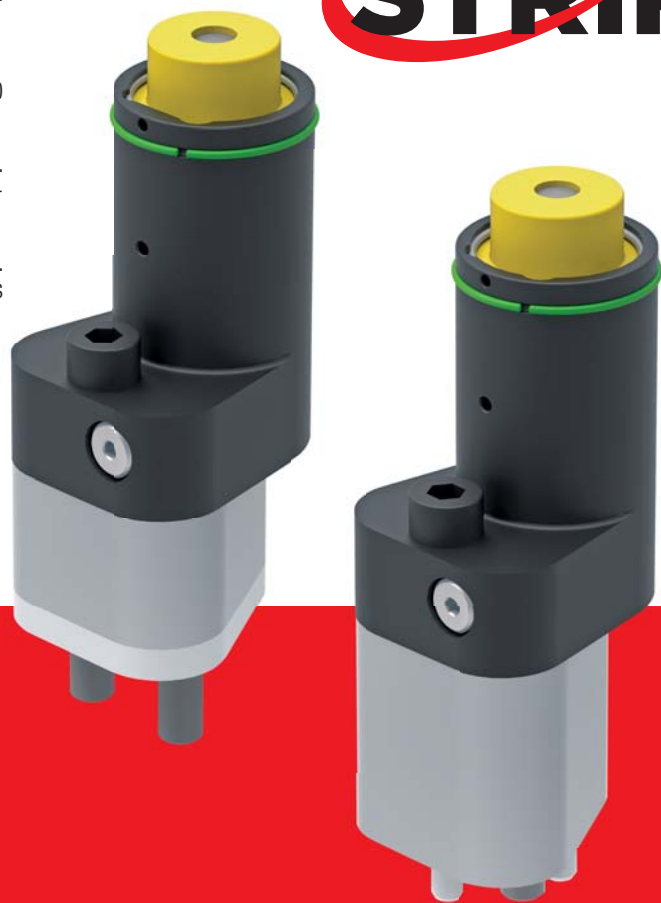

new



OPAS
(Over Pressure Active Safety)

IT Caratteristiche

- Montaggio diretto su portapunzoni standard
- Testina estrattore e premilamiera lunga o corta in bronzo guidata, rimovibile e sagomabile
- Testina anti-rotazione con 8 mm di corsa
- 4 codici colore standard indicativi del carico/forza
- 8 modelli per punzoni da 10 a 40 mm di diametro
- Forza a contatto fino a 1880 daN / 4200 lbf
- Forza di estrazione fino a 3200 daN / 7200 lbf
- Forze di estrazione regolabili
- Collegabile con altre unità NITRO STRIP per massima flessibilità
- Sicurezza OPAS inclusa come standard
- Dimensioni compatte

EN Features

- Direct mounting on standard retainers
- Bronze stripping head that is guided, demountable and machinable. Available short or long
- Anti-rotation head with 8 mm stroke
- 4 standard color codes for different forces/loads
- 8 models with punch diameter from 10 to 40 mm
- Contact force as high as 1880 daN / 4200 lbf
- Stripping force as high as 3200 daN / 7200 lbf
- Adjustable stripping force
- Connectable with other NITRO STRIP units for maximum flexibility
- OPAS built-in as standard
- Compact design

DE Merkmale

- Direktmontage auf Standard-Stempelhalteplatten
- Abstreiferkopf aus Bronze, geführten, abnehm- und bearbeitbar. Verfügbar kurz oder lang
- Abstreiferkopf verdrehgesichert, mit einem Hub von 8 mm
- 4 Standard-Farbcodes für verschiedene Kräfte/ Belastungen
- 8 Modelle mit Stempeldurchmesser von 10 bis 40 mm
- Kontaktkraft bis zu 1880 daN / 4200 lbf
- Abstreiferkraft bis zu 3200 daN / 7200 lbf
- Abstreiferkraft einstellbar
- Anschließbar mit anderen NITRO STRIP Einheiten für maximale Flexibilität
- OPAS standardmäßig eingebaut
- Kompaktes Design

FR Caractéristiques

- Montage direct sur les plaques porte-poinçon standard
- Tête de dévêtisseur de bronze, guidée, démontable et qui peut être usinée. Disponible courte ou longue
- Tête de dévêtisseur résistant à la torsion, avec une course de 8 mm
- 4 codes couleur standard avec différentes forces/charges
- 8 modèles avec diamètres de poinçon de 10 à 40 mm
- Force de contact jusqu'à 1880 daN / 4200 lbf
- Force de dévêtisseur jusqu'à 3200 daN / 7200 lbf
- Force de dévêtisseur ajustable
- Possibilité de relier avec autres unités NITRO STRIP pour une flexibilité maximale
- OPAS installée de série - Design compact

ES Características

- Montaje directo en porta punzones estándares
- Cabeza del extractor de bronce, guiada, desmontable y mecanizable. Disponible corta o larga
- Cabeza anti-rotación con carrera de 8 mm
- 4 códigos de colores estándares para fuerzas/ cargas diferentes
- 8 modelos con diámetro del punzón de 10 a 40 mm
- Fuerza de contacto hasta 1880 daN / 4200 lbf
- Fuerza de extracción hasta 3200 daN / 7200 lbf
- Fuerza de extracción ajustable
- Conectable a otras unidades NITRO STRIP para una máxima flexibilidad
- OPAS incluida como estándar
- Diseño compacto

PT Características

- Montagem directa em porta punções padrão
- Cabeça do destacadador em bronze, guiada, removível e de fácil usinagem. Disponível curta ou longa
- Cabeça anti-rotação com curso de 8 mm
- 4 códigos de cores padrão para diferentes forças/cargas
- 8 modelos com diâmetro da punção de 10 a 40 mm
- Força de contato até 1880 daN / 4200 lbf
- Força de extração até 3200 daN / 7200 lbf
- Força de extração pode ser ajustada
- Possibilidade de interligação com outras unidades NITRO STRIP para o máximo de flexibilidade
- OPAS como padrão
- Design compacto



IT Cos'è DYBO?

È un sistema per controllare e ripristinare automaticamente la pressione nei cilindri ad azoto collegati, senza intervento dell'operatore.

EN What's DYBO?

It is a system to monitor and re-set automatically the pressure of nitrogen linked cylinders without user's intervention.

DE Was ist DYBO?

DYBO ist ein Gerät, um den Druck der Gasdruckfedern in Verbundsystemen zu überwachen und zu steuern, ohne Eingriff des Anwenders.

FR Qu'est-ce que c'est DYBO ?

C'est un système pour contrôler et réinitialiser automatiquement la pression dans les ressort à gaz reliés, sans intervention de l'opérateur.

ES ¿Qué es DYBO?

Es un sistema para controlar y restablecer automáticamente la presión en los cilindros de nitrógeno conectados, sin la intervención del usuario.

PT O que é DYBO?

Trata-se de um sistema para controlar e reinicializar automaticamente a pressão nos cilindros de nitrogénio interligados, sem a intervenção do operador.



new

IT Vantaggi DYBO

- Riduzione dei tempi di fermo produzione
- Riduzione dei costi di stampaggio
- Riduzione degli scarti
- Ripristino automatico dei parametri di pressione
- Registrazione dei parametri della pressione di stampaggio nei cilindri ad azoto
- Gestione simultanea multi zona della pressione
- Collegabile a tutti i pannelli di controllo sul mercato
- Adattabile a tutti gli impianti già in uso senza retrofit

FR Avantages DYBO

- Réduction des arrêts de production
- Réduction du coût des pièces embouties
- Réduction des pièces rejetées
- Réinitialisation automatique des paramètres de pression
- Enregistrement des paramètres de la pression d'emboutissage
- Gestion simultanée et multi-zone de la pression
- Possibilité de raccordement avec tous les panneaux de contrôle sur le marché
- Compatible avec tous les systèmes existants sans réaménagement

EN DYBO benefits

- Reduced production downtime
- Reduced cost of stamped parts
- Reduced rejected parts
- Automatic re-set of pressure settings
- Recording of pressure stamping parameters
- Multi zone simultaneous management of pressure
- Linkable to all nitrogen control panels on the market
- Suitable for all existing systems without retrofitting

ES Ventajas DYBO

- Reducción de las paradas de producción
- Costo reducido de las piezas estampadas
- Reducción de las piezas rechazadas
- Reinicio automático de los parámetros de presión
- Registro de los parámetros de la presión de estampación
- Gestión simultánea y multi-zona de la presión
- Conectable a todos los paneles de control en el mercado
- Apto para todos los sistemas existentes sin retroadaptación

DE Vorteile von DYBO

- Verringert die Ausfallzeiten in der Produktion
- Verringert die Kosten der Pressteile
- Verringert den Produktionsabfall
- Automatische Nachstellung des Solldrucks
- Speicherung der Druckparameter während der Produktion
- Gleichzeitige Steuerung des Drucks in mehreren Kreisläufen
- Anschlussfähig an alle auf dem Markt verfügbare Stickstoffgas-Kontrollarmaturen
- Geeignet für alle bestehenden Systeme ohne Änderungsaufwand

PT Vantagens DYBO

- Redução das interrupções de produção
- Custo reduzido das peças estampadas
- Redução das peças rejeitadas
- Reinicialização automática dos parâmetros de pressão
- Gravação dos parâmetros da pressão de estampagem
- Gestão simultânea e multi-zona da pressão
- Conectável a todos os painéis de controle no mercado
- Adequado para todos os sistemas existentes sem readaptação

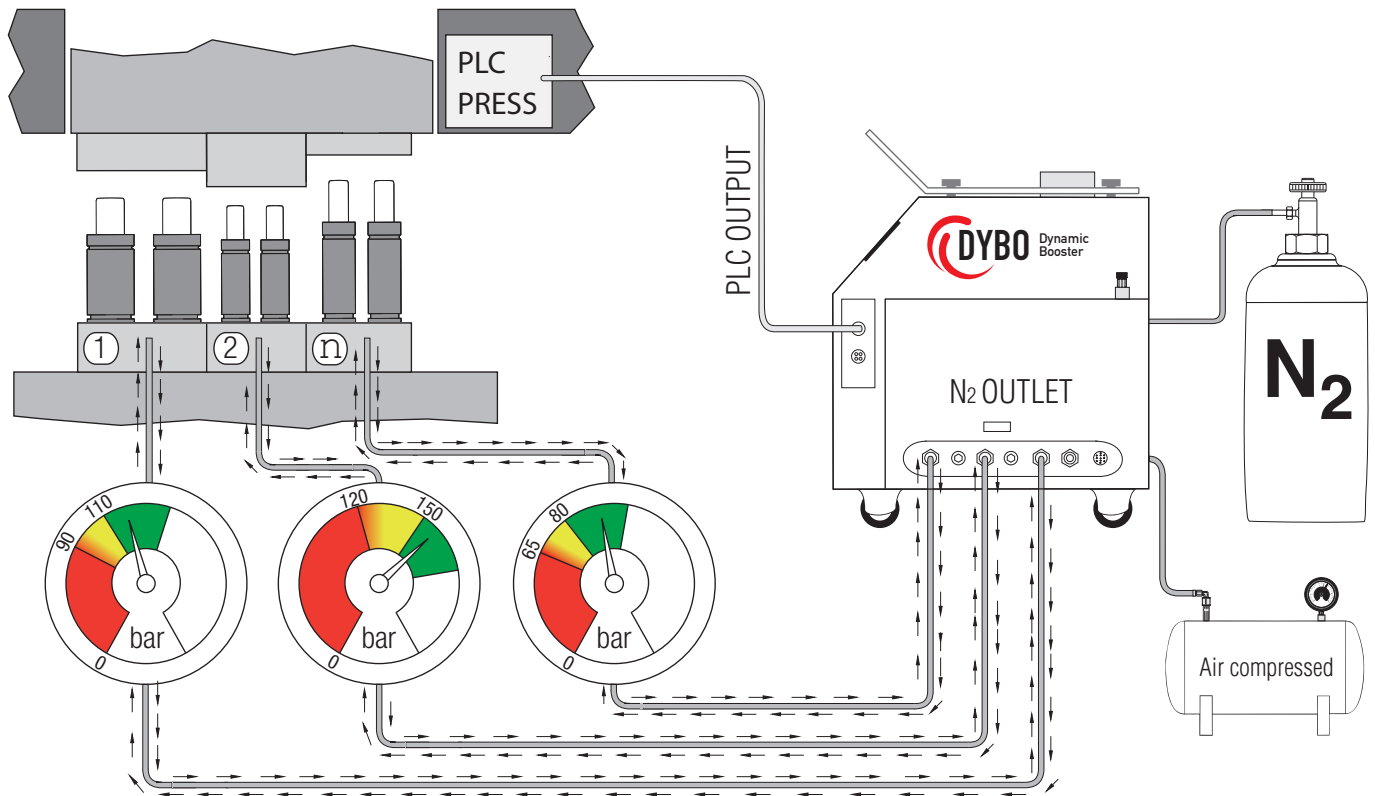

IT Che cosa fa DYBO?

- Controlla e registra in modo continuo il campo di pressione impostato (min - max)
- Controlla e registra in modo continuo il campo di temperatura impostato (min - max)
- Comunica in modo continuo lo stato della pressione nei cilindri
- Ripristina la pressione di lavoro nei cilindri collegati in modo automatico
- Controlla e registra in modo continuo fino a 6 sistemi collegati indipendenti nello stesso stampo

FR Que fait-DYBO?

- Contrôle et enregistre constamment la gamme de pression préprogrammée (min - max)
- Contrôle et enregistre constamment la gamme de températures préprogrammée (min - max)
- Communique constamment les niveaux de pression à la presse
- Réinitialise automatiquement la pression de service dans les ressort à gaz reliés
- Contrôle et enregistre constamment jusqu'à 6 systèmes reliés indépendants dans le même moule

EN What DYBO does?

- Checks and records continuously the set pressure range (min - max)
- Checks and records continuously the set temperature range (min - max)
- Communicates continuously the pressure levels to the press
- Re-sets automatically the working pressure of the linked cylinders
- Checks and records continuously up to 6 independent linked systems

ES ¿Qué hace DYBO?

- Controla y registra continuamente el intervalo de presiones prefijado (min - max)
- Controla y registra continuamente la gama de temperatura prefijada (min - max)
- Comunica continuamente los niveles de presión a la prensa
- Reestablece automáticamente la presión de trabajo en los cilindros de nitrógeno conectados
- Controla y registra continuamente hasta 6 sistemas conectados independientes en el mismo troquel

DE Was macht DYBO?

- Überwacht und speichert kontinuierlich den eingestellten Druckbereich (Min-Max)
- Überwacht und speichert kontinuierlich den eingestellten Temperaturbereich (Min-Max)
- Übermittelt kontinuierlich den Druckstatus an die Presse
- Stellt automatisch den Arbeitsdruck der angeschlossenen Gasdruckfedern nach
- Überwacht und speichert bis zu 6 unabhängige Kreisläufe

PT O que DYBO faz ?

- Controla e registra continuamente a gama de pressões definida (min - max)
- Controla e registra continuamente a gama de temperaturas definida (min - max)
- Comunica continuamente os níveis de pressão ao molde
- Reinicializa automaticamente a pressão de trabalho nos cilindros de nitrogénio interligados
- Controla e registra continuamente até 6 sistemas interligados independentes no mesmo molde

			AIR			
	210 bar <i>3045 psi</i>	30 bar <i>435 psi</i>	6 bar <i>87 psi</i>	0 - 45 °C <i>32 - 113 °F</i>	900 x 850 x 760 mm <i>35 x 33 x 30 inch</i>	158 Kg <i>348 lbs</i>
230/400/415/440/ 480/575 V - 50 Hz / 60Hz						



CYLINDERS WITH CONTROLLED RETURN

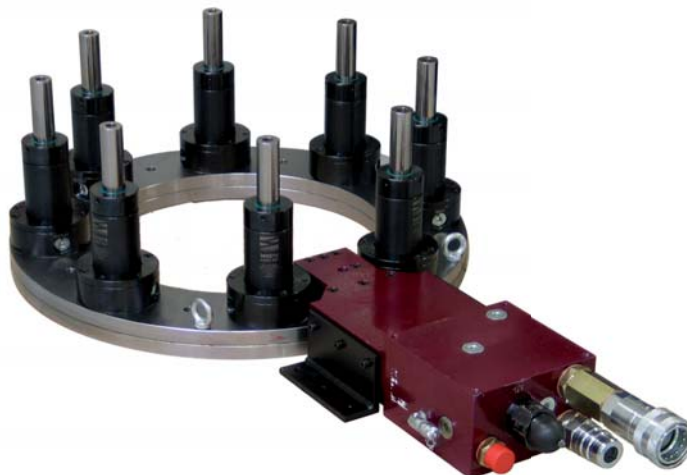

IT VANTAGGI DEL SISTEMA SPECIAL SPRINGS

- Ritorno degli steli dei cilindri indipendente dal ciclo pressa.
- Velocità di ritorno degli steli dei cilindri indipendente dalla velocità della pressa.
- Velocità di ritorno degli steli dei cilindri costante e regolabile.
- Forza di contrasto dei cilindri costante, crescente o decrescente da inizio a fine ciclo di lavoro.
- Utilizzo parziale della corsa dei cilindri possibile senza apportare modifiche al sistema.
- Continuo smaltimento del calore con scambiatori di calore sull'unità di comando.
- Massima affidabilità del sistema garantita dal fluido idraulico continuamente rigenerato.

FR LES AVANTAGES DE SPECIAL SPRINGS SYSTÈME

- Course de retour des pistons indépendante du cycle de la presse.
- Vitesse de remontée des pistons indépendante de la vitesse de la presse.
- Vitesse de remontée des pistons constante et réglable.
- Force d'opposition du vérin : constante, croissante ou décroissante du début à la fin du cycle de travail.
- Utilisation partielle de la course possible sans modification du système.
- Dispersion continue de la chaleur avec un échangeur thermique sur l'unité de commande.
- Fiabilité maximale du système garantie par le renouvellement permanent du fluide hydraulique.

EN ADVANTAGES OF THE SPECIAL SPRINGS SYSTEM

- Return stroke of the cylinder rods independent from press cycle.
- Return speed of cylinder rods independent from press speed.
- Return speed of cylinder rods constant and adjustable.
- Cylinder contrasting force: constant, increasing or decreasing from beginning to end of working cycle.
- Partial use of cylinder stroke possible without system modifications.
- Continuous dispersal of the heat by heat exchanger on the command unit.
- Maximum system reliability guaranteed by the constant renewal of the hydraulic fluid.

ES VENTAJAS DEL SISTEMA SPECIAL SPRINGS

- Retorno del cilindro independiente del ciclo de la prensa.
- Velocidad de retorno del vástago independiente del ciclo de la prensa.
- Velocidad de retorno del vástago constante a regulable.
- Fuerza de contraste del cilindro: constante, aumentable o disminuible de principio a fin del ciclo de trabajo.
- Posibilidad de utilizar incluso parcialmente la carrera sin necesidad de modificar el sistema.
- Continua dispersión del calor con un intercambiador de calor en la unidad de control.
- Fiabilidad máxima del troquel garantizada por la constante renovación del fluido en el sistema.

DE DIE VORTEILE DES SYSTEMS VON SPECIAL SPRINGS

- Rücklauf der Kolbenstangen unabhängig vom Pressenzklus.
- Rücklaufgeschwindigkeit der Kolbenstangen unabhängig von der Pressengeschwindigkeit.
- Rücklaufgeschwindigkeit der Kolbenstangen konstant und einstellbar.
- Gegenkraft der Zylinder konstant, zunehmend oder abnehmend von Anfang bis Ende des Arbeitszyklus.
- Teilnutzung vom Hub der Zylinder möglich, ohne dass dazu Systemänderungen erforderlich sind.
- Kontinuierliche Ableitung der Wärme, durch einen Wärmeaustauscher im Hydraulikaggregat.
- Maximale Zuverlässigkeit des Systems, garantiert durch eine kontinuierliche Filtrierung und Temperierung des Hydrauliköls.

PT VANTAGENS DO SISTEMA SPECIAL SPRINGS

- Curso de retorno do cilindro independente do ciclo da prensa.
- Velocidade de retorno do êmbolo independente do ciclo da prensa.
- Velocidade de retorno do êmbolo constante ou regulável.
- Força do cilindro: constante ou variável (maior ou menor força) do início ao fim do ciclo de trabalho.
- Possibilidade de se usar também parcialmente o curso sem ter necessidade de modificar o sistema.
- Contínua dissipação do calor com um permutador de calor na unidade de comando.
- Máxima fiabilidade da ferramenta garantida pela renovação constante do fluido no sistema.

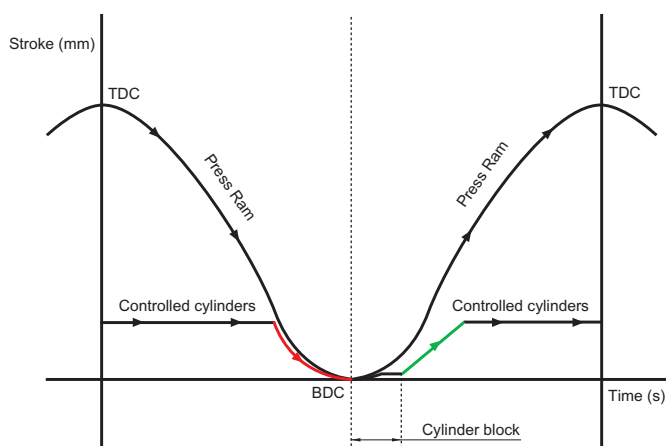

IT Richiedere o scaricare dal sito www.specialsprings.com il catalogo.

EN Ask for or download the catalogue from our web site www.specialsprings.com.

DE Der Katalog von unsere Internetseite www.specialsprings.com heruntergeladen oder anfordern.

FR Demandez ou téléchargez notre catalogue à partir de notre site web www.specialsprings.com.

ES Solicitar o descargar de la web www.specialsprings.com el catálogo.

PT Requerer ou descarregar no site www.specialsprings.com o catálogo.

Questo catalogo annulla e sostituisce i precedenti. Special Springs si riserva il diritto di modificare e di migliorare i suoi prodotti senza alcun preavviso.
This catalog replaces any previous one. Special Springs reserves the right to modify and improve its products without notice.
Dieser Katalog ersetzt alle vorausgegangenen Ausgaben. Die Fa. Special Springs behält sich das Recht vor, Änderungen und Verbesserungen der Produkte ohne Benachrichtigung vorzunehmen.
Ce catalogue remplace et substitue tous les précédentes. Special Springs se réserve le droit de modifier et d'améliorer ses produit sans aucun avis.
Este catálogo cancela y reemplaza los anteriores. Special Springs se reserva el derecho de modificar y añadir nuevos productos sin notificación previa.
Este catalogo anula e substitui o anterior. Special Springs reserva o direito de modificar e melhorar os seus produtos sem aviso prévio.

Headquarter

Special Springs S.r.l.

Via Nardi 124/A

36060 Romano d'Ezzelino (VI) - ITALY

tel. +39 0424 539181 fax +39 0424 898230

info@specialsprings.com - www.specialsprings.com



North America Subsidiary

Special Springs LLC

7707 Ronda Drive, Canton,

Michigan 48187 - USA

Ph. +1 734.892.2324 fax. +1 734.404.5417

info@specialspringsna.com - www.specialspringsna.com

India Subsidiary

Global Special Springs Pvt. Ltd.

Survay no. 69/2 Chandarda Tal. Kadi Dist. Mehesana (Ahmedabad-Mehesana Highway)

Gujarat, 382705 - INDIA

Ph. / fax. +91 2764 273065

info@globalspecialsprings.com - www.specialsprings.com

Catalog code
9800C04600017

